

Service Manual

Digital Camera

LUMIX

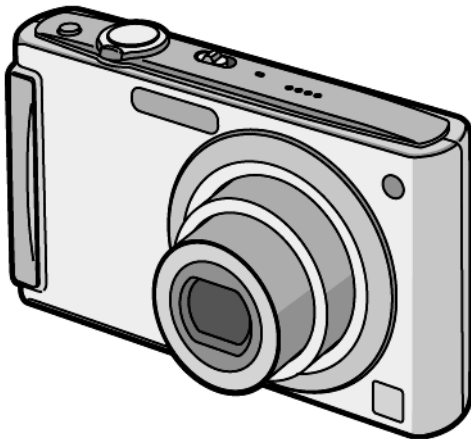

Model No. **DMC-FS3P**
DMC-FS3PC
DMC-FS3PL
DMC-FS3PR
DMC-FS3E
DMC-FS3EB
DMC-FS3EE
DMC-FS3EF
DMC-FS3EG
DMC-FS3GC
DMC-FS3GD
DMC-FS3GK
DMC-FS3GN
DMC-FS3GT
DMC-FS3GJ

Vol. 1

Colour

- (S).....Silver Type (except PR)
- (K).....Black Type (except P/GT)
- (P).....Pink Type (except GD/GK)
- (A).....Blue Type (except GC/GD/GK/GN/GT/GJ)
- (G).....Green Type (only P)

WARNING

This service information is designed for experienced repair technicians only and is not designed for use by the general public. It does not contain warnings or cautions to advise non-technical individuals of potential dangers in attempting to service a product. Products powered by electricity should be serviced or repaired only by experienced professional technicians. Any attempt to service or repair the product or products dealt with in this service information by anyone else could result in serious injury or death.

Panasonic[®]

© 2008 Matsushita Electric Industrial Co., Ltd. All rights reserved. Unauthorized copying and distribution is a violation of law.

TABLE OF CONTENTS

	PAGE	PAGE
1 Safety Precaution	3	
1.1. General Guidelines	3	
1.2. Leakage Current Cold Check	3	
1.3. Leakage Current Hot Check (See Figure 1.)	3	
1.4. How to Discharge the Capacitor on Flash Top PCB	4	
2 Warning	5	
2.1. Prevention of Electrostatic Discharge (ESD) to Electrostatically Sensitive (ES) Devices	5	
2.2. How to Recycle the Lithium Ion Battery (U.S. Only)	5	
2.3. Caution for AC Cord(For EB/GC/SG)	6	
2.4. How to Replace the Lithium Battery	7	
3 Service Navigation	8	
3.1. Introduction	8	
3.2. General Description About Lead Free Solder (PbF)	8	
3.3. Important Notice 1:(Other than U.S.A. and Canadian Market)	8	
3.4. How to Define the Model Suffix (NTSC or PAL model)	9	
4 Specifications	12	
5 Location of Controls and Components	13	
6 Service Mode	15	
6.1. Error Code Memory Function	15	
7 Service Fixture & Tools	18	
7.1. Service Fixture and Tools	18	
7.2. When Replacing the Main PCB	19	
7.3. Service Position	19	
8 Disassembly and Assembly Instructions	20	
8.1. Disassembly Flow Chart	20	
8.2. PCB Location	20	
8.3. Disassembly Procedure	21	
8.4. Disassembly Procedure for the Lens	26	
8.5. Assembly Procedure for the Lens	28	
8.6. Removal of the CCD Unit	30	
8.7. Removal of the Focus Motor Unit	31	
8.8. The Applymt of Grease Method	31	
9 Measurements and Adjustments	32	
9.1. Matrix Chart for Replaced Part and Necessary Adjustment	32	
10 Maintenance	33	
10.1. Cleaning Lens and LCD Panel	33	

1 Safety Precaution

1.1. General Guidelines

1. IMPORTANT SAFETY NOTICE

There are special components used in this equipment which are important for safety. These parts are marked by

 in the Schematic Diagrams, Circuit Board Layout, Exploded Views and Replacement Parts List. It is essential that these critical parts should be replaced with manufacturer's specified parts to prevent X-RADIATION, shock, fire, or other hazards. Do not modify the original design without permission of manufacturer.

2. An Isolation Transformer should always be used during the servicing of AC Adaptor whose chassis is not isolated from the AC power line. Use a transformer of adequate power rating as this protects the technician from accidents resulting in personal injury from electrical shocks. It will also protect AC Adaptor from being damaged by accidental shorting that may occur during servicing.
3. When servicing, observe the original lead dress. If a short circuit is found, replace all parts which have been overheated or damaged by the short circuit.
4. After servicing, see to it that all the protective devices such as insulation barriers, insulation papers shields are properly installed.
5. After servicing, make the following leakage current checks to prevent the customer from being exposed to shock hazards.

1.2. Leakage Current Cold Check

1. Unplug the AC cord and connect a jumper between the two prongs on the plug.
2. Measure the resistance value, with an ohmmeter, between the jumpered AC plug and each exposed metallic cabinet part on the equipment such as screwheads, connectors, control shafts, etc. When the exposed metallic part has a return path to the chassis, the reading should be between $1\text{ M}\Omega$ and $5.2\text{ M}\Omega$. When the exposed metal does not have a return path to the chassis, the reading must be infinity.

1.3. Leakage Current Hot Check (See Figure 1.)

1. Plug the AC cord directly into the AC outlet. Do not use an isolation transformer for this check.
2. Connect a $1.5\text{ k}\Omega$, 10 W resistor, in parallel with a $0.15\text{ }\mu\text{F}$ capacitor, between each exposed metallic part on the set and a good earth ground, as shown in Figure 1.
3. Use an AC voltmeter, with $1\text{ k}\Omega/\text{V}$ or more sensitivity, to measure the potential across the resistor.
4. Check each exposed metallic part, and measure the voltage at each point.
5. Reverse the AC plug in the AC outlet and repeat each of the above measurements.
6. The potential at any point should not exceed 0.75 V RMS . A leakage current tester (Simpson Model 229 or equivalent) may be used to make the hot checks, leakage current must not exceed $1/2\text{ mA}$. In case a measurement is outside of the limits specified, there is a possibility of a shock hazard, and the equipment should be repaired and rechecked before it is returned to the customer.

Hot-Check Circuit

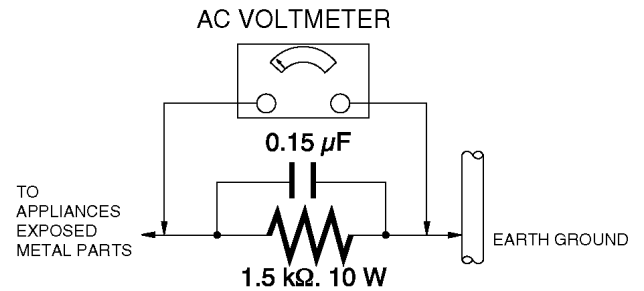

Figure. 1

1.4. How to Discharge the Capacitor on Flash Top PCB

CAUTION:

1. Be sure to discharge the capacitor on FLASH TOP PCB.
2. Be careful of the high voltage circuit on FLASH TOP PCB when servicing.

[Discharging Procedure]

1. Refer to the disassemble procedure and Remove the necessary parts/unit.
2. Put the insulation tube onto the lead part of Resistor (ERG5SJ102:1k Ω /5W).
(an equivalent type of resistor may be used.)
3. Put the resistor between both terminals of capacitor on FLASH TOP PCB for approx. 5 seconds.
4. After discharging confirm that the capacitor voltage is lower than 10V using a voltmeter.

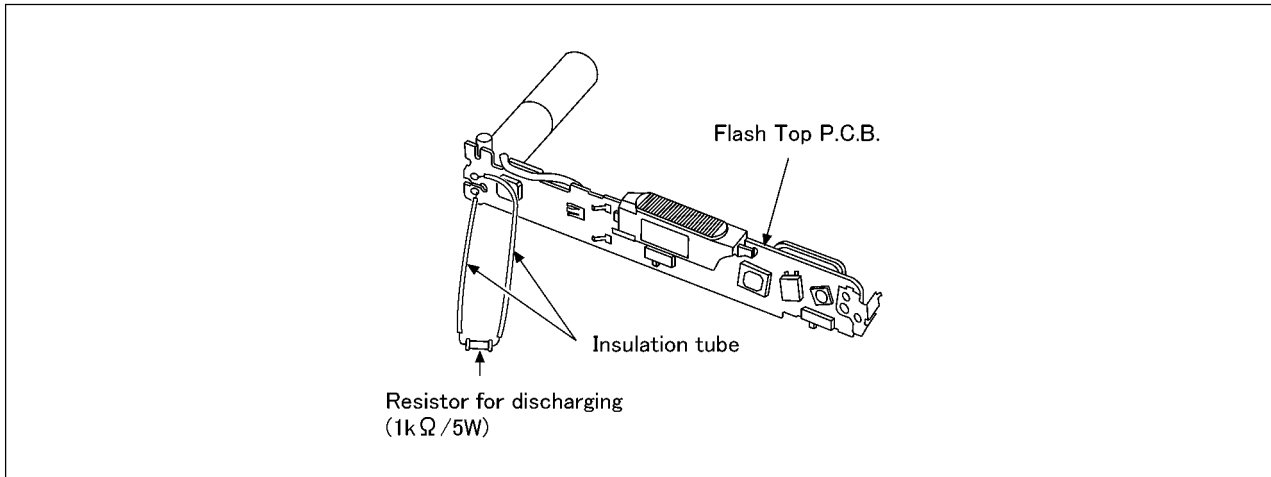

Fig. F1

2 Warning

2.1. Prevention of Electrostatic Discharge (ESD) to Electrostatically Sensitive (ES) Devices

Some semiconductor (solid state) devices can be damaged easily by static electricity. Such components commonly are called Electrostatically Sensitive (ES) Devices.

Examples of typical ES devices are CCD image sensor, IC (integrated circuits) and some field-effect transistors and semiconductor "chip" components.

The following techniques should be used to help reduce the incidence of component damage caused by electrostatic discharge (ESD).

1. Immediately before handling any semiconductor component or semiconductor-equipped assembly, drain off any ESD on your body by touching a known earth ground. Alternatively, obtain and wear a commercially available discharging ESD wrist strap, which should be removed for potential shock reasons prior to applying power to the unit under test.
2. After removing an electrical assembly equipped with ES devices, place the assembly on a conductive surface such as aluminum foil, to prevent electrostatic charge buildup or exposure of the assembly.
3. Use only a grounded-tip soldering iron to solder or unsolder ES devices.
4. Use only an antistatic solder removal device. Some solder removal devices not classified as "antistatic (ESD protected)" can generate electrical charge sufficient to damage ES devices.
5. Do not use freon-propelled chemicals. These can generate electrical charges sufficient to damage ES devices.
6. Do not remove a replacement ES device from its protective package until immediately before you are ready to install it. (Most replacement ES devices are packaged with leads electrically shorted together by conductive foam, aluminum foil or comparable conductive material).
7. Immediately before removing the protective material from the leads of a replacement ES device, touch the protective material to the chassis or circuit assembly into which the device will be installed.

CAUTION :

Be sure no power is applied to the chassis or circuit, and observe all other safety precautions.

8. Minimize bodily motions when handling unpackaged replacement ES devices. (Otherwise harmless motion such as the brushing together of your clothes fabric or the lifting of your foot from a carpeted floor can generate static electricity (ESD) sufficient to damage an ES device).

2.2. How to Recycle the Lithium Ion Battery (U.S. Only)

ENGLISH



A lithium ion battery that is recyclable powers the product you have purchased. Please call 1-800-8-BATTERY for information on how to recycle this battery.

FRANÇAIS



L'appareil que vous vous êtes procuré est alimenté par une batterie au lithium-ion recyclable. Pour des renseignements sur le recyclage de la batterie, veuillez composer le 1-800-8-BATTERY.

2.3. Caution for AC Cord (For EB/GC)

2.3.1. Information for Your Safety

IMPORTANT

Your attention is drawn to the fact that recording of pre-recorded tapes or discs or other published or broadcast material may infringe copyright laws.

WARNING

To reduce the risk of fire or shock hazard, do not expose this equipment to rain or moisture.

CAUTION

To reduce the risk of fire or shock hazard and annoying interference, use the recommended accessories only.

FOR YOUR SAFETY

DO NOT REMOVE THE OUTER COVER

To prevent electric shock, do not remove the cover. No user serviceable parts inside. Refer servicing to qualified service personnel.

2.3.2. Caution for AC Mains Lead

For your safety, please read the following text carefully.

This appliance is supplied with a moulded three-pin mains plug for your safety and convenience.

A 5-ampere fuse is fitted in this plug.

Should the fuse need to be replaced please ensure that the replacement fuse has a rating of 5 amperes and it is approved by ASTA or BSI to BS1362

Check for the ASRA mark or the BSI mark on the body of the fuse.



If the plug contains a removable fuse cover you must ensure that it is refitted when the fuse is replaced.

If you lose the fuse cover, the plug must not be used until a replacement cover is obtained.

A replacement fuse cover can be purchased from your local Panasonic Dealer.

If the fitted moulded plug is unsuitable for the socket outlet in your home then the fuse should be removed and the plug cut off and disposed of safely.

There is a danger of severe electrical shock if the cut off plug is inserted into any 13-ampere socket.

If a new plug is to be fitted please observe the wiring code as shown below.

If in any doubt, please consult a qualified electrician.

2.3.2.1. Important

The wires in this mains lead are coloured in accordance with the following code:

Blue	Neutral
Brown	Live

As the colours of the wires in the mains lead of this appliance may not correspond with the coloured markings identifying the terminals in your plug, proceed as follows:

The wire which is coloured BLUE must be connected to the terminal in the plug which is marked with the letter N or coloured BLACK.

The wire which is coloured BROWN must be connected to the terminal in the plug which is marked with the letter L or coloured RED.

Under no circumstances should either of these wires be connected to the earth terminal of the three pin plug, marked with the letter E or the Earth Symbol.



2.3.2.2. Before Use

Remove the Connector Cover as follows.

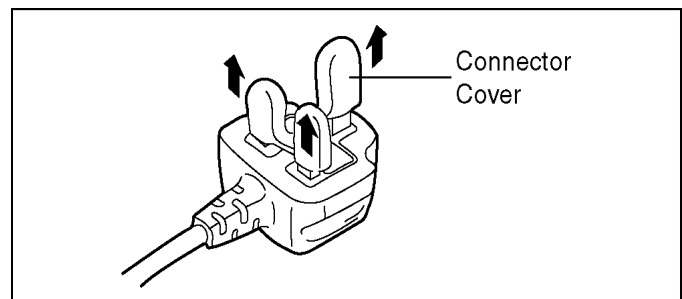

2.3.2.3. How to Replace the Fuse

1. Remove the Fuse Cover with a screwdriver.

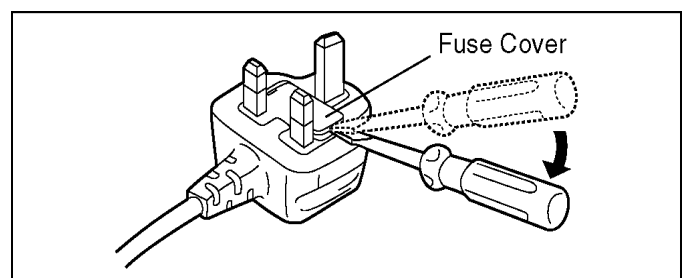

2. Replace the fuse and attach the Fuse cover.

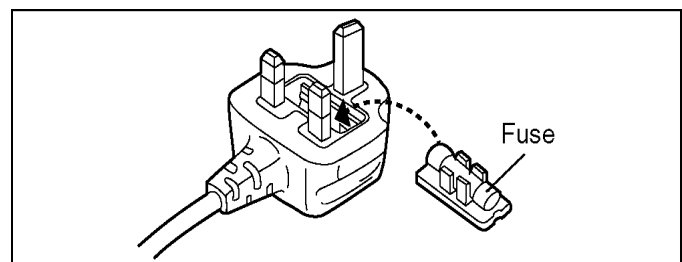

2.4. How to Replace the Lithium Battery

2.4.1. Replacement Procedure

1. Remove the MAIN PCB. (Refer to Disassembly Procedures.)
2. Remove the Lithium battery (Ref. No. "B9101" at foil side of MAIN PCB) and then replace it into new one.

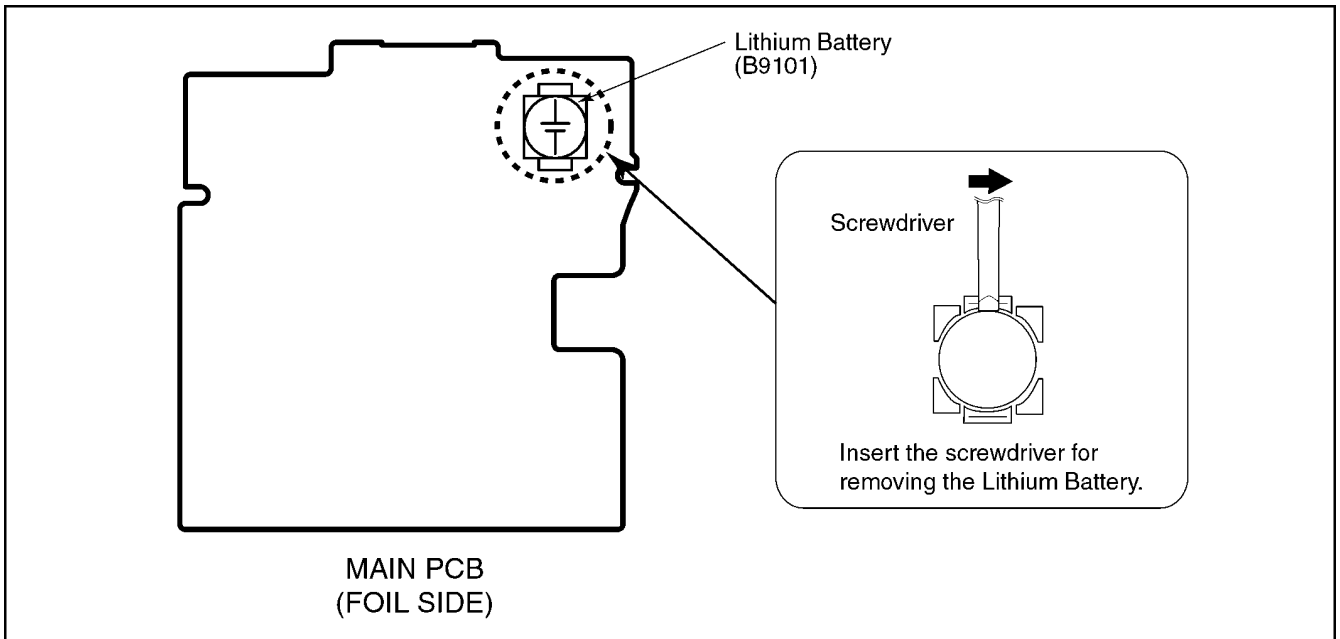

NOTE:

This Lithium battery is a critical component.

(Type No.: ML421S/ZTE **Manufactured by Matsushita Battery Industrial Co.,Ltd.**)

It must never be subjected to excessive heat or discharge.

It must therefore only be fitted in requirement designed specifically for its use.

Replacement batteries must be of same type and manufacture.

They must be fitted in the same manner and location as the original battery, with the correct polarity contacts observed.

Do not attempt to re-charge the old battery or re-use it for any other purpose.

It should be disposed of in waste products destined for burial rather than incineration.

(For English)

CAUTION

Danger of explosion if battery is incorrectly replaced.

Replace only with the same or equivalent type recommended by the manufacturer.

Dispose of used batteries according to the manufacturer's instructions.

(For German)

ACHTUNG

Explosionsgefahr bei falschem Anbringen der Batterie. Ersetzen Sie nur mit einem äquivalentem vom Hersteller empfohlenem Typ.

Behandeln Sie gebrauchte Batterien nach den Anweisungen des Herstellers.

(For French)

MISE EN GARDE

Une batterie de remplacement inappropriée peut exploser. Ne remplacez qu'avec une batterie identique ou d'un type recommandé par le fabricant. L'élimination des batteries usées doit être faite conformément aux instructions du manufacturier.

NOTE:

Above caution is applicable for a battery pack which is for DMC-FS3 series, as well.

3 Service Navigation

3.1. Introduction

This service manual contains technical information, which allow service personnel's to understand and service this model.

Please place orders using the parts list and not the drawing reference numbers.

If the circuit is changed or modified, the information will be followed by service manual to be controlled with original service manual.

3.2. General Description About Lead Free Solder (PbF)

The lead free solder has been used in the mounting process of all electrical components on the printed circuit boards used for this equipment in considering the globally environmental conservation.

The normal solder is the alloy of tin (Sn) and lead (Pb). On the other hand, the lead free solder is the alloy mainly consists of tin (Sn), silver (Ag) and Copper (Cu), and the melting point of the lead free solder is higher approx.30°C (86°F) more than that of the normal solder.

Distinction of PCB Lead Free Solder being used

The letter of "PbF" is printed either foil side or components side on the PCB using the lead free solder.(See right figure)

PbF

Service caution for repair work using Lead Free Solder (PbF)

- The lead free solder has to be used when repairing the equipment for which the lead free solder is used.
(Definition: The letter of "PbF" is printed on the PCB using the lead free solder.)
- To put lead free solder, it should be well molten and mixed with the original lead free solder.
- Remove the remaining lead free solder on the PCB cleanly for soldering of the new IC.
- Since the melting point of the lead free solder is higher than that of the normal lead solder, it takes the longer time to melt the lead free solder.
- Use the soldering iron (more than 70W) equipped with the temperature control after setting the temperature at 350±30°C (662±86°F).

Recommended Lead Free Solder (Service Parts Route.)

- The following 3 types of lead free solder are available through the service parts route.
 - RFKZ03D01K----- (0.3mm 100g Reel)
 - RFKZ06D01K----- (0.6mm 100g Reel)
 - RFKZ10D01K----- (1.0mm 100g Reel)

Note

* Ingredient: tin (Sn) 96.5%, silver (Ag) 3.0%, Copper (Cu) 0.5%, Cobalt (Co) / Germanium (Ge) 0.1 to 0.3%

3.3. Important Notice 1:(Other than U.S.A. and Canadian Market)

1. The service manual does not contain the following information, because of the impossibility of servicing at component level without concerned equipment/facilities.
 - a. Schematic diagram, Block Diagram and PCB layout of MAIN PCB.
 - b. Parts list for individual parts for MAIN PCB.When a part replacement is required for repairing MAIN PCB, replace as an assembled parts. (Main PCB)
2. The following category is/are recycle module part. please send it/them to Central Repair Center.
 - MAIN PCB (VEP56057B): Excluding replacement of Lithium Battery

3.4. How to Define the Model Suffix (NTSC or PAL model)







There are seven kinds of DMC-FS3, regardless of the colours.

- a) DMC-FS3 (Japan domestic model)
- b) DMC-FS3P/PC
- c) DMC-FS3E/EB/EF/EG/GN
- d) DMC-FS3EE
- e) DMC-FS3GD
- f) DMC-FS3GT/GK
- g) DMC-FS3PL/GC/PR/GJ

What is the difference is that the "INITIAL SETTINGS" data which is stored in Flash ROM mounted on Main PCB.

3.4.1. Defining methods:

To define the model suffix to be serviced, refer to the nameplate which is putted on the bottom side of the Unit.

<p>a) DMC-FS3 (Japan domestic model) The nameplate for this model show the following Safety registration mark.</p> 	
<p>b) DMC-FS3P/PC The nameplate for these models show the following Safety registration mark.</p> 	
<p>c) DMC-FS3E/EB/EF/EG/GN The nameplate for these models show the following Safety registration mark.</p> 	
<p>d) DMC-FS3EE The nameplate for this model show the following Safety registration mark.</p> 	
<p>d) DMC-FS3GD The nameplate for this model show the following Safety registration mark.</p> 	
<p>e) DMC-FS3GT/GK The nameplate for these models show full model number. (with suffix)</p>	
<p>f) DMC-FS3PL/GC/PR/GJ The nameplate for these models do not show any above Safety registration marks.</p>	

NOTE:

After replacing the MAIN PCB, be sure to achieve adjustment.

The adjustment instruction is available at "software download" on the "Support Information from NWBG/VDBG-PAVC" web-site in "TSN system", together with Maintenance software.

3.4.2. INITIAL SETTINGS:

When you replace the Main PCB, be sure to perform the initial settings after achieving the adjustment by ordering the following procedure in accordance with model suffix of the unit.

1. IMPORTANT NOTICE:

Before proceeding Initial settings, be sure to read the following CAUTIONS.

CAUTION 1 (Initial Settings)

DO NOT select "NONE(JAPAN)" or "P"(North America) if need to select "EG/E/PL/PR/GD/GC/GT/GK/GJ/EF/EB/EE/GN and PC".
 Otherwise, once "NONE(JAPAN)" or "P"(North America) are selected, "EG/E/PL/PR/GD/GC/GT/GK/GJ/EF/EB/EE/GN and PC" will not displayed, thus, RE-Settings (changing area) can not be made.

CAUTION 2 (Picture back up from "Built-in Memory")

This unit employs "Built-in Memory" for picture image data recording.(Approx. 50MB)
 Be sure to make picture data back up (i.e., Copying to SD memory card), before proceeding "INITIAL SETTINGS".
 Once "INITIAL SETTINGS" has been carried out, all image data stored at "Built-in Memory" is erased.

2. PROCEDURES:

- Precautions: Proceed the picture back up from the unit. (Refer to above "CAUTION 2")
- Preparation. Set the Recording mode to "Normal Picture Mode".
 Set the [REC]/[PLAYBACK] selector switch to "[REC] (Red camera mark)".
 Turn on the power and then press the [MODE] button.
 Select the "NORMAL PICTURE MODE" using "[UP] / [DOWN] of Cursor button".
 Press [MENU/SET] button, then turn the power off.
- **Step 1. The temporary cancellation of initial setting:**
 Set the [REC]/[PLAYBACK] selector switch to "[REC] (Red camera mark)".
 While keep pressing [E.ZOOM] and "[UP] of Cursor buttons" simultaneously, turn the Power on.
- **Step 2. The cancellation of initial setting:**
 Set the [REC]/[PLAYBACK] selector switch to "[PLYBACK]".
 Press [E.ZOOM] and "[UP] of Cursor buttons" simultaneously, then turn the Power off.
- **Step 3. Turn the Power on:**
 Set the [REC]/[PLAYBACK] selector switch to "[REC] (Red camera mark)", and then turn the Power on.
- **Step 4. Display the INITIAL SETTING:**
 While keep pressing [MENU] and "[RIGHT] of Cursor buttons" simultaneously, turn the Power off.

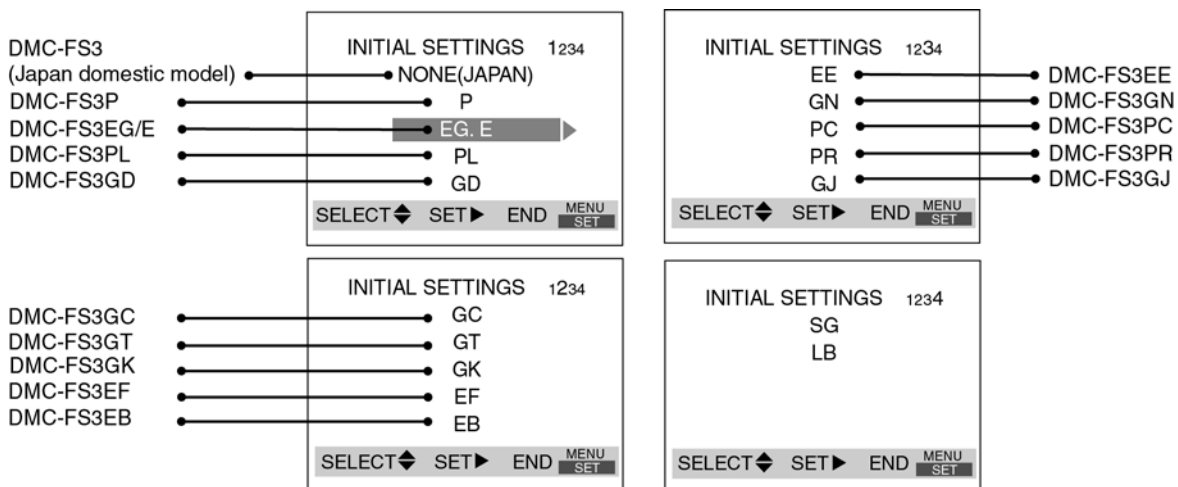

• **Step 5. Set the INITIAL SETTING: (Refer to “CAUTION 1”)**

[Caution for before settings]

Once "NONE(JAPAN)" (Area for Japan) or "P" (Area for North America) is selected with "INITIAL SETTINGS", other areas will not be displayed even if "INITIAL SETTINGS" menu is displayed again, thus, the area can not be changed.

Select the area carefully.

Select the area with pressing “[UP] / [DOWN] of Cursor buttons”, and then press the “[RIGHT] of Cursor buttons”.

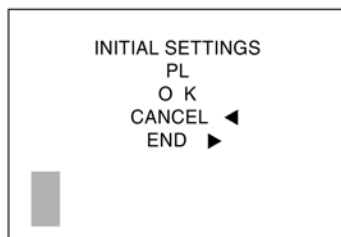

The only set area is displayed, and then press the “[RIGHT] of Cursor buttons” after confirmation.

(The unit is powered off automatically.)

Confirm the display of “PLEASE SET THE CLOCK” in English when the unit is turned on again.

• **Step 6. CONFIRMATION:**

The display shows “PLEASE SET THE CLOCK” when turn the Power on again.

When the unit is connected to PC with USB cable, it is detected as removable media.

(When the “GT” or “GK” model suffix is selected, the display shows “PLEASE SET THE CLOCK” in Chinese.)

1) As for your reference Default setting condition is given in the following table.

• **Default setting (After “INITIAL SETTINGS”)**

	MODEL	VIDEO OUTPUT	LANGUAGE	DATE	REMARKS
a)	DMC-FS3 (Japan domestic model)	NTSC	Japanese	Year/Month/Date	
b)	DMC-FS3P/PC/PL	NTSC	English	Month/Date/Year	
c)	DMC-FS3E/EB/EG/GC/GN/PR	PAL	English	Date/Month/Year	
d)	DMC-FS3EF	PAL	French	Date/Month/Year	
e)	DMC-FS3EE	PAL	Russian	Date/Month/Year	
f)	DMC-FS3GK	PAL	Chinese (simplified)	Year/Month/Date	
g)	DMC-FS3GT	NTSC	Chinese (traditional)	Year/Month/Date	
h)	DMC-FS3GD	NTSC	Korean	Year/Month/Date	
i)	DMC-FS3GJ	PAL	Thai	Date/Month/Year	

4 Specifications

Digital Camera: Information for your safety

Power Source:	DC 5.1 V
Power Consumption:	1.3 W (When recording) 0.8 W (When playing back)

Camera effective pixels: 8,100,000 pixels
Image sensor: 1/2.5" CCD, total pixel number 8,320,000 pixels, Primary color filter
Lens: Optical 3× zoom, f= 5.5 mm to 16.5 mm (35 mm film camera equivalent: 33 mm to 100 mm)/F2.8 to F5.1
Digital zoom: Max. 4 ×
Extended optical zoom: Max. 4.8 ×
Focus: Normal/Macro/Face detection/9-area-focusing/1-area-focusing (High speed)/1-area-focusing
Focus range: Normal: 50 cm (1.64 feet) to ∞
 Macro/Intelligent auto: 5 cm (0.17 feet) (Wide)/30 cm (0.99 feet) (Tele) to ∞
 Scene mode: There may be differences in the above settings.
Shutter system: Electronic shutter+Mechanical shutter
Motion picture recording: When the aspect ratio setting is [4:3] 640×480 pixels (30 frames/second, 10 frames/second, only when using a Card)
 320×240 pixels (30 frames/second, 10 frame/second)
 When the aspect ratio setting is [16:9] 848×480 pixels (30 frames/second, 10 frames/second, only when using a Card)
Burst recording
Burst speed: 3 pictures/second (Normal), Approx. 2 pictures/second (Unlimited)
Number of recordable pictures: 7 pictures (Standard), 4 pictures (Fine), Depends on the remaining capacity of the built-in memory or the card (Unlimited). (Performance in burst recording is only with SD Memory Card/SDHC Memory Card. MultiMediaCard performance will be less.)
Hi-speed burst
Burst speed: Approx. 7 pictures/second (2M (4:3), 2.5M (3:2) or 2M (16:9) is selected as the picture size.)
Number of recordable pictures: When using the built-in memory: Approx. 15 pictures (immediately after formatting)
 When using a Card: Max. 100 pictures (differs depending on the type of Card and the recording conditions)
ISO sensitivity: AUTO/100/200/400/800/1600 [HIGH SENS.] mode: 1600 to 6400
Shutter speed: 8 seconds to 1/2000th of a second [STARRY SKY] mode: 15 seconds, 30 seconds, 60 seconds
White balance: Auto white balance/Daylight/Cloudy/Shade/Halogen/White set
Exposure (AE): program AE Exposure compensation (1/3 EV Step, - 2 EV to + 2 EV)
Metering mode: Multiple
LCD monitor: 2.5" TFT LCD (Approx. 230,000 dots) (field of view ratio about 100%)
Flash: Flash range: [ISO AUTO] Approx. 30 cm (0.99 feet) to 6.3 m (20.7 feet) (Wide) AUTO, AUTO/Red-eye reduction, Forced ON (Forced ON/Red-eye reduction), Forced OFF (, Slow sync./Red-eye reduction)

Microphone: Monaural
Speaker: Monaural
Recording media: Built-in Memory (Approx. 50 MB)/SD Memory Card/SDHC Memory Card/MultiMediaCard (Still pictures only)
Picture size
Still picture: When the aspect ratio setting is [4:3] 3264×2448 pixels, 2560×1920 pixels, 2048×1536 pixels, 1600×1200 pixels, 640×480 pixels
 When the aspect ratio setting is [3:2] 3264×2176 pixels, 2560×1712 pixels, 2048×1360 pixels
 When the aspect ratio setting is [16:9] 3264×1840 pixels, 2560×1440 pixels, 1920×1080 pixels
Motion pictures: When the aspect ratio setting is [4:3] 640×480 pixels (Only when using a Card), 320×240 pixels
 When the aspect ratio setting is [16:9] 848×480 pixels (Only when using a Card)
 Fine/Standard
Quality:
Recording file format
Still Picture: JPEG (based on Design rule for Camera File system, based on Exif 2.21 standard)/DPOF corresponding QuickTime Motion JPEG (motion pictures with audio)
Motion pictures:
Interface
Digital: USB 2.0 (Full Speed)
Analog video/audio: NTSC/PAL Composite (Switched by menu), Audio line output (monaural)
Terminal
[AV OUT/DIGITAL]: Dedicated jack (8 pin)
[DC IN]: Dedicated jack (2 pin)
Dimensions: Approx. 94.9 mm (W)×53.4 mm (H)×22.5 mm (D) [3 3/4" (W)×2 1/8" (H)×7/8" (D)] (excluding the projecting parts)
Mass (weight): Approx. 118 g/4.16 oz (excluding card and battery), Approx. 140 g/4.94 oz (with card and battery)
Operating temperature: 0 °C to 40 °C (32 °F to 104 °F)
Operating humidity: 10% to 80%

Battery Charger
(Panasonic DE-A39B): Information for your safety

Input:	110 V to 240 V ~ 50/60 Hz, 0.2 A
Output:	CHARGE 4.2 V --- 0.8 A

Equipment mobility: Movable

Battery Pack
(Lithium-ion)
(Panasonic DMW-BCE10PP): Information for your safety

Voltage/capacity:	3.6 V, 1000 mAh
--------------------------	-----------------

5 Location of Controls and Components

Names of the Components

- 1 Flash
- 2 Lens
- 3 Self-timer indicator
AF assist lamp

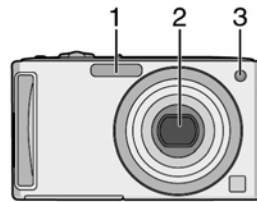

- 4 LCD monitor
- 5 Status indicator
- 6 [MENU/SET] button
- 7 [DISPLAY] button
- 8 [Q.MENU]/Delete button
- 9 [MODE] button
- 10 [REC]/[PLAYBACK] selector switch

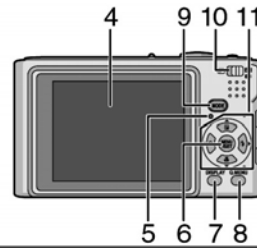

- 11 Cursor buttons
 - Ⓐ: ▲/Exposure compensation /
Auto bracket/The Backlight
Compensation
 - Ⓑ: ▼/Macro mode
 - Ⓒ: ◀/Self-timer button
 - Ⓓ: ▶/Flash setting button

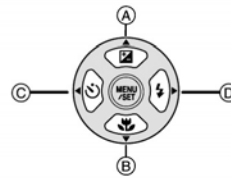

- 12 Camera ON/OFF switch
- 13 Zoom lever
- 14 Speaker
- 15 Microphone
- 16 Shutter button
- 17 [E.ZOOM] button

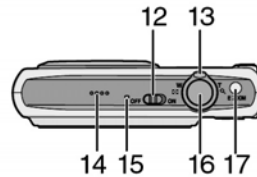

- 18 Strap eyelet
 - Be sure to attach the strap when using the camera to ensure that you will not drop it.
- 19 Lens barrel
- 20 [AV OUT/DIGITAL] socket
- 21 [DC IN] socket
 - Always use a genuine Panasonic AC adaptor (DMW-AC5PP; optional).
 - This camera cannot charge the battery even when the AC adaptor (DMW-AC5PP; optional) is connected to it.

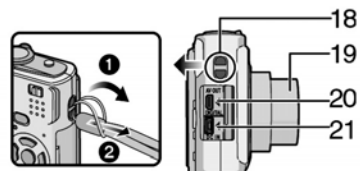

- 22 Tripod receptacle
 - When you use a tripod, make sure the tripod is stable when the camera is attached to it.
- 23 Card/Battery door
- 24 Release lever

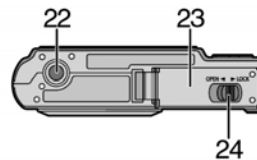

Selecting the [REC] Mode

When the [REC] mode is selected, the camera can be set to the Intelligent auto mode in which the optimal settings are established in line with the subject to be recorded and the recording conditions, or to the scene mode which enables you to take pictures that match the scene being recorded.

1 Turn the camera on.

- A [MENU/SET] button
- B [REC]/[PLAYBACK] selector switch
- C [MODE] button

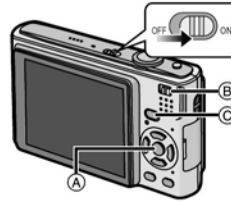

2 Slide the [REC]/[PLAYBACK] selector switch to [iA/📷].

3 Press [MODE].

4 Press ▲/▼ to select the mode.

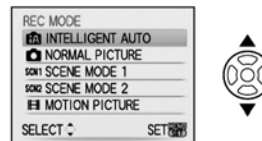

5 Press [MENU/SET].

■ List of [REC] modes

[iA] Intelligent auto mode

The subjects are recorded using settings automatically selected by the camera.

📷 Normal picture mode

The subjects are recorded using your own settings.

SCN1 Scene mode1/Scene mode2 SCN2

This allows you to take pictures that match the scene being recorded.

[M] Motion picture mode

This mode allows you to record motion pictures with audio.

Note

- When the mode has been switched from [PLAYBACK] mode to [REC] mode, the previously set [REC] mode will be set.

6 Service Mode

6.1. Error Code Memory Function

1. General description

This unit is equipped with history of error code memory function, and can be memorized 16 error codes in sequence from the latest. When the error is occurred more than 16, the oldest error is overwritten in sequence.

The error code is not memorized when the power supply is shut down forcibly (when the unit is powered on by the battery, the battery is pulled out) because the error code is memorized to FLASH ROM when the unit is powered off.

2. How to display

The error code can be displayed by the following procedure:

Before perform the error code memory function, connect the AC adaptor or insert the battery.

(Since this unit has built-in memory, this error code memory function can be performed without inserting SD memory card.)

- **1. The temporary cancellation of initial setting:**

Set the [REC]/[PLAYBACK] selector switch to “[REC] (Red camera mark)”.

While keep pressing [E.ZOOM] and “[UP] of Cursor buttons” simultaneously, turn the Power on.

- **2. The display of error code:**

Press [E.ZOOM], [MENU] and “[LEFT] of Cursor buttons” simultaneously with the step 1 condition.

The display is changed as shown below when the above buttons is pressed simultaneously.

Normal display → Error code display → Operation history display → Normal display →

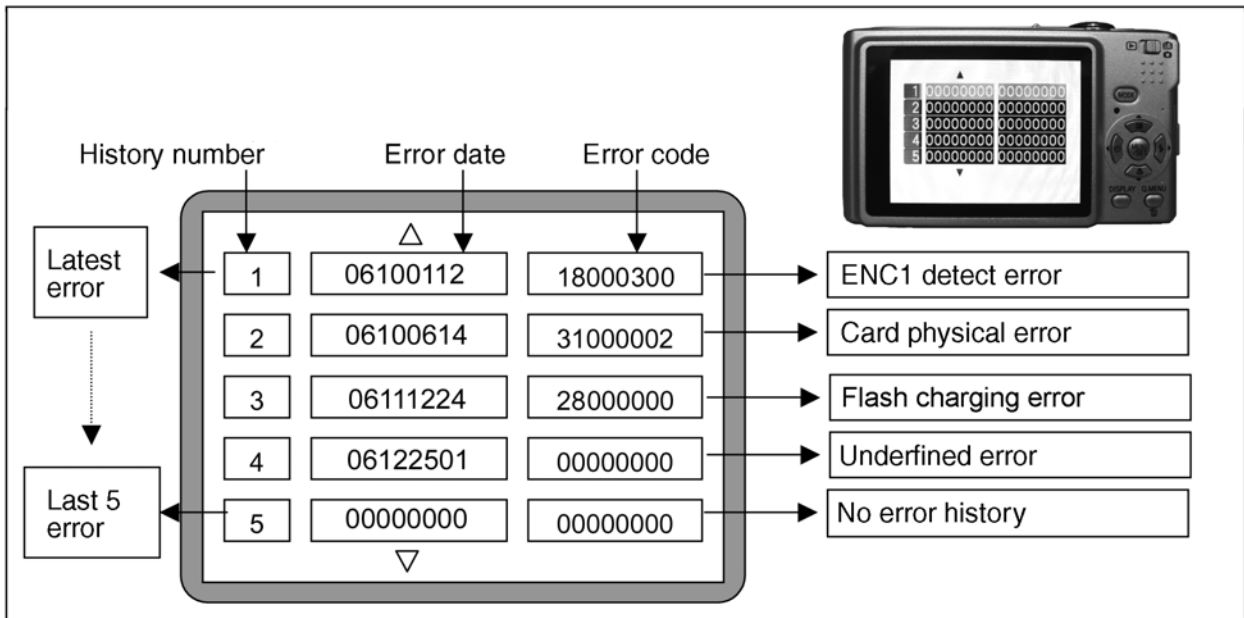

Example of Error Code Display

- **3. The change of display:**

The error code can be memorized 16 error codes in sequence, however it is displayed 5 errors on the LCD.

Display can be changed by the following procedure:

“[UP] or [DOWN] of Cursor buttons” : It can be scroll up or down one.

“[LEFT] or [RIGHT] of Cursor buttons” : It can be display last 5 error or another 5 error.

- **4. How to read the error date:**

The error date code is displayed from the left in order at the year, month, day, time.

Error date information is acquired from "Clock setting" information when the error occurs. When the clock is not setting, it is displayed as "00000000".

• 5. How to read the error code:

One error code is displayed for 8 bit, the contents of error codes is indicated the table as shown below.

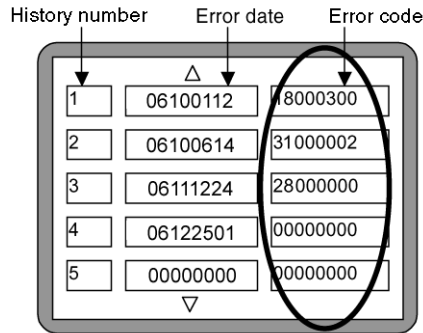

Attribute	Main item	Sub item	Error code		Contents (Upper)
			High 4 bits	Low 4 bits	Check point (Lower)
LENS	Lens drive	OIS	18*0	1000	PSD (X) error. Hall element (X axis) position detect error in OIS unit. OIS Unit
				2000	PSD (Y) error. Hall element (Y axis) position detect error in OIS unit. OIS Unit
				3000	GYRO (X) error. Gyro (IC7101: X axis) detect error on Main P.C.B.. IC7101 (Gyro element) or IC6001 (VENUS 4)
				4000	GYRO (Y) error. Gyro (IC7101: Y axis) detect error on Main P.C.B.. IC7101 (Gyro element) or IC6001 (VENUS 4)
				5000	MREF error (Reference voltage error). IC9101 (LENS drive) or IC6001 (VENUS 4)
				6000	Drive voltage (X) error. VENUS 4 AD value error, LENS Unit, LENS flex breaks etc.
				7000	Drive voltage (Y) error. VENUS 4 AD value error, LENS Unit, LENS flex breaks etc.
		C.B./Zoom	0010	HP Low detect error. (HP ENC. detects always low. (Fully retracted condition.)) Zoom motor, ABS ENC., and/or circuit failure. Zoom deadlock (Exit side).	
			0020	HP Low detect error. (HP ENC detects always High. (Exit condition.)) Zoom motor, ABS ENC., and/or circuit failure. Zoom deadlock (Retract side).	
			0030 0040 0050	Zoom ENC. detect error.(No signal is supplied from Encoder located on Zoom Motor.) Zoom motor, ABS ENC., and/or circuit failure. Zoom deadlock.	
		Focus	0001	HP Low detect error (Focus encoder always Low detect error). FP9002-(3) signal line or IC6001 (VENUS 4)	
			0002	HP High detect error (Focus encoder always High detect error). FP9002-(2) signal line or IC6001 (VENUS 4)	
		Lens	18*1	0000	Power ON time out error. Lens drive system
				0000	Power OFF time out error. Lens drive system
	Adj.History	OIS	19*0	2000	OIS adj. Yaw direction amplitude error (small)
				3000	OIS adj. Pitch direction amplitude error (small)
				4000	OIS adj. Yaw direction amplitude error (large)
				5000	OIS adj. Pitch direction amplitude error (large)
				6000	OIS adj. MREF error
				7000	OIS adj. time out error
8000				OIS adj. Yaw direction off set error	
9000				OIS adj. Pitch direction off set error	
A000				OIS adj. Yaw direction gain error	
B000				OIS adj. Pitch direction gain error	
C000				OIS adj. Yaw direction position sensor error	
D000				OIS adj. Pitch direction position sensor error	
E000				OIS adj. other error	

Attribute	Main item	Sub item	Error code		Contents (Upper)	
			High 4 bits	Low 4 bits	Check point (Lower)	
HARD	VENUS A/D	Flash	28*0	0000	Flash charging error. IC6001-(AC17) signal line or Flash charging circuit	
				0001	EEPROM read error IC6002 (FLASH ROM)	
	SYSTEM	RTC	2C*0		0001	SYSTEM IC initialize failure error Communication between IC6001 (VENUS 4) and IC9101 (SYSTEM)
				0002	EEPROM write error IC6002 (FLASH ROM)	
SOFT	CPU	Reset	30*0	0001	NMI reset	
				0007	Non Mask-able Interrupt (30000001-30000007 are caused by factors)	
	Card	Card	31*0	0001	Card logic error SD memory card data line or IC6001 (VENUS 4)	
					0002	Card physical error SD memory card data line or IC6001 (VENUS 4)
					0004	Write error SD memory card data line or IC6001 (VENUS 4)
						Format error
	CPU, ASIC hard	Stop	38*0	0001	Camera task finish process time out. Communication between Lens system and IC6001 (VENUS 4)	
					0002	Camera task invalid code error. IC6001 (VENUS 4)
					0100	File time out error in recording motion image IC6001 (VENUS 4)
					0200	File data send error in recording motion image IC6001 (VENUS 4)
					0300	Single or burst recording brake time out.
	Operation	Power on	3B*0	0000	FLASHROM processing early period of camera during movement.	
	Zoom	Zoom	3C*0	0000	Inperfect zoom lens processing Zoom lens	
					35*0	0000
			35*1	0000		
			35*2	0000	Though record preprocessing is necessary, it is not completed.	

About "*" indication in the above table:

The third digit from the left is different as follows.

- In case of 0 (example: 18001000)

When the third digit from the left shows "0", this error occurred under the condition of INITIAL SETTINGS has been completed.

It means that this error is occurred basically at user side.

- In case of 8 (example: 18801000)

When the third digit from the left shows "8", this error occurred under the condition of INITIAL SETTINGS has been released.

(Example; Factory assembling-line before unit shipment, Service mode etc.)

It means that this error is occurred at service side.

• 6. How to returned to Normal Display:

Turn the power off and on, to exit from Error code display mode.





NOTE:

The error code can not be initialized.

7 Service Fixture & Tools

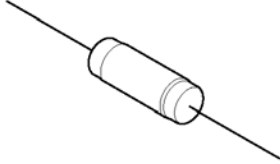
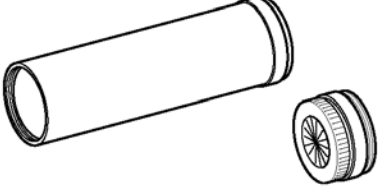
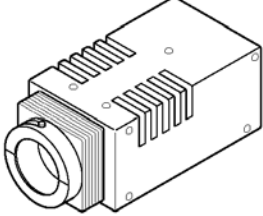
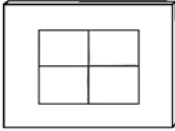
7.1. Service Fixture and Tools

The following Service Fixture and tools are used for checking and servicing this unit.

Resistor for Discharging ERG5SJ102	Infinity Lens (with Focus Chart) VFK1164TCM02	LIGHT BOX VFK1164TDVLB
 An equivalent type of Resistor may be used.	 * RFKZ0422 can be used.	 ※ with DC Cable
TR Chart RFKZ0443	Lens Cleaning Kit (BK) VFK1900BK	Grease (for lens) RFKZ0472
	 * Only supplied as 10 set/box.	
Furoyl grease (for focus motor) VFK1850	Dome type magnifying glass VFK1835	
		

7.2. When Replacing the Main PCB

After replacing the MAIN PCB, be sure to achieve adjustment.

The adjustment instruction is available at “software download” on the “Support Information from NWBG/VDBG-PAVC” web-site in “TSN system”, together with Maintenance software.

7.3. Service Position

This Service Position is used for checking and replacing parts. Use the following Extension cables for servicing.

Table S1 Extension Cable List

No.	Parts No.	Connection	Form
1	RFKZ0354	FP9103 (MAIN) - LCD UNIT	37PIN 0.3 FFC
2	VFK1974	FP9004 (MAIN) - LCD UNIT	4PIN 0.5 FFC
3	RFKZ0416	FP9001 (MAIN) - CCD UNIT	41PIN 0.3 FFC
4	RFKZ0477	FP9002 (MAIN) - LENS UNIT	45PIN 0.3 FFC
5	RFKZ0418	PP9001 (MAIN) - PS8001 (FLASH TOP)	30PIN B to B

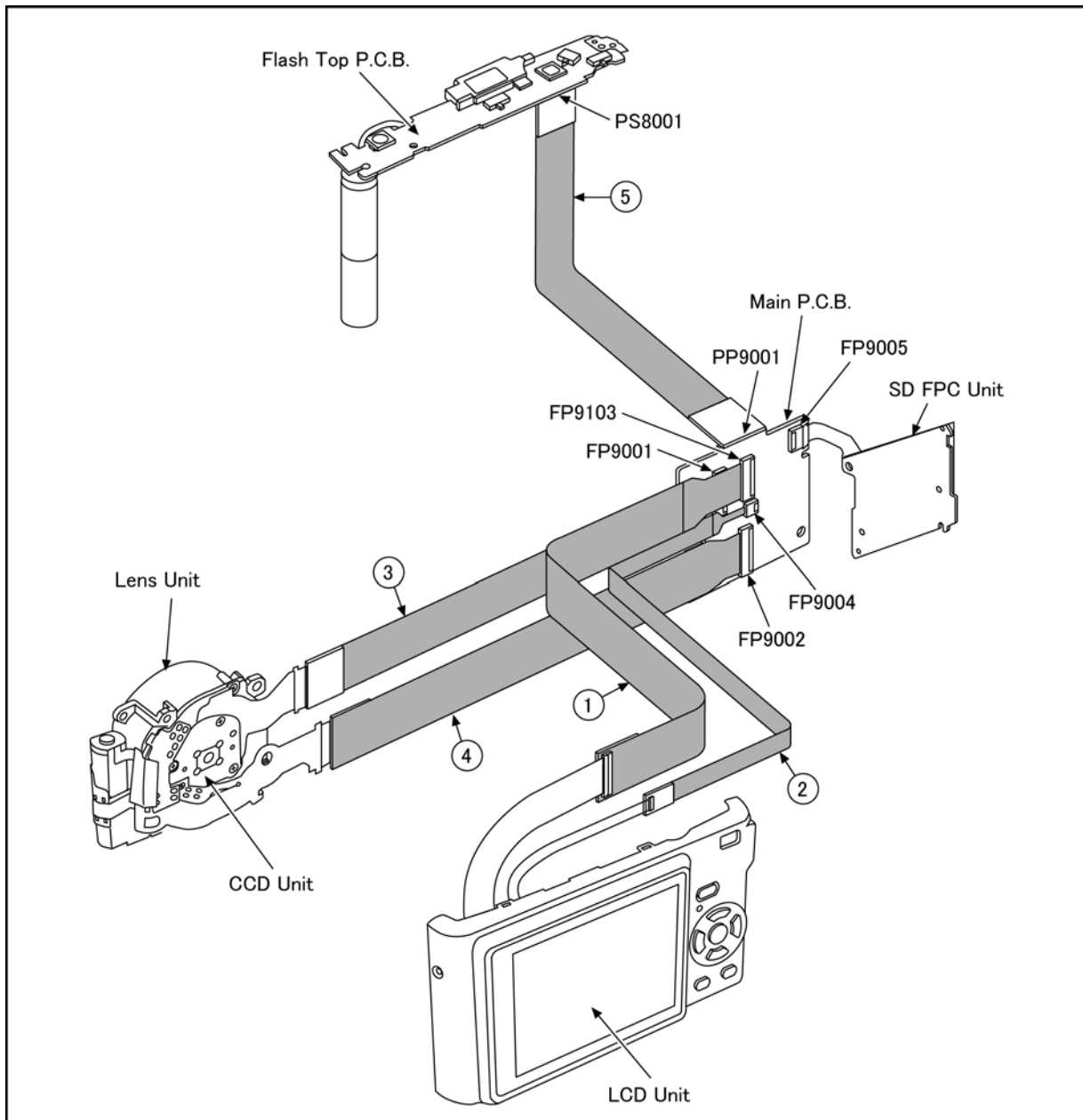

CAUTION-1. (When servicing FLASH TOP PCB)

1. Be sure to discharge the capacitor on FLASH TOP PCB.
Refer to “HOW TO DISCHARGE THE CAPACITOR ON FLASH TOP PCB”.
The capacitor voltage is not lowered soon even if the AC Cord is unplugged or the battery is removed.
2. Be careful of the high voltage circuit on FLASH TOP PCB.
3. DO NOT allow other parts to touch the high voltage circuit on FLASH TOP PCB.

8 Disassembly and Assembly Instructions

8.1. Disassembly Flow Chart

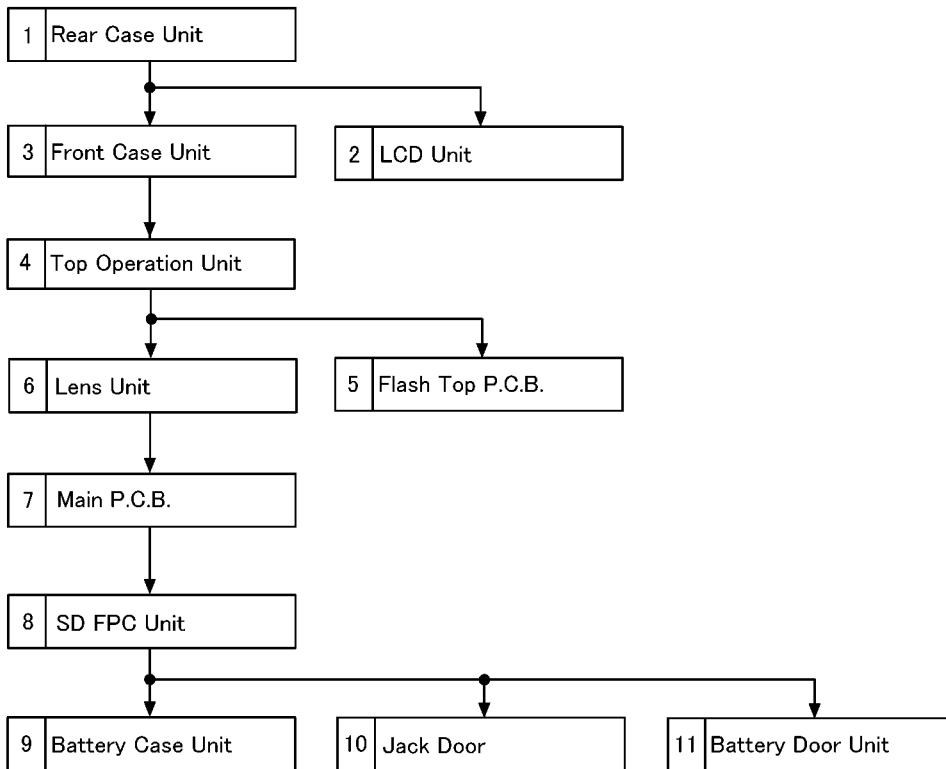

8.2. PCB Location

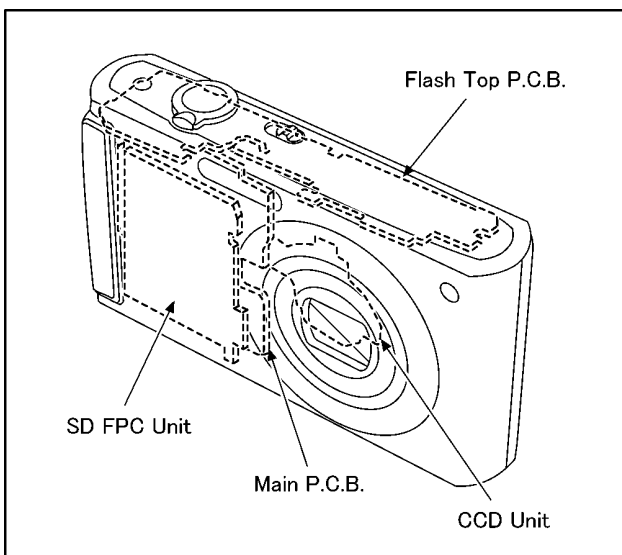

8.3. Disassembly Procedure

No.	Item	Fig	Removal
1	Rear Case Unit	Fig.D1	Card
			Battery
			1 Screw (A)
			3 Screws (B)
			1 Lock A
		2 Locks B	
		Fig.D2	FP9004(Flex)
			FP9103(Flex)
			Rear Case Unit
2	LCD Unit	Fig.D3	2 Locking tabs LCD Unit
3	Front Case Unit	Fig.D4	1 Screw (C)
			3 Screws (D)
			2 Locking tabs
			Front Case Unit
4	Top Operation Unit	Fig.D5	PS8001(Connector) Top Operation Unit
5	Flash Top P.C.B.	Fig.D6	AF Panel Light
			2 Screws (E)
			3 Locking tabs
			Mode Knob
			Top Ornament Unit
			Speaker
			Mic Damper
		Power knob base	
		Power knob	
		Fig.D7	Flash Top P.C.B.
6	Lens Unit	Fig.D8	3 Screws (F)
			1 Screw (G)
			Frame Plate
			Tripod Fixing Plate
			FP9001(Flex)
			FP9002(Flex)
			Lens Unit
7	Main P.C.B.	Fig.D9	1 Screw (H)
			FP9005(Flex)
			PCB Spacer
			Main P.C.B.
8	SD FPC Unit	Fig.D10	1 Screw (I) SD FPC Unit
9	Battery Case Unit	Fig.D11	Battery Out Spring
			Battery Case Unit
10	Jack Door	Fig.D12	Jack Door Shaft
			Jack Door
11	Battery Door Unit	Fig.D13	Battery Door Shaft
			Battery Door Spring
			Battery Door Unit

8.3.1. Removal of the Rear Case Unit

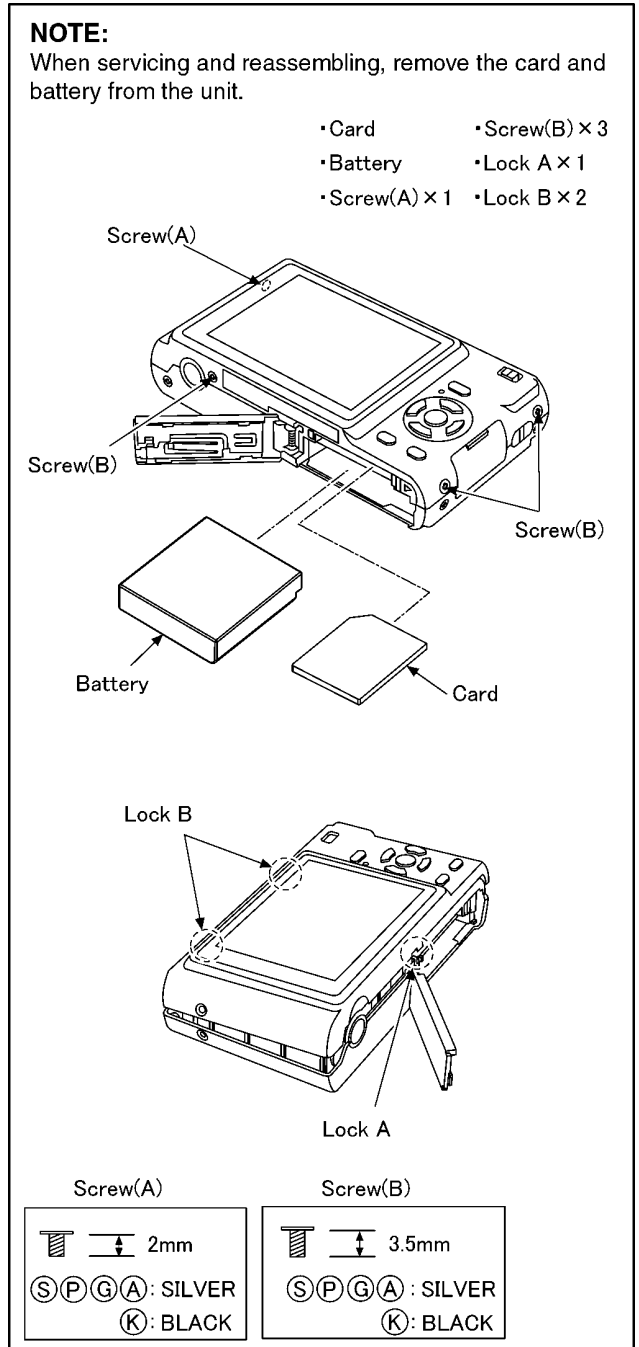

Fig.D1

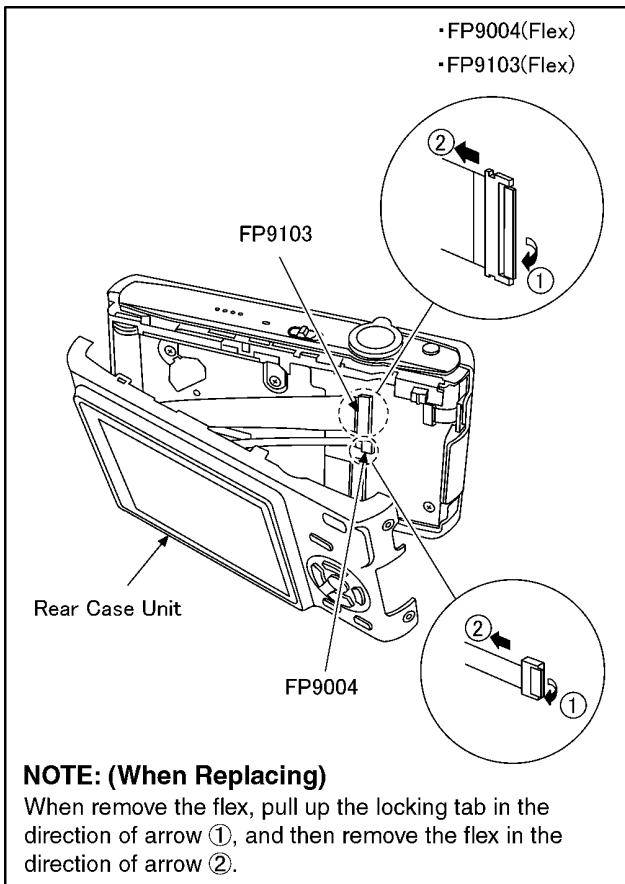

Fig.D2

8.3.2. Removal of the LCD Unit

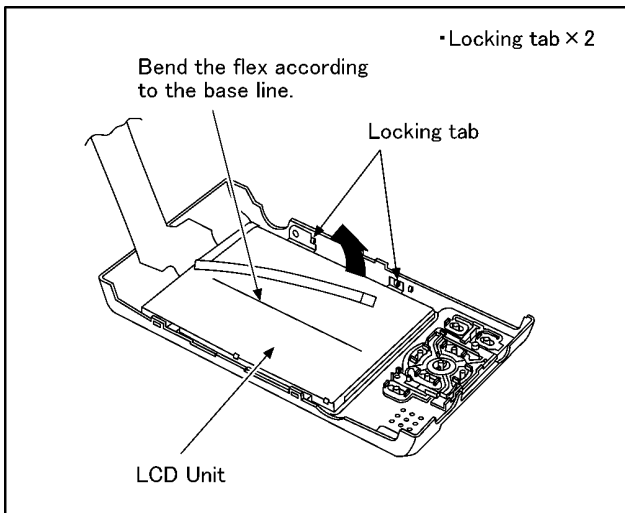

Fig.D3

8.3.3. Removal of the Front Case Unit

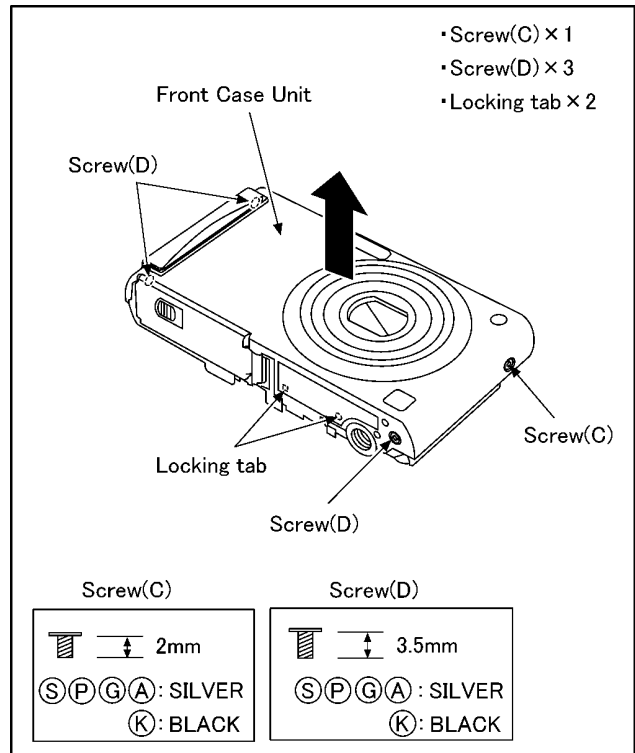

Fig.D4

8.3.4. Removal of the Top Operation Unit

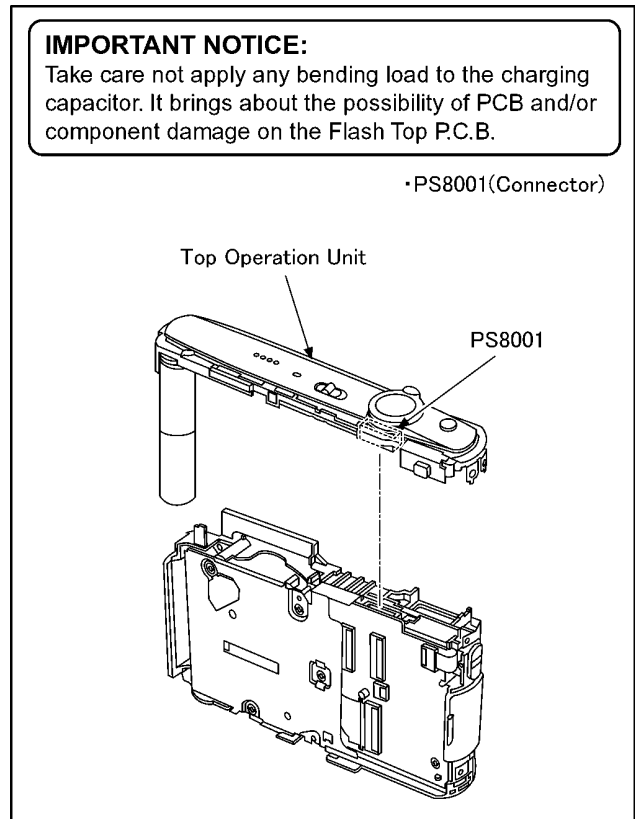

Fig.D5

8.3.5. Removal of the Flash Top P.C.B.

IMPORTANT NOTICE:

Take care not apply any bending load to the charging capacitor. It brings about the possibility of PCB and/or component damage on the Flash Top P.C.B.

- AF Panel Light
- Screw(E) × 2
- Locking tab × 3
- Mode knob
- Top Ornament Unit
- Speaker
- Mic Damper
- POWER knob base
- POWER knob

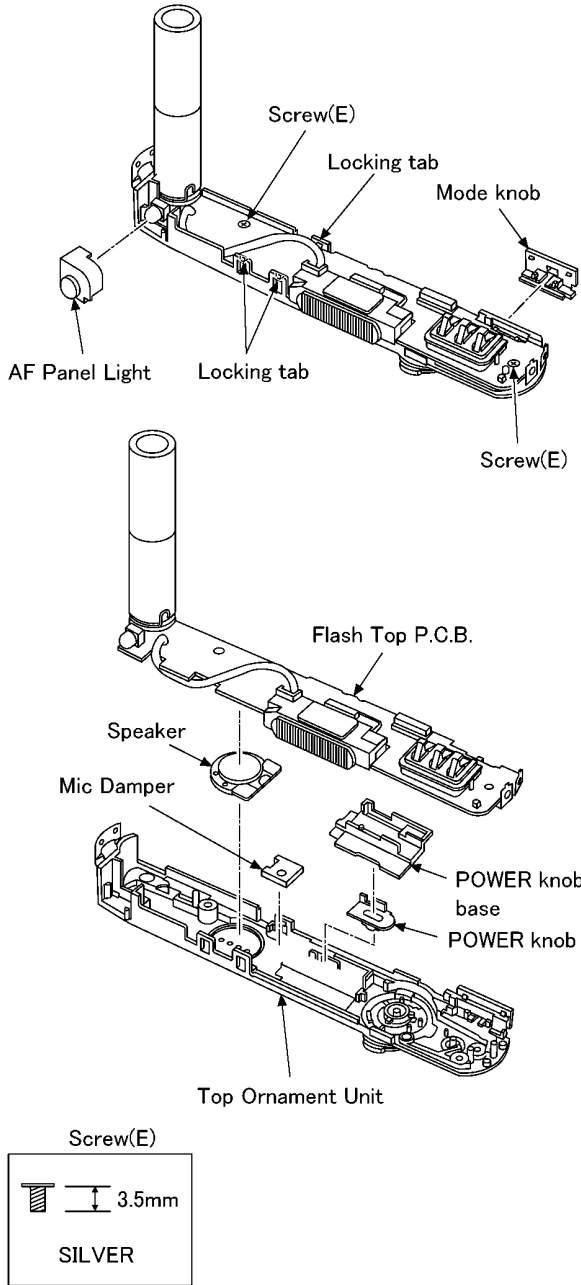
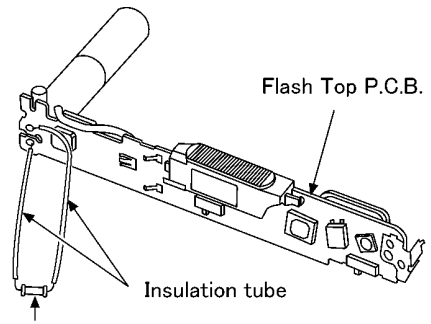

Fig.D6



Resistor for discharging
(1kΩ / 5W)



CAUTION

Be sure to discharge the capacitor on Flash Top P.C.B. before disassembling.

1. Remove the Flash Top P.C.B..
2. Put the insulation tube on the lead part of resistor (ERG5SJ102: 1kΩ/5W).
3. Put the resistor between both terminals of capacitor unit for approx. 5 seconds.

NOTE: (When Installing)

- Align the convex of power switch and power knob.
- Align the convex of mode switch and mode knob.

IMPORTANT NOTICE:

Take care not apply any bending load to the charging capacitor. It brings about the possibility of PCB and/or component damage on the Flash Top P.C.B.

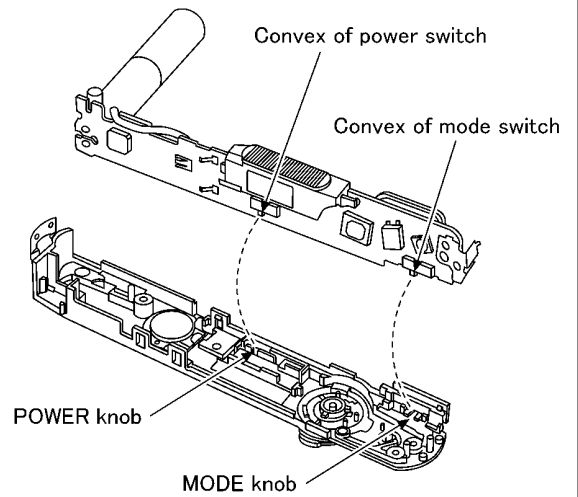

Fig.D7

8.3.6. Removal of the Lens Unit

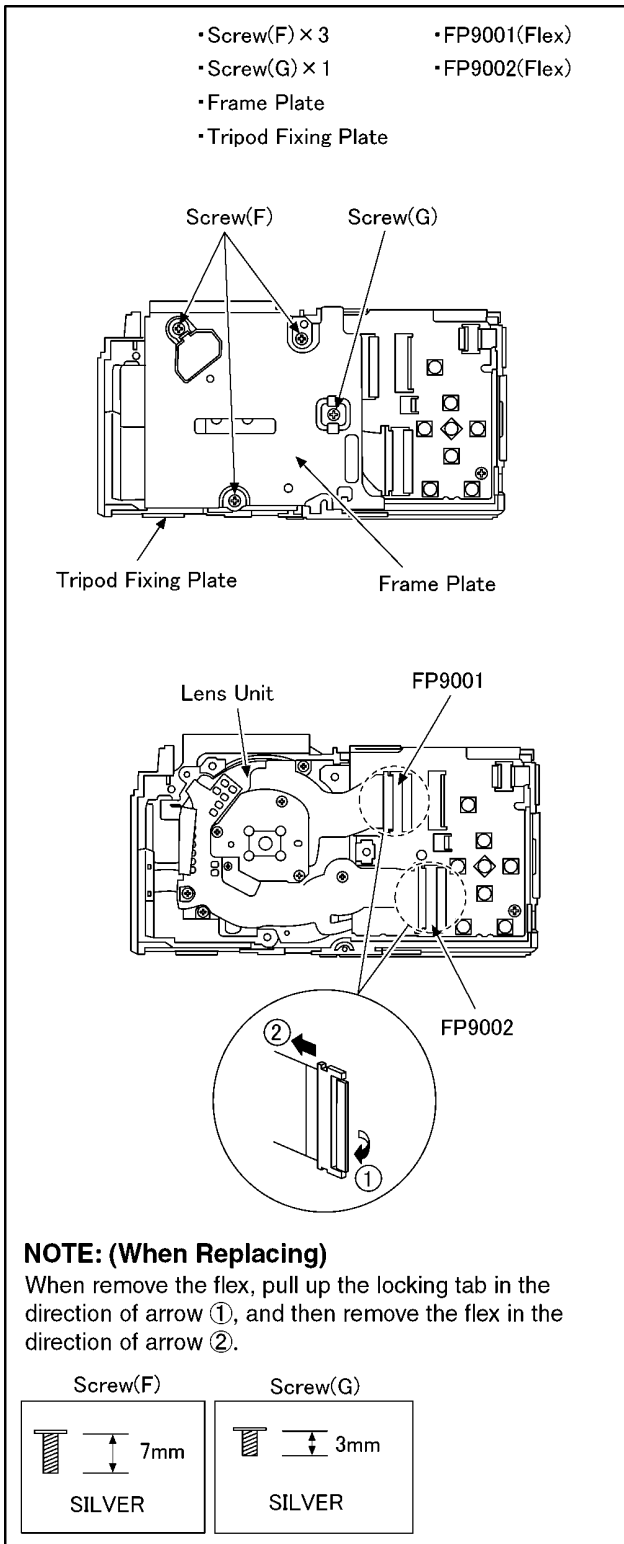

Fig.D8

8.3.7. Removal of the Main P.C.B.

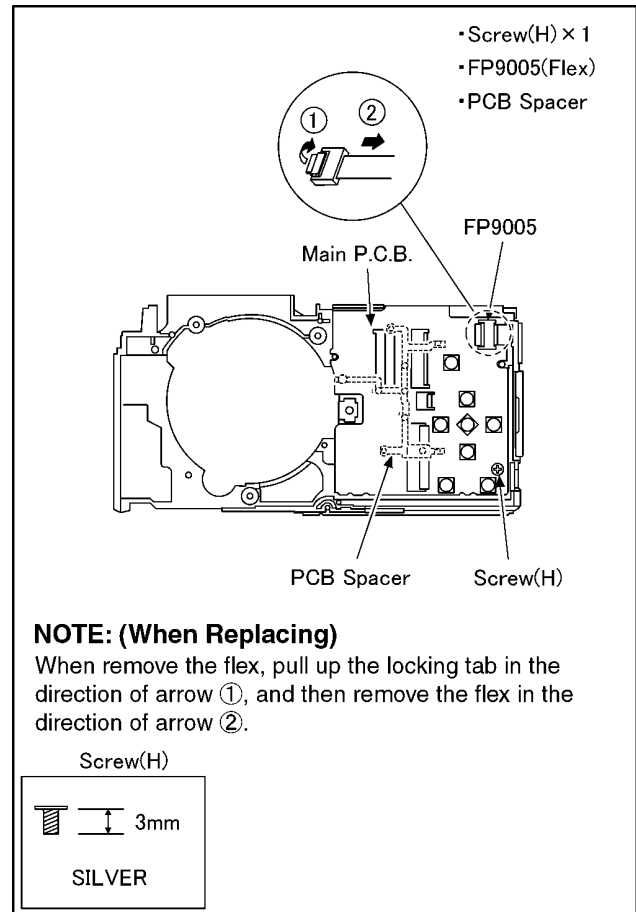

Fig.D9

8.3.8. Removal of the SD FPC Unit

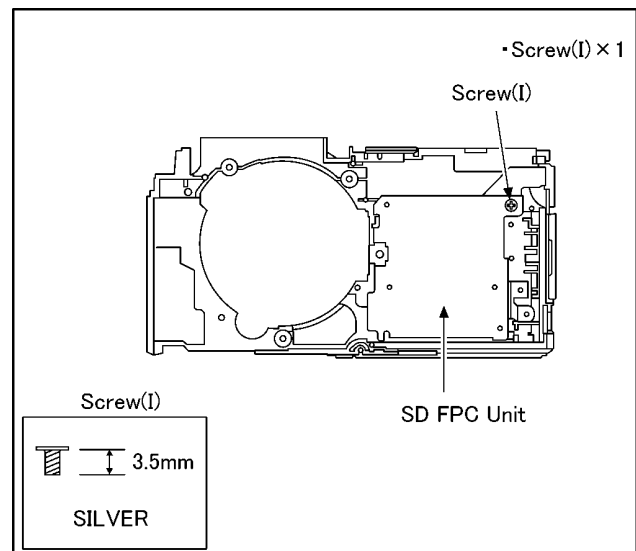

Fig.D10

8.3.9. Removal of the Battery Case Unit

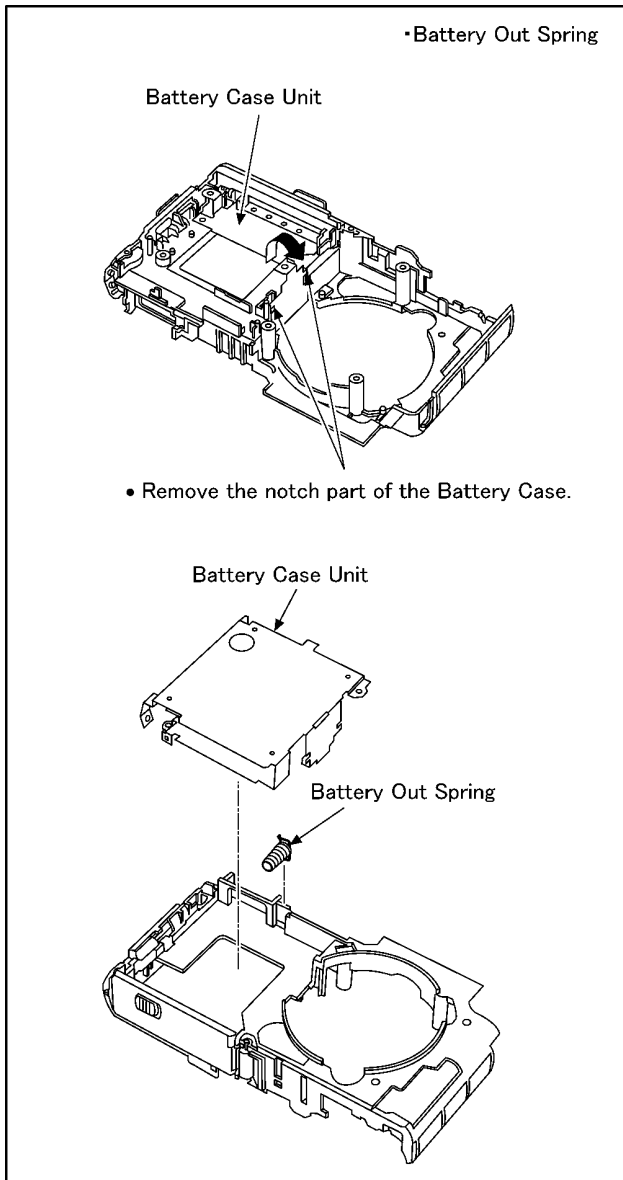

Fig.D11

8.3.10. Removal of the Jack Door

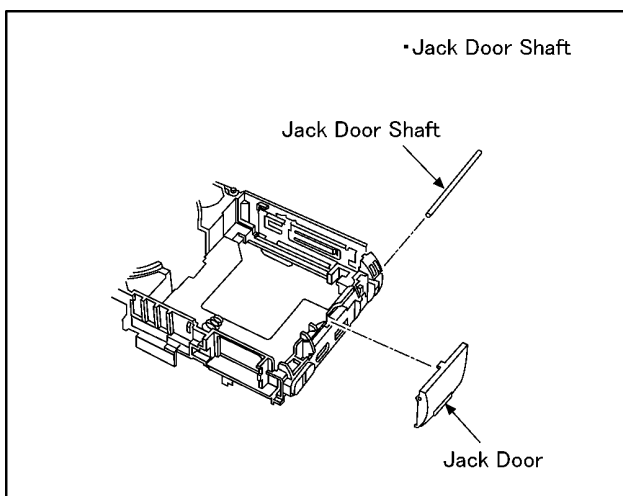

Fig.D12

8.3.11. Removal of the Battery Door Unit

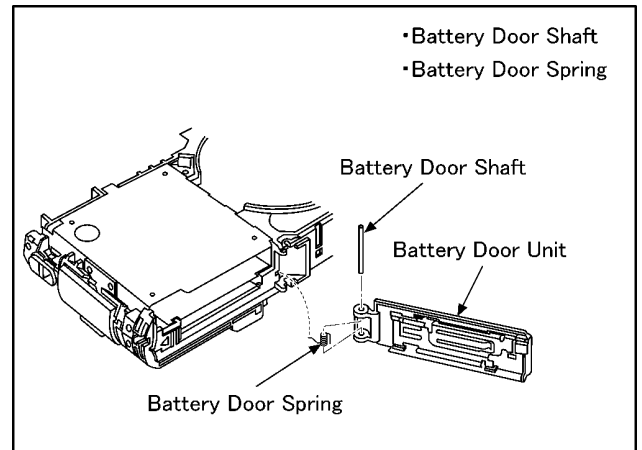

Fig.D13

NOTE: (When Assembling)

Be sure to confirm the following points when assembling.

- The Screw is tightened enough.
- Assembling conditions are fine. (No distortion, no illegal-space.)
- No dust and/or dirt on every Lens surfaces.
- LCD image is fine. (No dust and dirt on it, and no gradient images.)

8.4. Disassembly Procedure for the Lens

NOTE: When Disassembling and Assembling for the Lens

1. To minimize the possibility of the CCD being dirt, perform disassemble and/or assemble under the condition of the CCD is being mounted.
Disassembling procedures for the CCD unit, refer to item 8.6.
2. Take care that the dust and dirt are not entered into the lens.
In case of the dust is putted on the lens, blow off them by airbrush.
3. Do not touch the surface of lens.
4. Use lens cleaning KIT (BK)(VFK1900BK).
5. Apply the grease (RFKZ0472/VFK1850) to the point where is shown to "Grease apply" in the figure.
When the grease is applied, use a toothpick and apply thinly.
6. When repair the fixed frame, drive frame and direct frame, must be unit exchange.

8.4.1. Removal of the Zoom Motor Unit and Lens Flex P.C.B. Unit

1. Remove the 1 solder (A).
2. Remove the 3 locks.
3. Unscrew the 2 screws (A).
4. Remove the zoom motor unit to the indicated by arrow.
5. Remove the 1 solder (B).
6. Unscrew the 1 screw (B).
7. Remove the lens flex to the indicated by arrow.

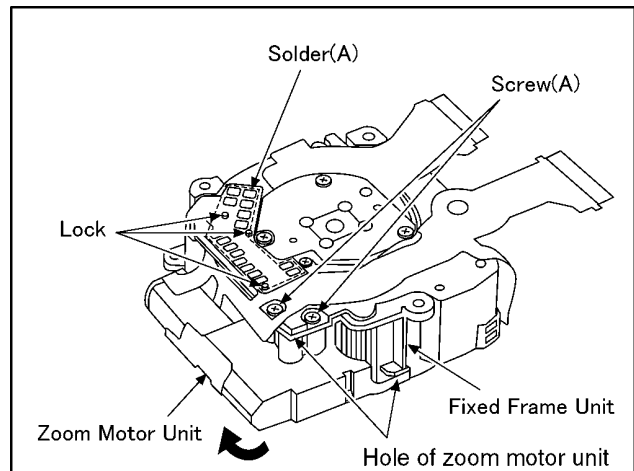

NOTE: (When Assembling)

- Align the convex of fixed frame unit and hole of zoom motor unit, and then install them.

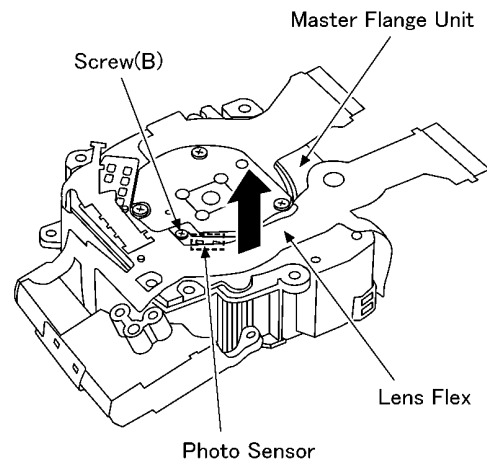
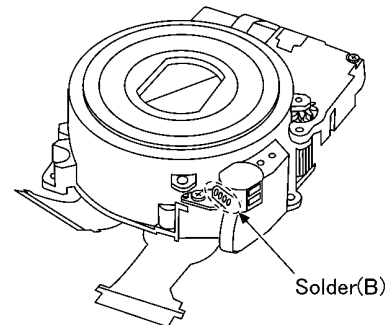

NOTE: (When Assembling)

- Take care not to damage the flex.

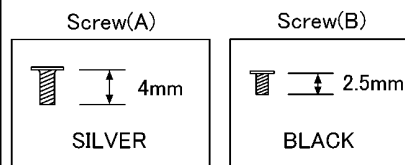

8.4.2. Removal of the Master Flange Unit

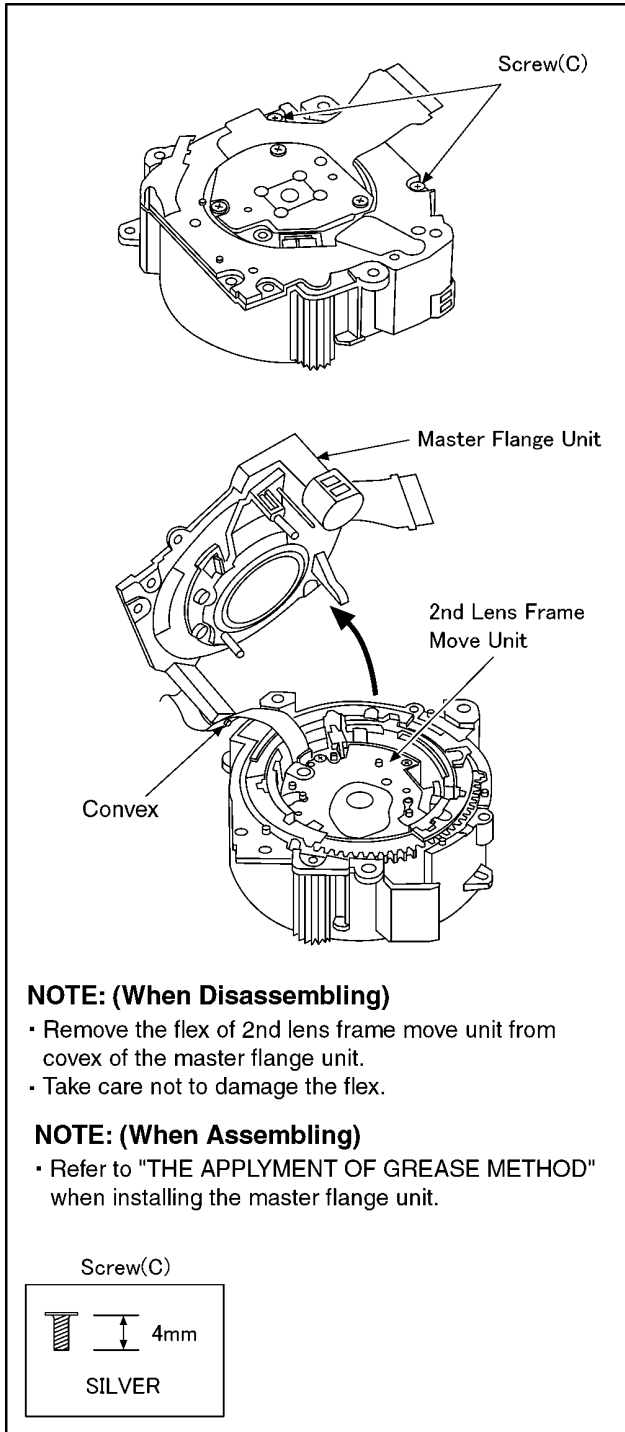

8.4.3. Removal of the 1st Lens Frame/2nd Lens Frame Move Unit

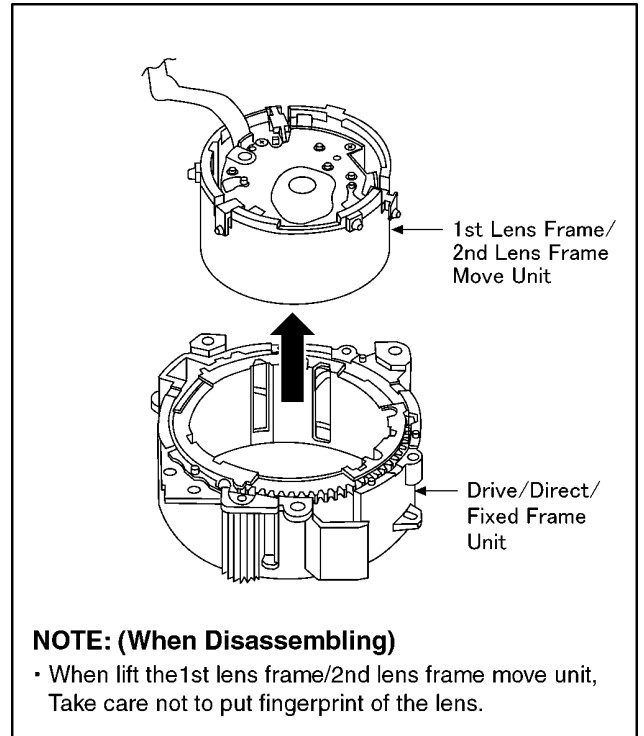

8.4.4. Removal of the 2nd Lens Frame Move Unit

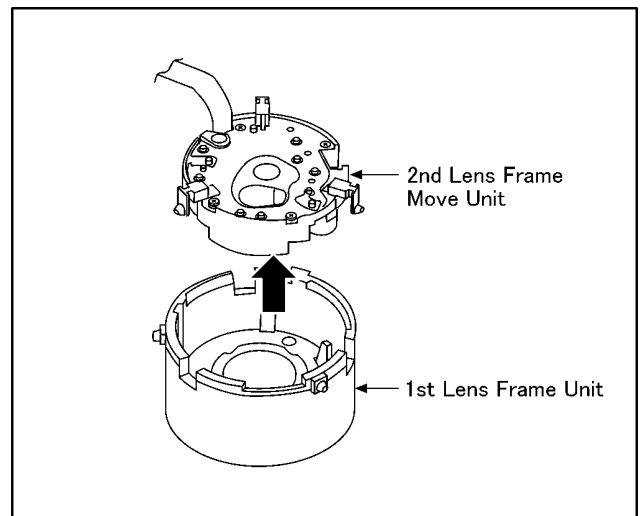

8.4.5. Removal of the Drive/Direct Frame Unit

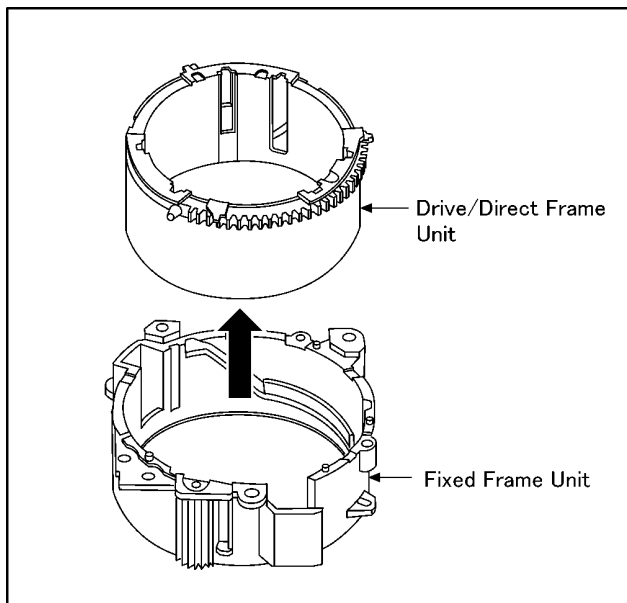

8.5. Assembly Procedure for the Lens

8.5.1. Phase alignment of the Direct Frame and Drive Frame Unit

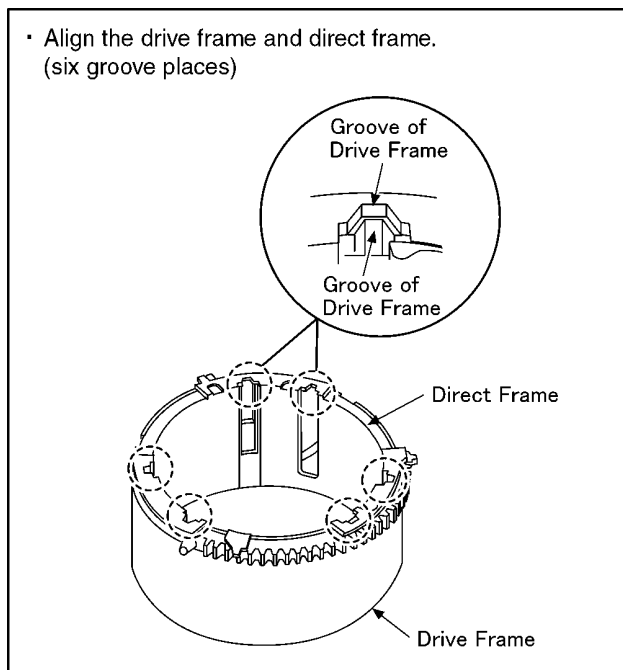

8.5.2. Phase alignment of the Drive/Direct Unit and Fixed Frame Unit

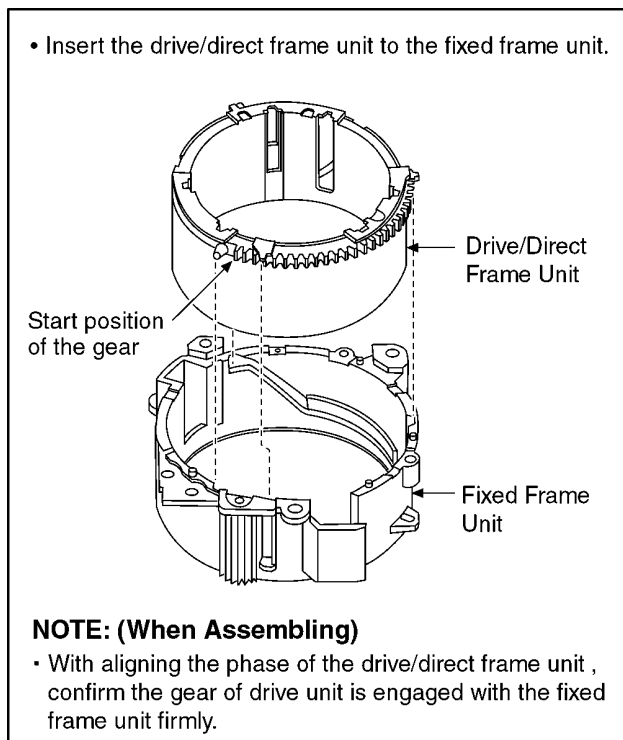

8.5.3. Assembly for the 1st Lens Frame Unit and Fixed/Drive/Direct Frame Unit

Barrier Drive Lever

- Inserts the 1st lens frame unit to the drive/direct/fixed frame unit so that the barrier drive lever may become the position of the figure below.

Barrier Drive Lever

1st Lens Frame Unit

Drive/Direct/Fixed Frame Unit

NOTE: (When Assembling)
Take care not to put fingerprint of the lens.

FRONT VIEW

- Install the 1st lens frame unit so that the "LEICA" character may become the position of the figure below.

"LEICA" character

1st Lens Frame Unit

LEICA

Fixed Frame Unit

8.5.4. Assembly for the 2nd Lens Frame Move Unit and Fixed/Drive/Direct Frame/1st Lens Frame Unit

- Inset the 2nd frame move unit to the Fixed/Drive/Direct 1st Lens Frame Unit.

Flex

2nd Lens Frame Move Unit

ND Filter

Fixed/Drive/Direct 1st Lens Frame Unit

NOTE: (When Assembling)
Take care not to put fingerprint of the ND filter and lens.

Gear

NOTE: (When Assembling)

- Turn the gear of the fixed frame unit in the direction of the arrow, and then confirm to operate smoothly.

8.5.5. Assembly for the Master Flange Unit and Fixed/Drive/Direct Frame/1st Lens Frame/2nd Lens Frame Move Unit

- Align the flex insert part of fixed frame unit and convex of the master flange unit, and then insert the master flange unit.

Insert the convex to positioning hole of FPC

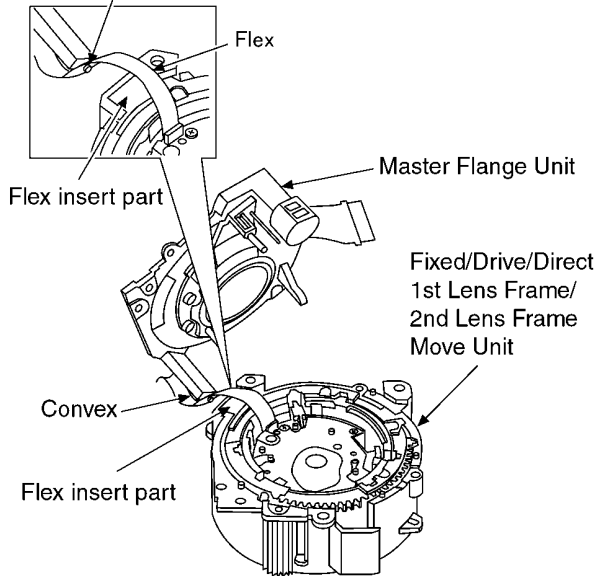

NOTE: (When Assembling)

- Take care not to damage the flex.
- Refer to "THE APPLYMENT OF GREASE METHOD" when installing the master flange unit.
- Turn the Drive Gear in the direction of an arrow, and then confirm the lens shutter is closed.

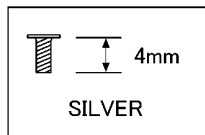
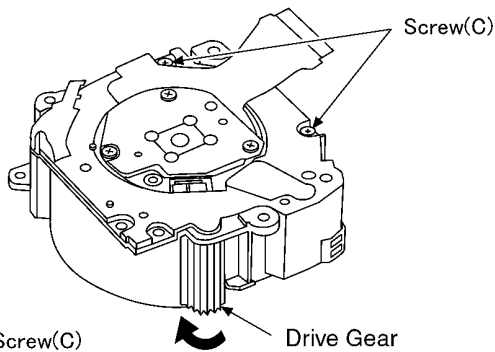
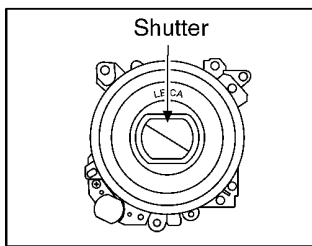

8.6. Removal of the CCD Unit

To prevent the CCD unit from catching the dust and dirt, do not remove the CCD unit except for replacing.

- Screw(D) × 3
- CCD Cushion × 1
- Optical Filter × 1

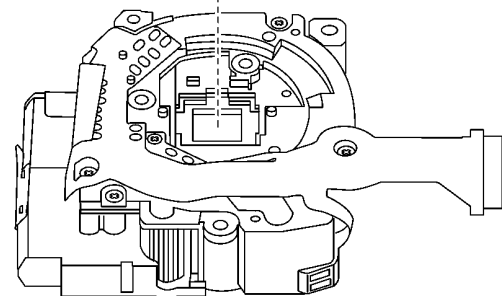
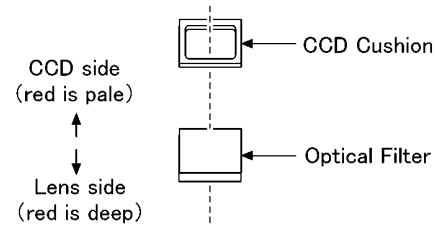
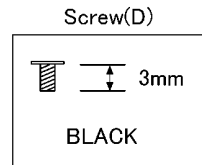
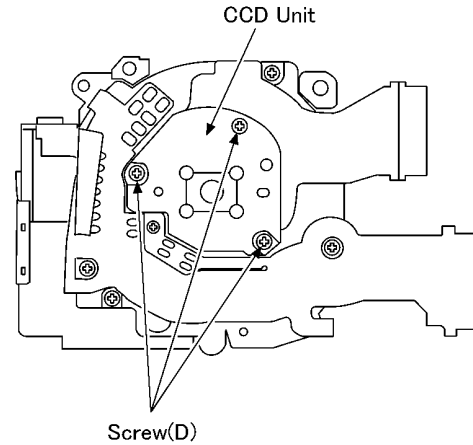

NOTE: (When Assembling)

Definitions of mount side of Optical filter.

*Set the optical filter under the condition of reflecting the fluorescent lamp can be seen by your eyes.

*Although depth of the red color may be changed in accordance with seeing angle, compare the deepest red color in both sides to define each side.

Lens side: red color is deeper than the other side.

CCD side: red color is paler than the other side.

It can be easy to confirm the red color density on the blue paper.

*The optical filter might stuck to CCD unit.

When replace the CCD unit, remove the optical filter, and then install it with CCD unit.

8.7. Removal of the Focus Motor Unit

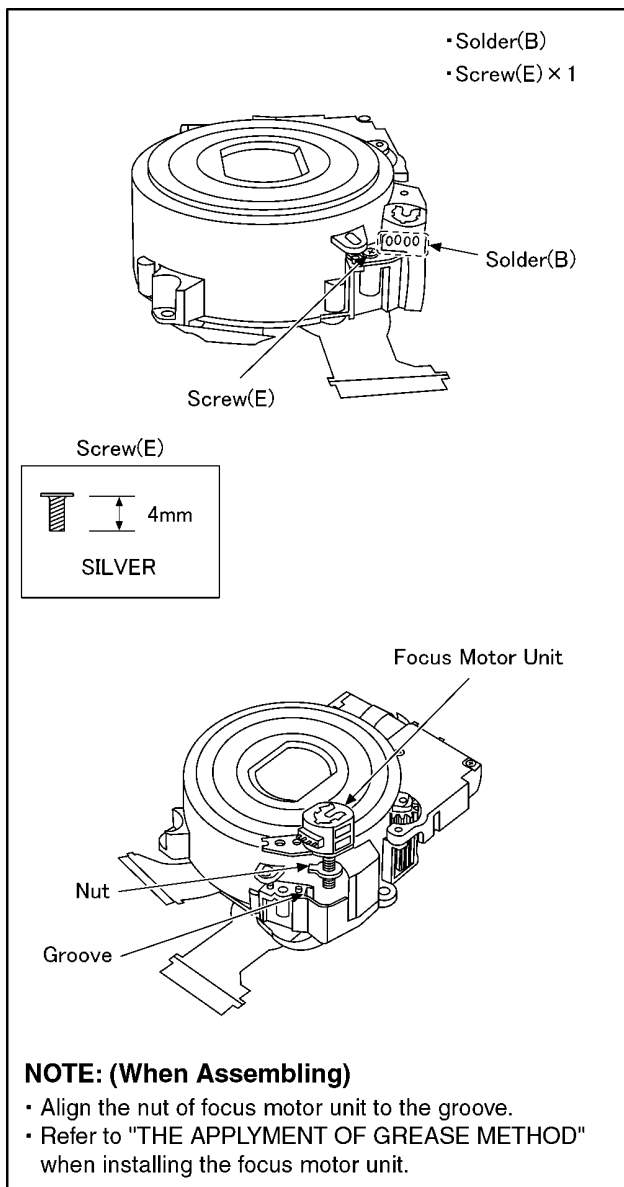

8.8. The Applyment of Grease Method

The grease apply point of lens unit are as follows.
Apply grease additionally in the specified position if necessary.
When the grease is applied, use a toothpick and apply thinly.

- Lead screw
 - Grease: VFK1850 (Furoyl type)
 - Amount of apply: 2 - 4 mg
- Guide pole/Fasten groove of nut
 - Grease: RFKZ0472
 - Amount of apply: 2 - 4 mg

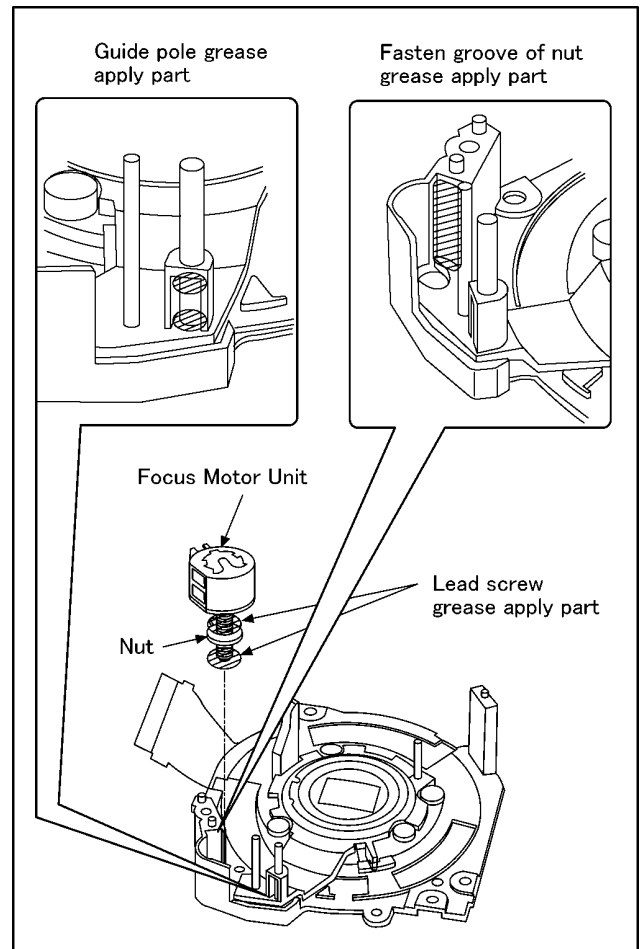

9 Measurements and Adjustments

9.1. Matrix Chart for Replaced Part and Necessary Adjustment

The relation between Replaced part and Necessary Adjustment is shown in the following table.

When concerned part is replaced, be sure to achieve the necessary adjustment(s).

As for Adjustment condition/procedure, consult the "Adjustment Manual" which is available in Adjustment software.

The Adjustment software is available at "TSN Website", therefore, access to "TSN Website" at "Support Information from NWBG/VDBG-PAVC".

NOTE:

After adjustments have been terminated, make sure to achieve "INITIAL SETTINGS".

Adjustment Item		Replaced Part				
		Main P.C.B.	VENUS (IC6001)	Flash-ROM (IC6002)	Lens Part (Excluding CCD)	CCD Unit
Camera Section	OIS hall element adjustment (OIS)	○	○	○	○	—
	Back focus adjustment (BF)	○	○	○	○	○ ^{*1}
	Shutter adjustment (SHT)	○	○	○	○	○
	ISO sensitivity adjustment (ISO)	○	○	○	○	○
	AWB adjustment High brightness coloration inspection (WBL)	○	○	○	○	○
	CCD white scratch compensation (WKI)	○	○	○	—	○ ^{*1}
	CCD black scratch compensation (BKI)	○	○	○	—	○ ^{*1}

*1: This adjustment is necessary, not only replacing CCD unit but also removing it from the lens unit.

NOTE:

*There is no LCD adjustment in this model.

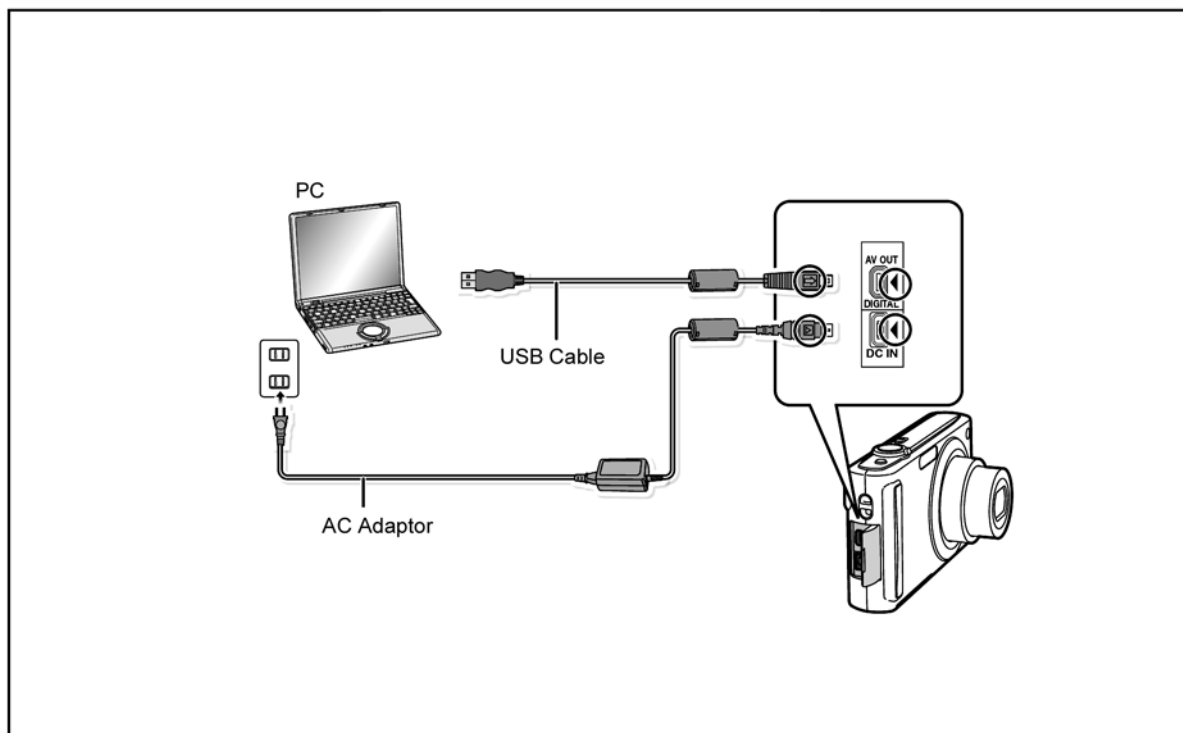

10 Maintenance

10.1. Cleaning Lens and LCD Panel

Do not touch the surface of lens and LCD Panel with your hand.

When cleaning the lens, use air-Blower to blow off the dust.

When cleaning the LCD Panel, dampen the lens cleaning paper with lens cleaner, and the gently wipe the their surface.

Note:

The Lens Cleaning KIT ; VFK1900BK (Only supplied as 10 set/Box) is available as Service Aid.

Service Manual

Diagrams and Replacement Parts List

Digital Camera

Model No.

DMC-FS3P	DMC-FS3EG
DMC-FS3PC	DMC-FS3GC
DMC-FS3PL	DMC-FS3GD
DMC-FS3PR	DMC-FS3GK
DMC-FS3E	DMC-FS3GN
DMC-FS3EB	DMC-FS3GT
DMC-FS3EE	DMC-FS3GJ
DMC-FS3EF	

Vol. 1

Colour

- (S).....Silver Type (except PR)
- (K).....Black Type (except P/GT)
- (P).....Pink Type (except GD/GK)
- (A).....Blue Type (except GC/GD/GK/GN/GT/GJ)
- (G).....Green Type (only P)

Table of contents

S1. About Indication of The Schematic Diagram..... S-1	S6. Replacement Parts List.....S-13
S1.1. Important Safety Notice..... S-1	
S2. Voltage Chart S-2	S7. Exploded View.....S-19
S2.1. Flash Top P.C.B..... S-2	S7.1. Frame and Casing Section.....S-19
S3. Block Diagram..... S-3	S7.2. Packing Parts and Accessories Section (1).....S-20
S3.1. Overall Block Diagram S-3	S7.3. Packing Parts and Accessories Section (2).....S-21
S4. Schematic Diagram..... S-4	
S4.1. Interconnection Diagram S-4	
S4.2. Flash Top Schematic Diagram S-5	
S4.3. SD Flex Schematic Diagram S-6	
S4.4. CCD Flex Schematic Diagram S-7	
S4.5. Lens Flex Schematic Diagram S-8	
S5. Print Circuit Board S-9	
S5.1. Flash Top P.C.B..... S-9	
S5.2. SD Flex P.C.B. S-10	
S5.3. CCD Flex P.C.B..... S-10	
S5.4. Lens Flex P.C.B..... S-11	

S1. About Indication of The Schematic Diagram

S1.1. Important Safety Notice

COMPONENTS IDENTIFIED WITH THE MARK \triangle HAVE THE SPECIAL CHARACTERISTICS FOR SAFETY. WHEN REPLACING ANY OF THESE COMPONENTS USE ONLY THE SAME TYPE.

1. Although reference number of the parts is indicated on the P.C.B. drawing and/or schematic diagrams, it is NOT mounted on the P.C.B. when it is displayed with "\$" mark.
2. It is only the "Test Round" and no terminal (Pin) is available on the P.C.B. when the TP (Test Point) indicated as "●" mark.
3. The voltage being indicated on the schematic diagram is measured in "Standard-Playback" mode when there is no specify mode is mentioned.
4. Although the voltage and waveform available on here is measured with standard frame, it may be differ from actual measurement due to modification of circuit and so on.
5. The voltage being indicated here may be include observational-error (deviation) due to internal-resistance and/or reactance of equipment. Therefore, handle the value indicated on here as reference.
6. Use the parts number indicated on the Replacement Parts List .
7. Indication on Schematic diagrams:

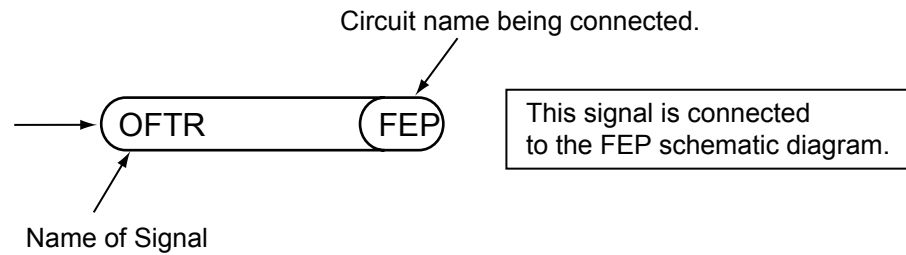

S2. Voltage Chart

Note) Indicated voltage values are the standard values for the unit measured by the DC electronic circuit tester (high-impedance) with the chassis taken as standard.
Therefore, there may exist some errors in the voltage values, depending on the internal impedance of the DC circuit tester.

S2.1. Flash Top P.C.B.

REF No.	PIN No.	POWER ON
IC8001	1	4.2
IC8001	2	0
IC8001	3	0
IC8001	4	0
IC8001	5	4.2
Q8009	1	4.3
Q8009	2	4.3
Q8009	3	0
Q8009	4	0
Q8009	5	4.3
Q8009	6	4.3

S3. Block Diagram

S3.1. Overall Block Diagram

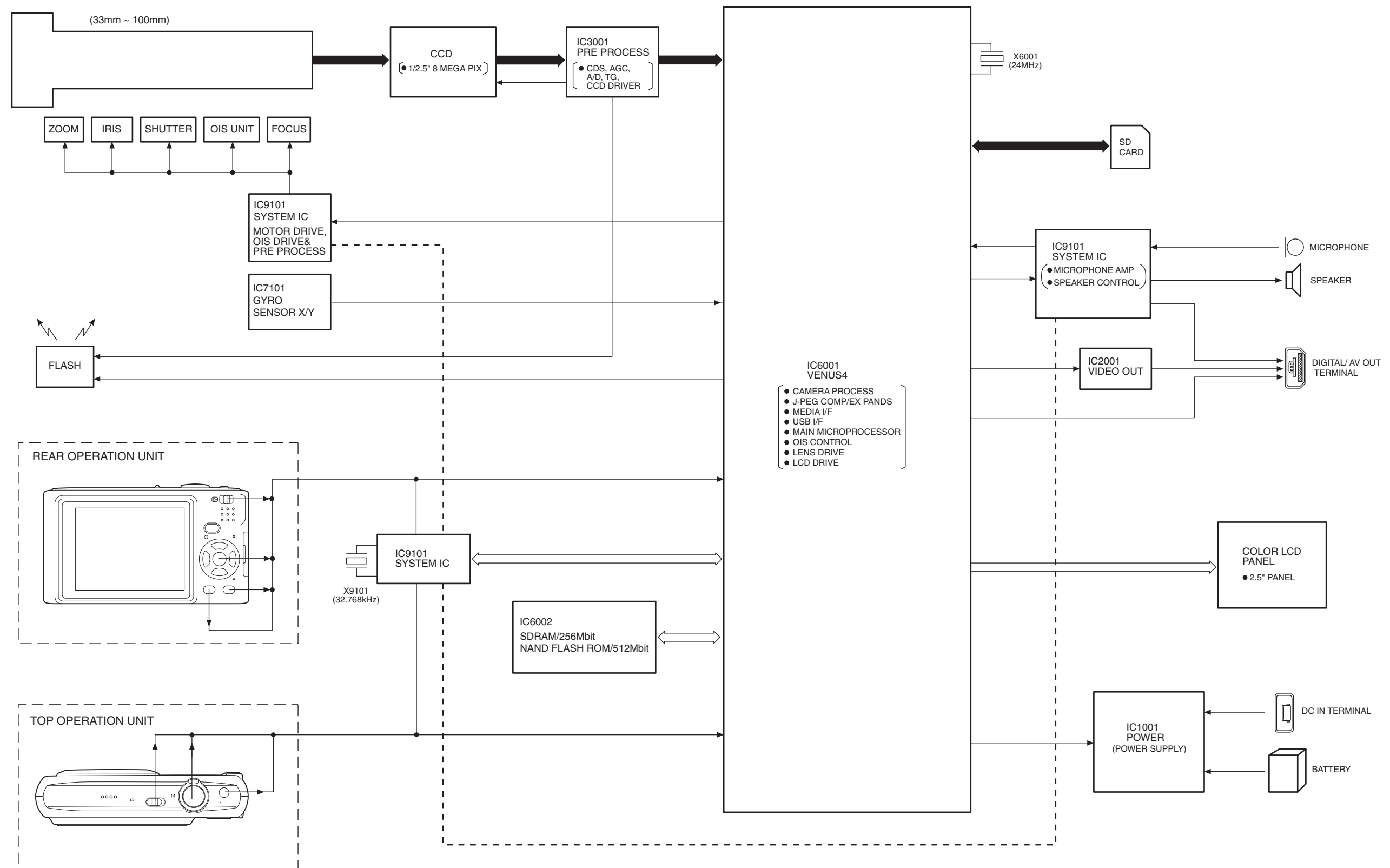

S4. Schematic Diagram

S4.1. Interconnection Diagram

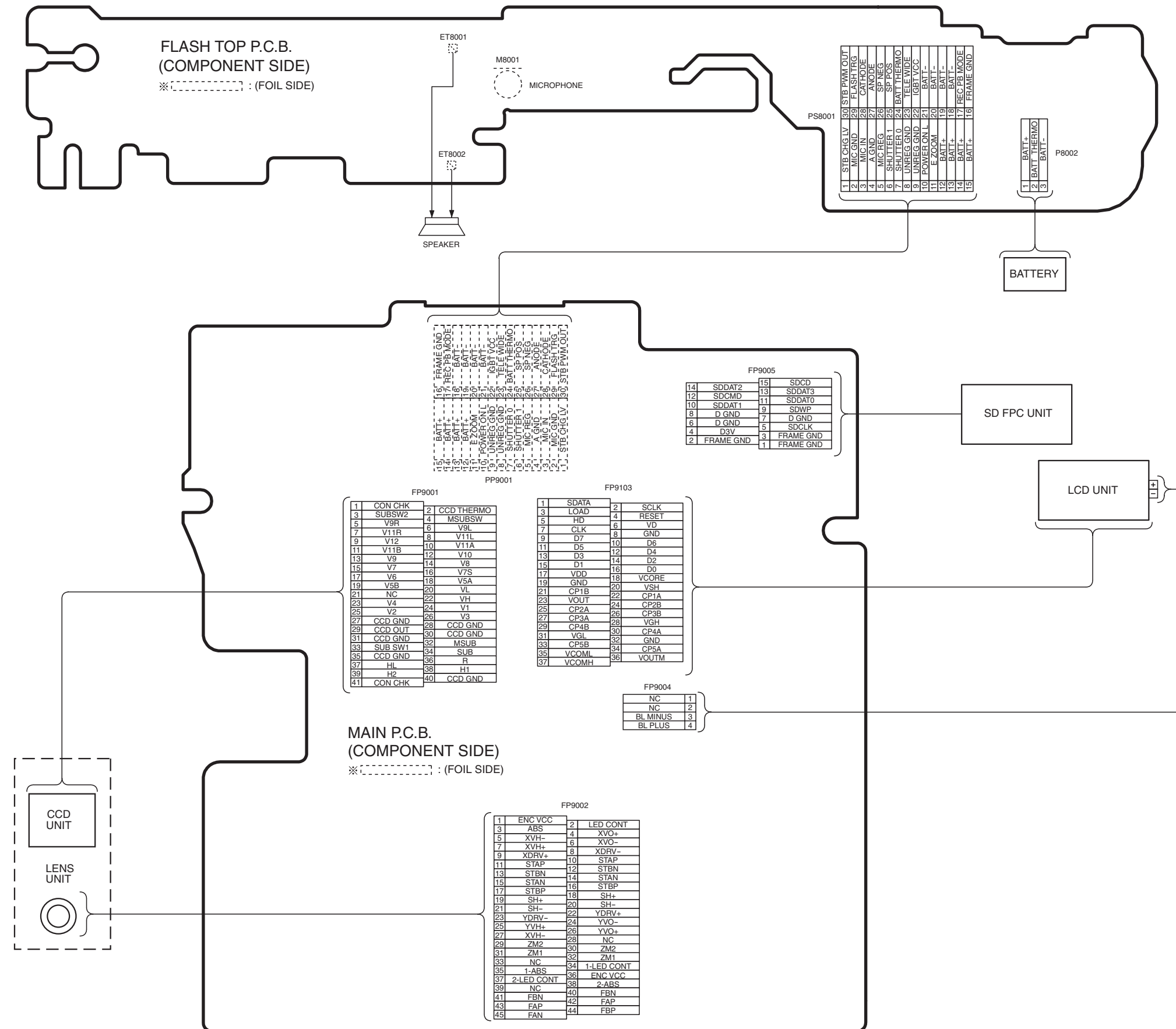

S4.2. Flash Top Schematic Diagram

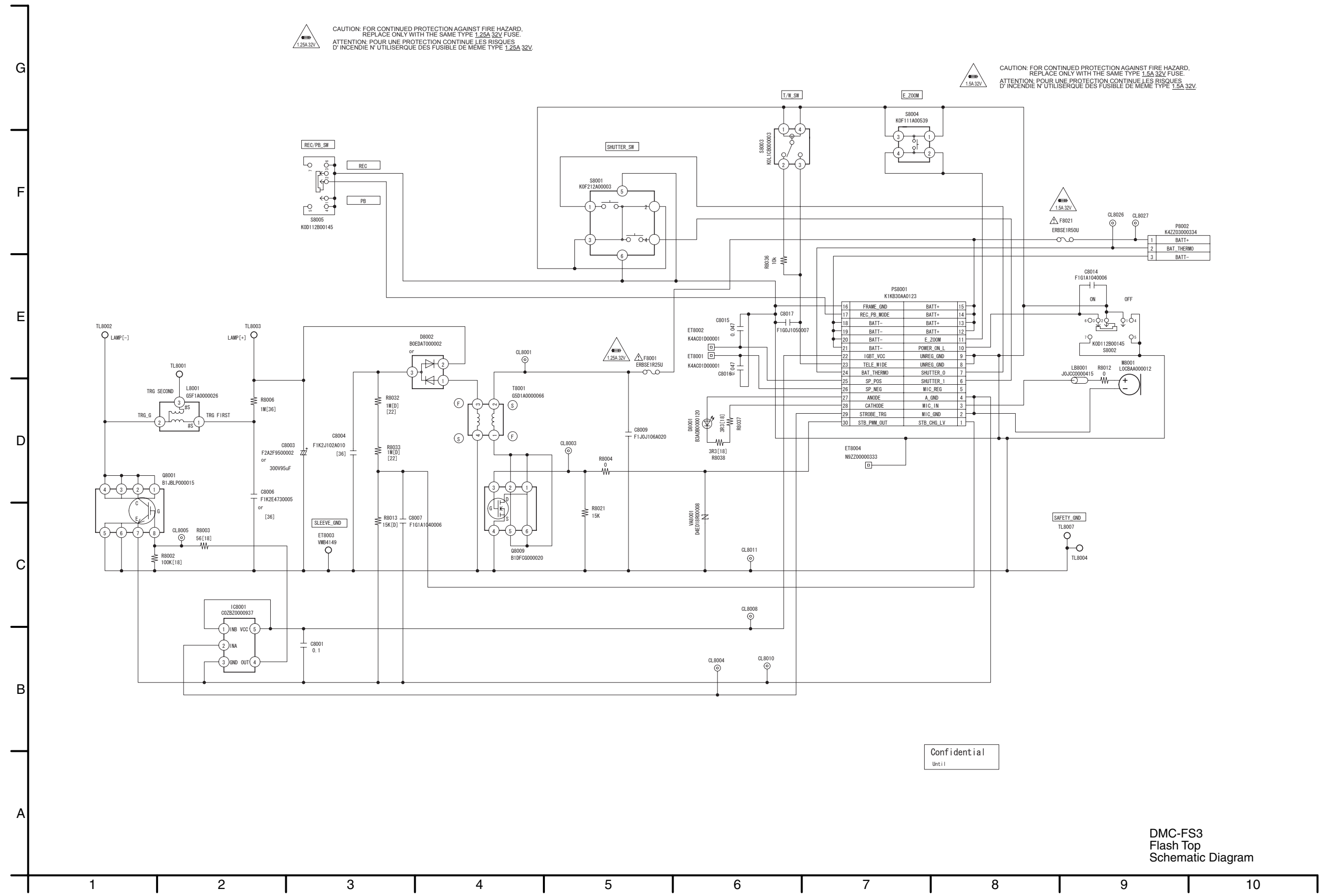

Confidential
 Unt 1

DMC-FS3
 Flash Top
 Schematic Diagram

S4.3. SD Flex Schematic Diagram

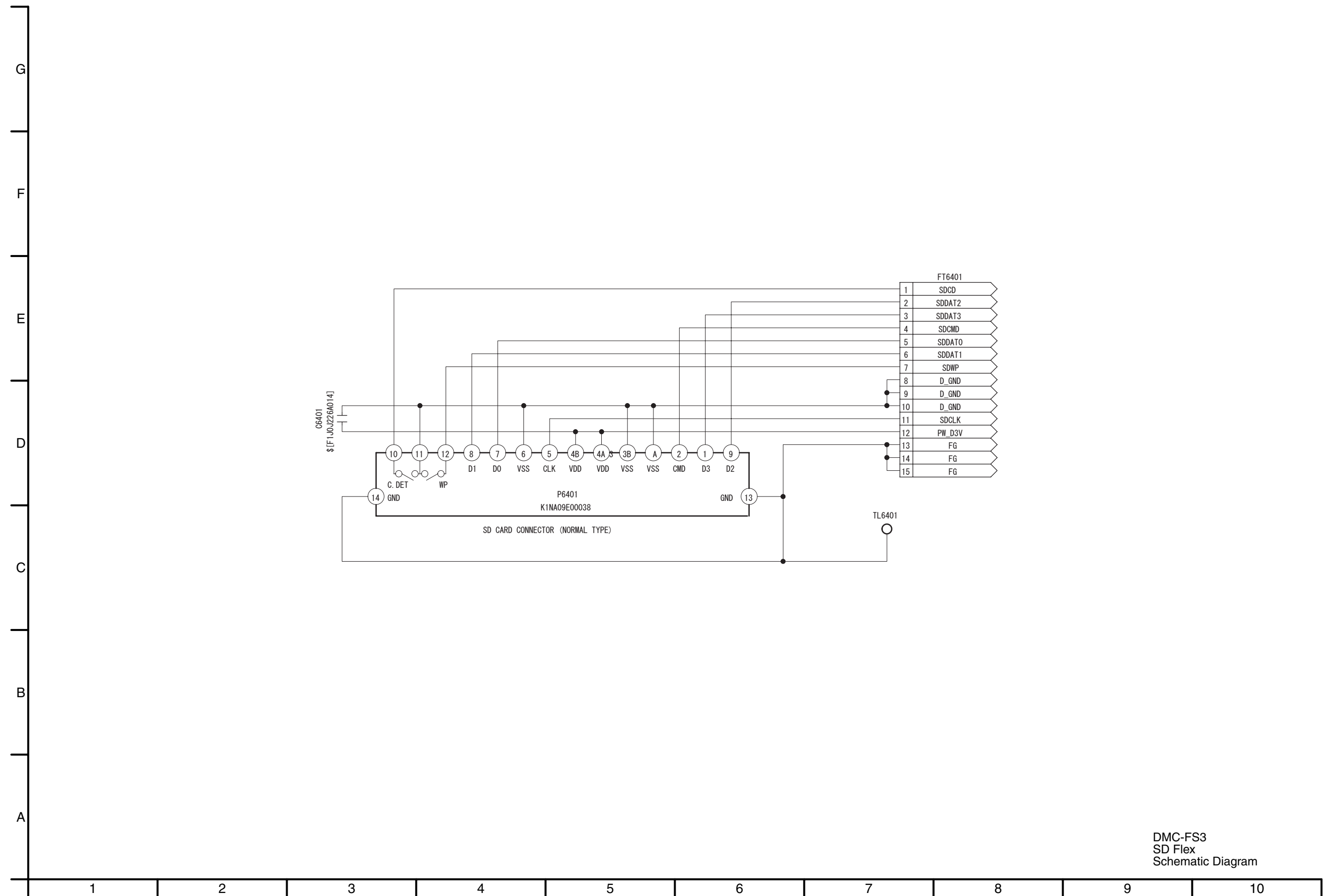

S4.4. CCD Flex Schematic Diagram

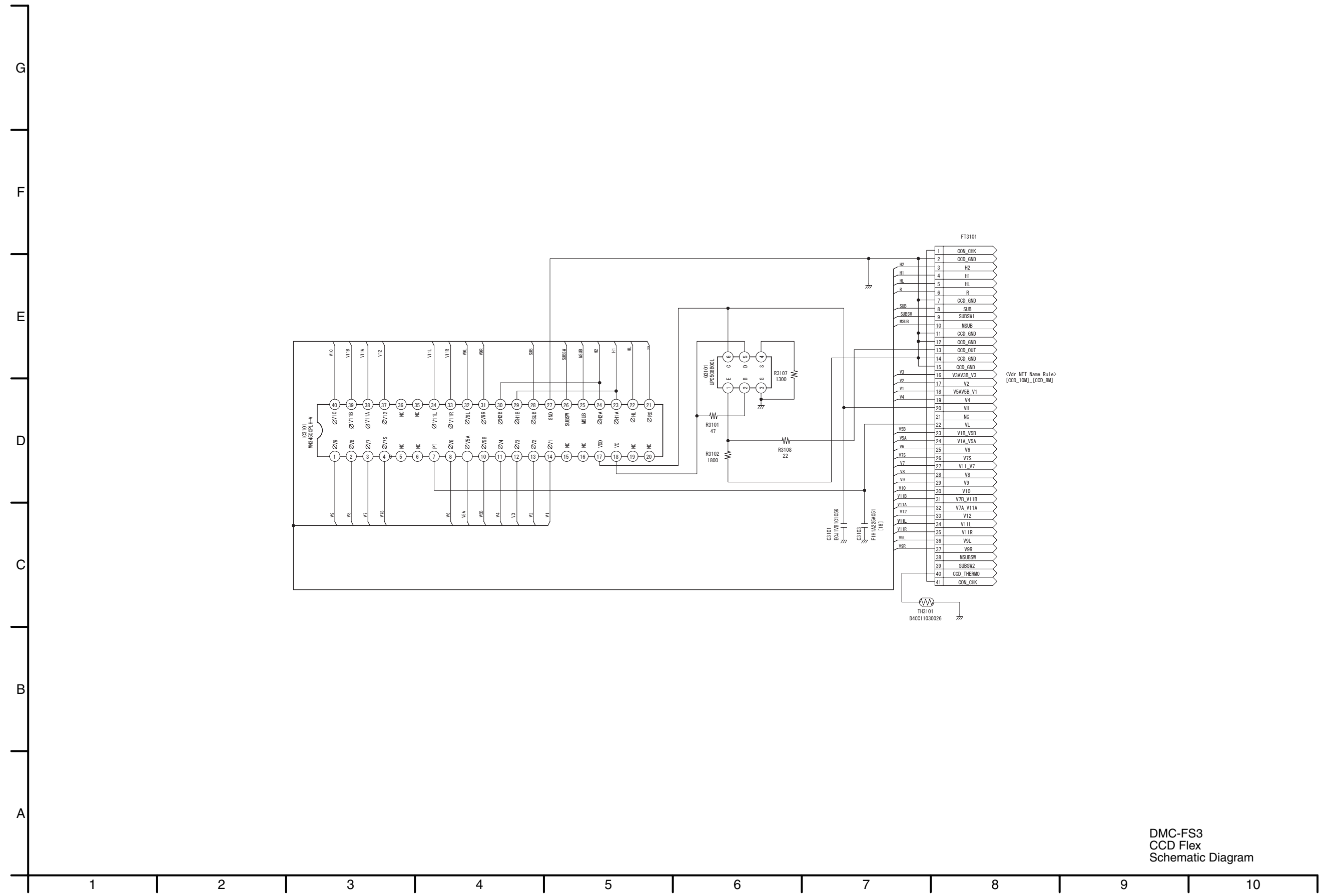

DMC-FS3
CCD Flex
Schematic Diagram

S4.5. Lens Flex Schematic Diagram

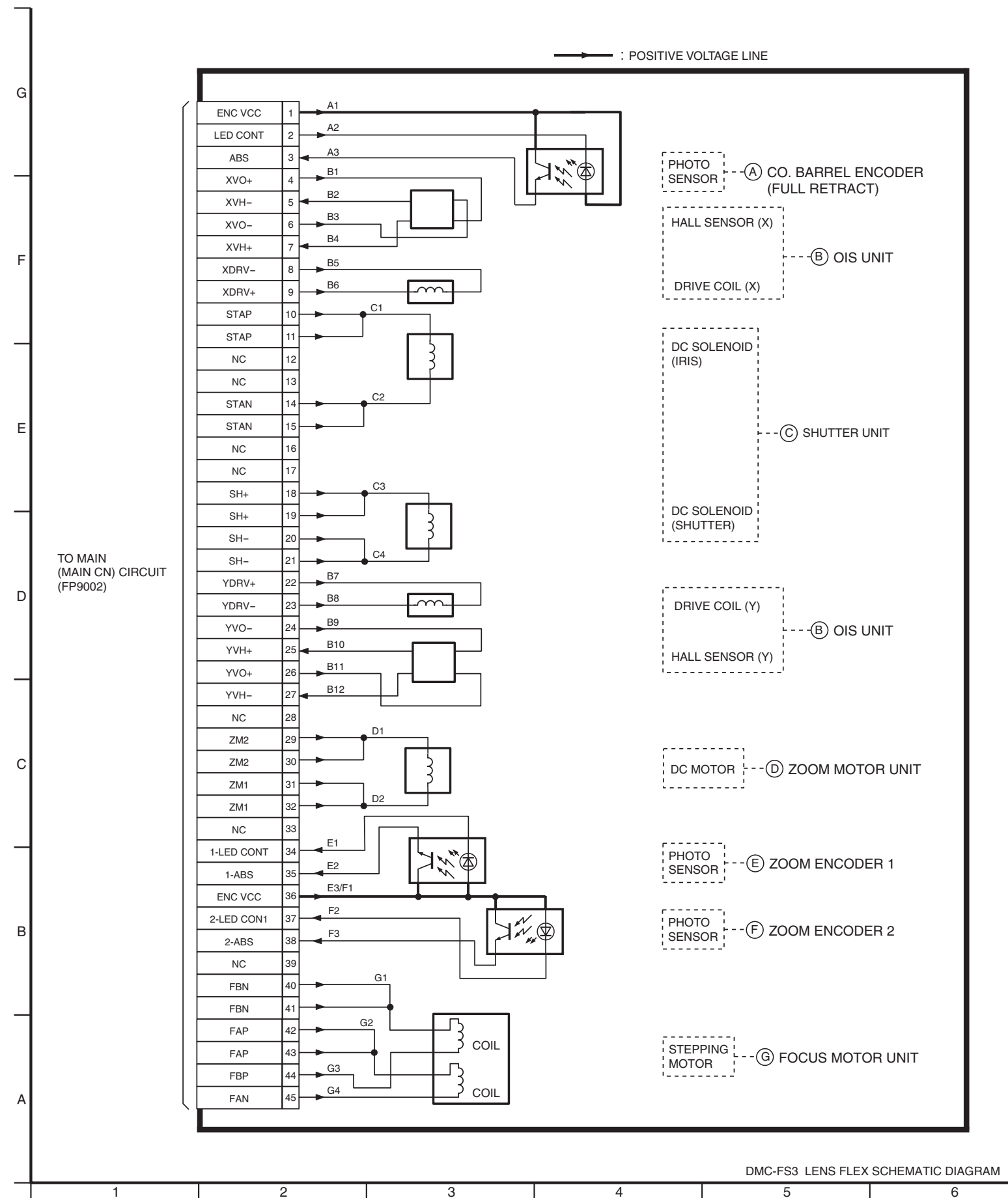

S5. Print Circuit Board

S5.1. Flash Top P.C.B.

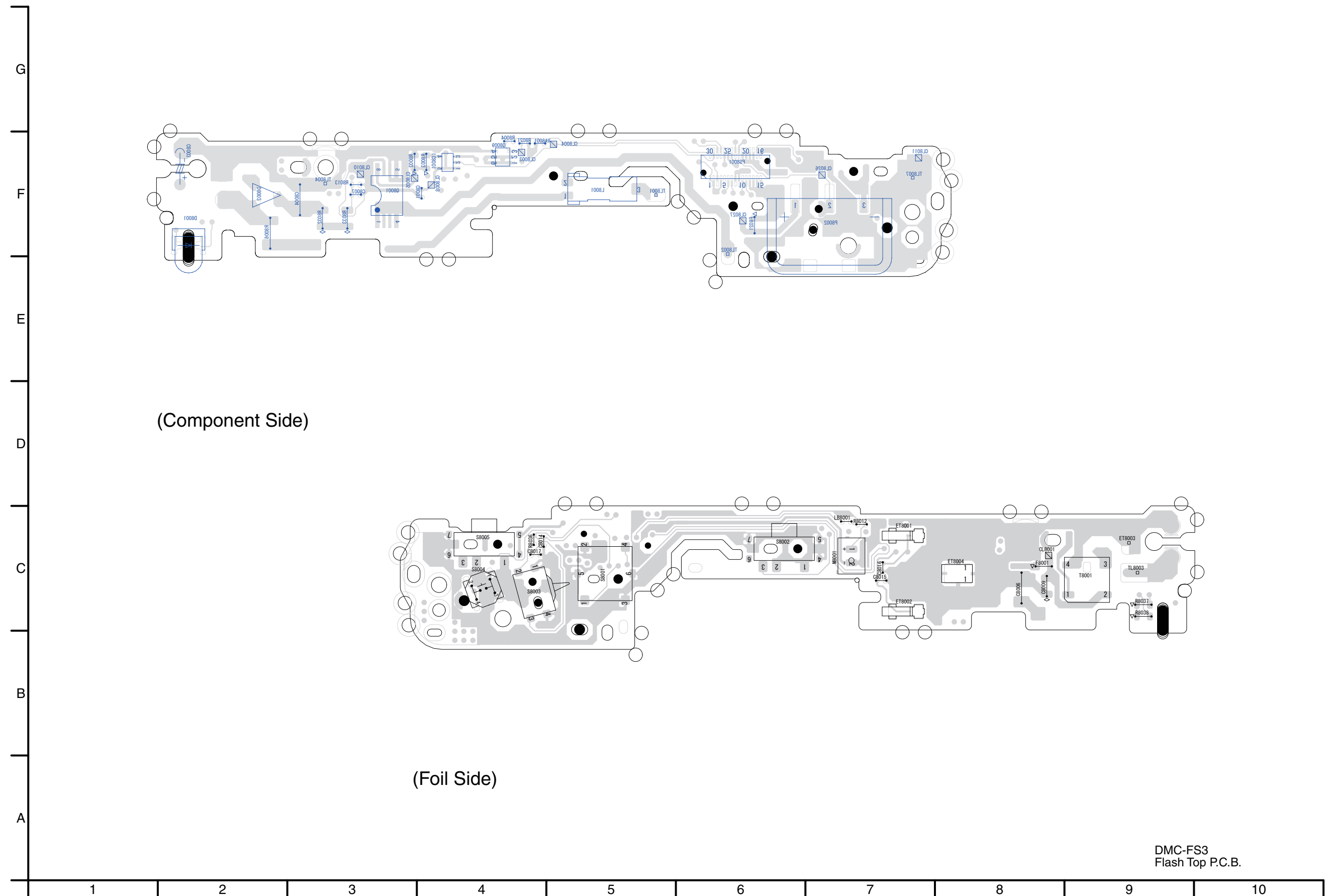

DMC-FS3
Flash Top P.C.B.

S5.2. SD Flex P.C.B. / S5.3. CCD Flex P.C.B.

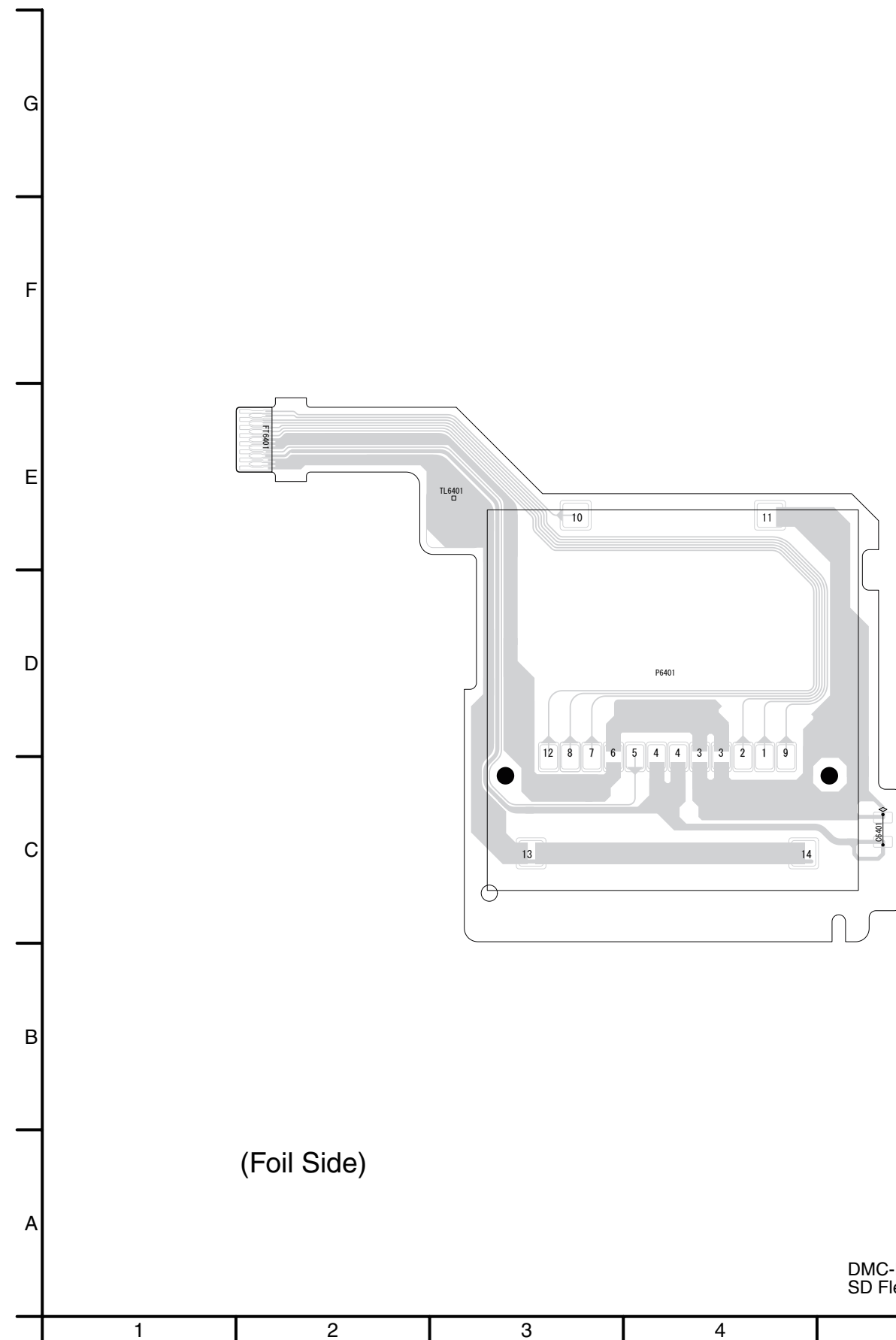

(Foil Side)

DMC-FS3
SD Flex P.C.B.

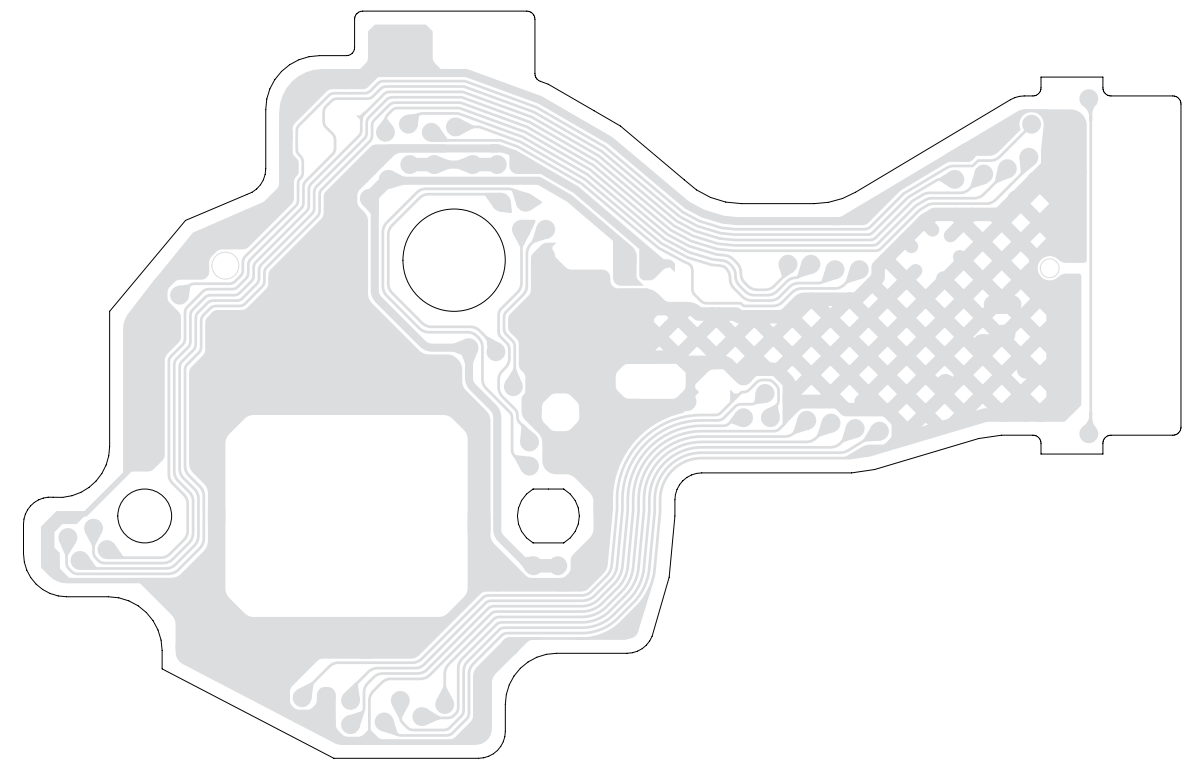

(Component Side)

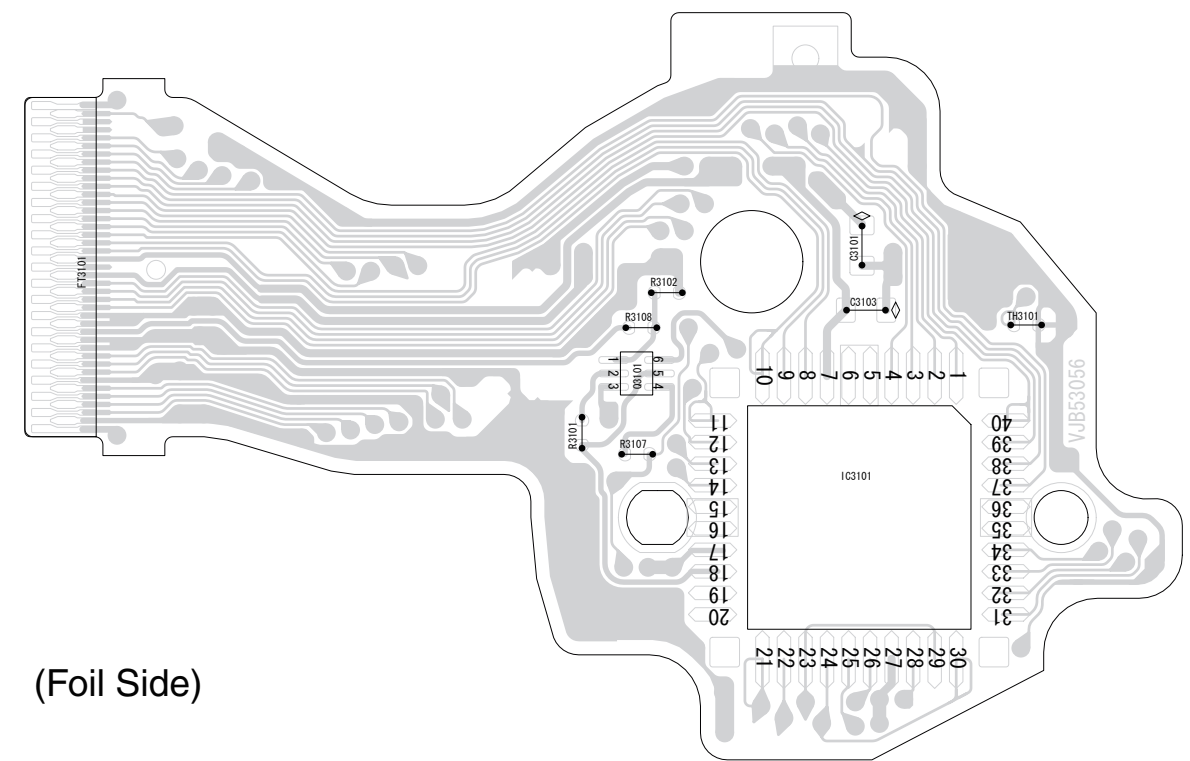

(Foil Side)

DMC-FS3
CCD Flex P.C.B.

S5.4. Lens Flex P.C.B.

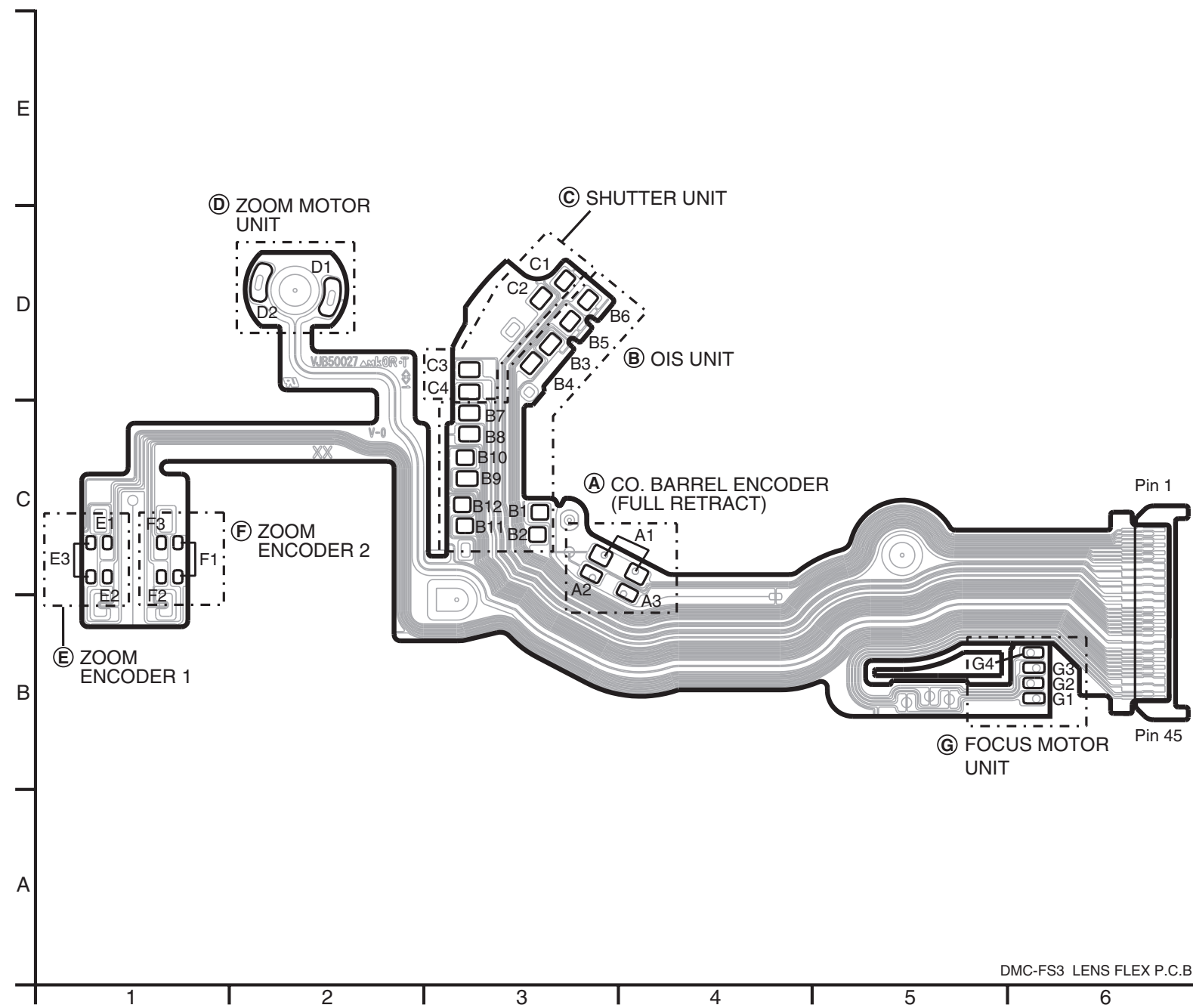

DMC-FS3 LENS FLEX P.C.B.

S6. Replacement Parts List

- Note: 1.* Be sure to make your orders of replacement parts according to this list.
2. IMPORTANT SAFETY NOTICE
Components identified with the mark \triangle have the special characteristics for safety.
When replacing any of these components, use only the same type.
3. Unless otherwise specified,
All resistors are in OHMS, K=1,000 OHMS. All capacitors are in MICRO-FARADS (uf), P=uuF.
4. The marking (RTL) indicates the retention time is limited for this item. After the discontinuation of this assembly in production, it will no longer be available.
5. Supply of CD-ROM, in accordance with license protection, is allowable as replacement parts only for customers who accidentally damaged or lost their own.

E.S.D. standards for Electrostatically Sensitive Devices, refer to PREVENTION OF ELECTROSTATIC DISCHARGE (ESD) TO ELECTROSTATICALLY SENSITIVE (ES) DEVICES section.

Definition of Parts supplier:

1. Parts marked with [MBI] in the remarks column are supplied from **Matsushita Battery Industrial Co., Ltd.**
2. Parts marked with [PAVC-CSG] in the remarks column are supplied from **PAVC COMPANY CS Group (PAVC-CSG).**
Others are supplied from **PAVCSG (ASPC).**

Ref.No.	Part No.	Part Name & Description	Pcs	Remarks
		----- P.C.B. LIST -----		
##	VEP58052A	FLASH TOP P.C.B.	1	(RTL) E.S.D.
##	VEK0L87	CCD UNIT	1	[PAVC-CSG] E.S.D.
		--- INDIVIDUAL PARTS ---		
C8003	F2A2F9500002	E.CAPACITOR	1	
ET8003	VMB4149	EARTH SPRING	1	
		--- ELEC. COMPONENTS ---		

Ref.No.	Part No.	Part Name & Description	Pcs	Remarks

Ref.No.	Part No.	Part Name & Description	Pcs	Remarks	Ref.No.	Part No.	Part Name & Description	Pcs	Remarks
					L8001	G5F1A0000026	CHIP INDUCTOR	1	
					LB8001	J0JCC0000415	FILTER	1	
					M8001	L0CBAA000012	MICROPHONE	1	
					P8002	K4ZZ03000334	BATTERY CATCHER	1	
					PS8001	K1KB30AA0123	CONNECTOR 30P	1	
					Q8001	B1JBLP000015	TRANSISTOR	1	E.S.D.
					Q8009	B1DFCG000020	TRANSISTOR	1	E.S.D.
					R8002	ERJ3GEYJ104V	M.RESISTOR CH 1/10W 100K	1	
					R8003	ERJ3GEYJ560V	M.RESISTOR CH 1/10W 56	1	
					R8004	ERJ2GE0R00X	M.RESISTOR CH 1/16W 0	1	
					R8006	ERJ8GEYJ105V	M.RESISTOR CH 1/8W 1M	1	
					R8012	ERJ2GE0R00X	M.RESISTOR CH 1/16W 0	1	
					R8013	ERJ2RHD153X	M.RESISTOR CH 1/16W 15K	1	
					R8021	ERJ2GEJ153X	M.RESISTOR CH 1/16W 15K	1	
					R8032	ERJ6RED105V	M.RESISTOR CH 1/16W 1M	1	
					R8033	ERJ6RED105V	M.RESISTOR CH 1/16W 1M	1	
					R8036	ERJ2GEJ103X	M.RESISTOR CH 1/16W 10K	1	
					R8037	ERJ3GEYJ3R3V	M.RESISTOR CH 1/10W 3.3	1	
					R8038	ERJ3GEYJ3R3V	M.RESISTOR CH 1/10W 3.3	1	
					S8001	K0F212A00003	SWITCH	1	
					S8002	K0D112B00145	SWITCH	1	
					S8003	K0L1CB000003	SWITCH	1	
					S8004	K0F111A00539	SWITCH	1	
					S8005	K0D112B00145	SWITCH	1	
					T8001	G5D1A0000066	TRANSFORMER	1	
					VA8001	D4ED18R00008	VARISTOR	1	
					##	VEK0L87	CCD UNIT		[PAVC-CSG] E.S.D.
					C3101	ECJ1VB1C105K	C.CAPACITOR CH 16V 1U	1	[PAVC-CSG]
					C3103	F1H1A225A051	C.CAPACITOR CH 10V 2.2U	1	[PAVC-CSG]
					Q3101	UP05C8B00L	TRANSISTOR	1	[PAVC-CSG] E.S.D.
					R3101	ERJ2GEJ470	M.RESISTOR CH 1/16W 47	1	[PAVC-CSG]
					R3102	ERJ2GEJ182	M.RESISTOR CH 1/16W 1.8K	1	[PAVC-CSG]
					R3107	ERJ2GEJ132	M.RESISTOR CH 1/16W 1.3K	1	[PAVC-CSG]
					R3108	ERJ2GEJ220	M.RESISTOR CH 1/16W 22	1	[PAVC-CSG]
					TH3101	D4CC11030026	NTC THERMISTORS	1	[PAVC-CSG]
					##	VEP58052A	FLASH TOP P.C.B.		(RTL) E.S.D.
	C8001	F1G1A1040006	C.CAPACITOR CH 10V 0.1U	1					
	C8004	F1K2J102A010	C.CAPACITOR 630V 1000P	1					
	C8006	F1K2E4730005	C.CAPACITOR 250V 0.047U	1					
	C8007	F1G1A1040006	C.CAPACITOR CH 10V 0.1U	1					
	C8009	F1J0J106A020	C.CAPACITOR CH 6.3V 10U	1					
	C8014	F1G1A1040006	C.CAPACITOR CH 10V 0.1U	1					
	C8015	D4ED18R00008	VARISTOR	1					
	C8016	D4ED18R00008	VARISTOR	1					
	C8017	F1G0J1050007	C.CAPACITOR CH 6.3V 1U	1					
	D8001	B3ADB0000120	AF LED	1					E.S.D.
	D8002	B0EDAT000002	DIODE	1					E.S.D.
	ET8001	K4AC01D00001	EARTH SPRING	1					
	ET8002	K4AC01D00001	EARTH SPRING	1					
	ET8004	N9ZZ00000333	EARTH SPRING	1					
	F8001	ERBSE1R25U	FUSE 32V 1.25A	1					
	F8021	ERBSE1R50U	FUSE 32V 1.5A	1					
	IC8001	C0ZBZ0000937	IC	1					E.S.D.

DMC-FS3P/PC/PL/PR/EB/EE/EF/EG/E/GC/GD/GK/GN/GT/GJ

Ref.No.	Part No.	Part Name & Description	Pcs	Remarks
1	VGO9878	CCD SHEET	1	
2	VEK0L83	SD FPC UNIT	1	
3	VEP56057B	MAIN P.C.B.	1	(RTL) E.S.D.
4	ML421S/ZTE	BUTTON BATTERY	1	(MBIJ)(B9101)
5	VGO9695	PCB SPACER	1	
6	VGO9709	LENS SPACER	1	
7	VKF4254	JACK DOOR	1	(-S)
7	VKF4326	JACK DOOR	1	(-G)
7	VKF4272	JACK DOOR	1	(-P)
7	VKF4274	JACK DOOR	1	(-A)
7	VKF4266	JACK DOOR	1	(-K)
8	VMP8978	FRAME PLATE	1	
9	VMP8984	TRIPOD	1	
10	VMS7864	JACK DOOR SHAFT	1	
11	VYK2J15	FRONT CASE UNIT	1	(-S)
11	VYK2P53	FRONT CASE UNIT	1	(-G)
11	VYK2J24	FRONT CASE UNIT	1	(-P)
11	VYK2J27	FRONT CASE UNIT	1	(-A)
11	VYK2J21	FRONT CASE UNIT	1	(-K)
12	VYK2J18	BATTERY DOOR UNIT	1	(-S)
12	VYK2P55	BATTERY DOOR UNIT	1	(-G)
12	VYK2J26	BATTERY DOOR UNIT	1	(-P)
12	VYK2J29	BATTERY DOOR UNIT	1	(-A)
12	VYK2J23	BATTERY DOOR UNIT	1	(-K)
12-1	VMB4143	BATTERY DOOR SPRING	1	
12-2	VMS7863	BATTERY DOOR SHAFT	1	
13	VGO9717	BATTERY LOCK KNOB	1	
14	VMB4151	BATTERY OUT SPRING	1	
15	VMB4152	BATTERY LOCK SPRING	1	
16	VMP8976	FRAME	1	(-S)(-P)(-A)
16	VMP9102	FRAME	1	(-G)(-K)
17	VYK2J97	BATTERY CASE UNIT	1	
18	VYK2Q73	TOP ORNAMENT UNIT	1	
19	L0AA01A00032	SPEAKER	1	
20	VGL1263	AF PANEL LIGHT	1	
21	VGO9697	POWER KNOB BASE	1	
22	VGO9836	FLASH SHEET	1	
23	VGU0C05	MODE KNOB	1	
24	VGU0C06	E ZOOM BUTTON	1	
25	VGU0C07	POWER KNOB	1	
26	VMP8979	TOP PLATE L	1	
27	VMP8980	TOP PLATE R	1	
28	VMT1905	MIC DAMPER	1	
29	EFN-FSW51ZC	FLASH UNIT	1	
30	F2A2F9500002	E.CAPACITOR	1	(C8003)
31	VEP58052A	FLASH TOP P.C.B.	1	(RTL) E.S.D.
32	VMB4149	EARTH SPRING	1	(ET8003)
33	VYK2J85	REAR CASE UNIT	1	(-S)
33	VYK2P54	REAR CASE UNIT	1	(-G)
33	VYK2J25	REAR CASE UNIT	1	(-P)
33	VYK2J28	REAR CASE UNIT	1	(-A)
33	VYK2J22	REAR CASE UNIT	1	(-K)
33-1	VGL1265	REAR PANEL LIGHT	1	(EXCEPT P,PC,PL)
33-2	VGU0C08	CURSOR BUTTON	1	(EXCEPT P,PC,PL)
34	VYK2J17	LCD UNIT	1	
100	VXW0923	LENS UNIT (W/O CCD)	1	[PAVC-CSG]
101	VDL1950	OPTICAL FILTER	1	[PAVC-CSG]
102	VEK0L87	CCD UNIT	1	[PAVC-CSG]
103	VMX3658	CCD CUSHION	1	[PAVC-CSG]
104	VXP2903	1ST LENS FRAME UNIT	1	[PAVC-CSG]
105	VXP2898	DRIVE/DIRECT FRAME UNIT	1	[PAVC-CSG]
107	VXP2899	FIX FRAME UNIT	1	[PAVC-CSG]
109	L6DA8BEC0003	ZOOM MOTOR	1	[PAVC-CSG]
110	VXP2896	2ND LENS FRAME UNIT	1	[PAVC-CSG]
113	VXP2902	MASTER FLANGE UNIT	1	[PAVC-CSG]
113-1	L6HA66NC0013	FOCUS MOTOR UNIT	1	[PAVC-CSG]
113-2	VMB4173	FOCUS SPRING	1	[PAVC-CSG]
113-3	VXP2900	3RD LENS FRAME UNIT	1	[PAVC-CSG]
114	VEK0L88	LENS FPC UNIT	1	[PAVC-CSG]
114-1	B3NAA0000132	PHOTO SENSOR	1	[PAVC-CSG]
114-2	B3NBA0000011	PHOTO SENSOR S	1	[PAVC-CSG]
114-3	B3NBA0000011	PHOTO SENSOR S	1	[PAVC-CSG]

Ref.No.	Part No.	Part Name & Description	Pcs	Remarks
B1	VHD1998	SCREW	1	
B2	VHD2004	SCREW	1	
B3	VHD2004	SCREW	1	
B4	VHD2002	SCREW	1	(-S)(-G)(-P)(-A)
B4	VHD2005	SCREW	1	(-K)
B5	VHD2002	SCREW	1	(-S)(-G)(-P)(-A)
B5	VHD2005	SCREW	1	(-K)
B6	VHD2002	SCREW	1	(-S)(-G)(-P)(-A)
B6	VHD2005	SCREW	1	(-K)
B7	VHD2002	SCREW	1	(-S)(-G)(-P)(-A)
B7	VHD2005	SCREW	1	(-K)
B8	VHD2002	SCREW	1	(-S)(-G)(-P)(-A)
B8	VHD2005	SCREW	1	(-K)
B9	VHD2002	SCREW	1	(-S)(-G)(-P)(-A)
B9	VHD2005	SCREW	1	(-K)
B10	VHD2003	SCREW	1	(-S)(-G)(-P)(-A)
B10	VHD2006	SCREW	1	(-K)
B11	VHD2003	SCREW	1	(-S)(-G)(-P)(-A)
B11	VHD2006	SCREW	1	(-K)
B12	VHD1998	SCREW	1	
B13	VHD1998	SCREW	1	
B14	VHD2003	SCREW	1	
B15	XQN16+BJ7FN	SCREW	1	
B16	XQN16+BJ7FN	SCREW	1	
B17	XQN16+BJ7FN	SCREW	1	
B100	VHD1871	SCREW	1	[PAVC-CSG]
B101	VHD1871	SCREW	1	[PAVC-CSG]
B102	VHD1871	SCREW	1	[PAVC-CSG]
B103	XQN14+CJ4FN	SCREW	1	[PAVC-CSG]
B104	XQN14+CJ4FN	SCREW	1	[PAVC-CSG]
B105	XQN14+CJ4FN	SCREW	1	[PAVC-CSG]
B106	XQN14+CJ4FN	SCREW	1	[PAVC-CSG]
B107	XQN14+CJ4FN	SCREW	1	[PAVC-CSG]
B108	VHD2020	SCREW	1	[PAVC-CSG]

Ref.No.	Part No.	Part Name & Description	Pcs	Remarks	Ref.No.	Part No.	Part Name & Description	Pcs	Remarks
200	VPF1302	CAMERA BAG	1	P,PC,PL					
⚠ 201	DE-A39BA/SX	BATTERY CHARGER	1	P,PC,PL					
⚠ 202	-----	BATTERY	1	P,PC,PL					
204	K1HA08CD0007	USB CABLE W/PLUG	1	P,PC,PL					
205	K1HA08CD0008	AV CABLE W/PLUG	1	P,PC,PL					
206	VFC4297-A	HAND STRAP	1	P,PC,PL					
207	VFF0400-S	CD-ROM	1	P,PC See "Notes" [PAVC-CSG]					
207	VFF0401-S	CD-ROM	1	PL See "Notes" [PAVC-CSG]					
209	VPF1100	BAG, POLYETHYLENE	1	P,PC,PL					
⚠ 210	VFF0406-C	CD-ROM (INSTRUCTION BOOK)	1	PL					
⚠ 211	VQT1M97	INSTRUCTION BOOK (ENGLISH)	1	P,PC					
⚠ 211	VQT1M98	INSTRUCTION BOOK (SPANISH)	1	P					
⚠ 211	VQT1M99	INSTRUCTION BOOK (CANADIAN FRENCH)	1	PC					
⚠ 211	VQT1N00	SIMPLIFIED O/I (ENGLISH/SPANISH)	1	PL					
⚠ 211	VQT1N01	SIMPLIFIED O/I (PORTUGUESE)	1	PL					
212	VQT1M47	O/I SOFTWARE (ENGLISH/CANADIAN FRENCH)	1	P,PC					
212	VQT1M48	O/I SOFTWARE (ENGLISH/SPANISH/ PORTUGUESE)	1	PL					
213	VYQ3914	BATTERY CARRYING CASE U	1	P,PC,PL					
214	VPK3416	PACKING CASE	1	P-S,PC-S					
214	VPK3566	PACKING CASE	1	P-G					
214	VPK3490	PACKING CASE	1	P-P,PC-P					
214	VPK3493	PACKING CASE	1	P-A,PC-A					
214	VPK3485	PACKING CASE	1	PC-K					
214	VPK3501	PACKING CASE	1	PL-S					
214	VPK3502	PACKING CASE	1	PL-K					
214	VPK3503	PACKING CASE	1	PL-P					
214	VPK3504	PACKING CASE	1	PL-A					
215	VPN6649	CUSHION	1	P,PC,PL					

DMC-FS3P/PC/PL/PR/EB/EE/EF/EG/E/GC/GD/GK/GN/GT/GJ

Ref.No.	Part No.	Part Name & Description	Pcs	Remarks
300	VPF1302	CAMERA BAG	1	(EXCEPT P,PC,PL)
△ 301	DE-A40PA/SX	BATTERY CHARGER	1	PR
△ 301	DE-A40AA/SX	BATTERY CHARGER	1	EB,EF,EG,E,GN
△ 301	DE-A40BA/SX	BATTERY CHARGER	1	EE,GC,GD,GK,GJ
△ 301	DE-A40CA/SX	BATTERY CHARGER	1	GT
△ 302	-----	BATTERY	1	(EXCEPT P,PC,PL)
304	K1HA08CD0007	USB CABLE W/PLUG	1	(EXCEPT P,PC,PL)
305	K1HA08CD0008	AV CABLE W/PLUG	1	(EXCEPT P,PC,PL)
306	VFC4297-A	HAND STRAP	1	(EXCEPT P,PC,PL)
307	VFF0401-S	CD-ROM	1	(EXCEPT P,PC,PL) See "Notes" [PAVC-CSG]
309	VPF1100	BAG, POLYETHYLENE	1	(EXCEPT P,PC,PL)
△ 310	VFF0406-C	CD-ROM (INSTRUCTION BOOK)	1	PR,EG,E,GC
△ 311	VQT1N04	SIMPLIFIED O/I (SPANISH/PORTUGUESE)	1	PR,EG
△ 311	VQT1N09	INSTRUCTION BOOK (ENGLISH)	1	EB
△ 311	VQT1N18	INSTRUCTION BOOK (RUSSIAN)	1	EE
△ 311	VQT1N19	INSTRUCTION BOOK (UKRAINIAN)	1	EE
△ 311	VQT1N08	INSTRUCTION BOOK (FRENCH)	1	EF
△ 311	VQT1N02	SIMPLIFIED O/I (GERMAN/FRENCH)	1	EG
△ 311	VQT1N03	SIMPLIFIED O/I (ITALIAN/DUTCH)	1	EG
△ 311	VQT1N05	SIMPLIFIED O/I (SWEDISH/DANISH)	1	E
△ 311	VQT1N06	SIMPLIFIED O/I (POLISH/CZECH)	1	E
△ 311	VQT1N07	SIMPLIFIED O/I (HUNGARIAN/FINNISH)	1	E
△ 311	VQT1N12	SIMPLIFIED O/I (ENGLISH/ CHINESE (TRADITIONAL))	1	GC
△ 311	VQT1N13	SIMPLIFIED O/I (ARABIC/PERSIAN)	1	GC
△ 311	VQT1N17	INSTRUCTION BOOK (KOREAN)	1	GD
△ 311	VQT1N20	INSTRUCTION BOOK (CHINESE (SIMPLIFIED))	1	GK
△ 311	VQT1N16	INSTRUCTION BOOK (ENGLISH)	1	GN
△ 311	VQT1Q99	INSTRUCTION BOOK (CHINESE (TRADITIONAL))	1	GT
△ 311	VQT1Q75	INSTRUCTION BOOK (THAI)	1	GJ
312	VQT1M49	O/I SOFTWARE (GERMAN/FRENCH/ITALIAN/ DUTCH/SPANISH/ PORTUGUESE)	1	PR,EG
312	VQT1M52	O/I SOFTWARE (ENGLISH)	1	EB,GN
312	VQT1M53	O/I SOFTWARE (RUSSIAN/UKRAINIAN)	1	EE
312	VQT1M51	O/I SOFTWARE (FRENCH)	1	EF
312	VQT1M50	O/I SOFTWARE (SWEDISH/DANISH/POLISH/ CZECH/HUNGARIAN/FINNISH)	1	E
312	VQT1M54	O/I SOFTWARE (ENGLISH/ARABIC/PERSIAN/ CHINESE (TRADITIONAL))	1	GC
312	VQT1M57	O/I SOFTWARE (KOREAN)	1	GD
312	VQT1R29	O/I SOFTWARE (CHINESE (SIMPLIFIED))	1	GK
312	VQT1R28	O/I SOFTWARE (CHINESE (TRADITIONAL))	1	GT
312	VQT1Q76	O/I SOFTWARE (THAI)	1	GJ
313	VYQ3914	BATTERY CARRYING CASE U	1	(EXCEPT P,PC,PL)
314	VPK3417	PACKING CASE	1	EB-S,EE-S,EF-S,EG-S,E-S, GC-S,GD-S,GN-S,GT-S, GJ-S

Ref.No.	Part No.	Part Name & Description	Pcs	Remarks
314	VPK3486	PACKING CASE	1	PR-K,EB-K,EE-K,EF-K,EG-K, E-K,GC-K,GD-K,GN-K,GJ-K
314	VPK3491	PACKING CASE	1	PR-P,EB-P,EE-P,EF-P,EG-P, E-P,GC-P,GN-P,GT-P,GJ-P
314	VPK3494	PACKING CASE	1	PR-A,EB-A,EE-A,EF-A,EG-A, E-A
314	VPK3418	PACKING CASE	1	GK-S
314	VPK3488	PACKING CASE	1	GK-K
315	VPN6663	CUSHION	1	(EXCEPT P,PC,PL)
316	VQL1G34	OPERATION LABEL	1	GT
△ 319	K2CT3CA00004	AC CORD W/PLUG	1	EB,GC
△ 320	K2CQ2CA00006	AC CORD W/PLUG	1	EE,EF,EG,E,GC
△ 320	K2CP2YY00001	AC CORD W/PLUG	1	GJ
△ 321	RJA0078-1X	AC CORD W/PLUG	1	GD
△ 322	K2CA2CA00020	AC CORD W/PLUG	1	GK
△ 322	K2CA2CA00027	AC CORD W/PLUG	1	GT
△ 323	K2CJ2DA00008	AC CORD W/PLUG	1	GN
△ 323	RJA0071-K	AC CORD W/PLUG	1	PR

S7. Exploded View

S7.1. Frame and Casing Section

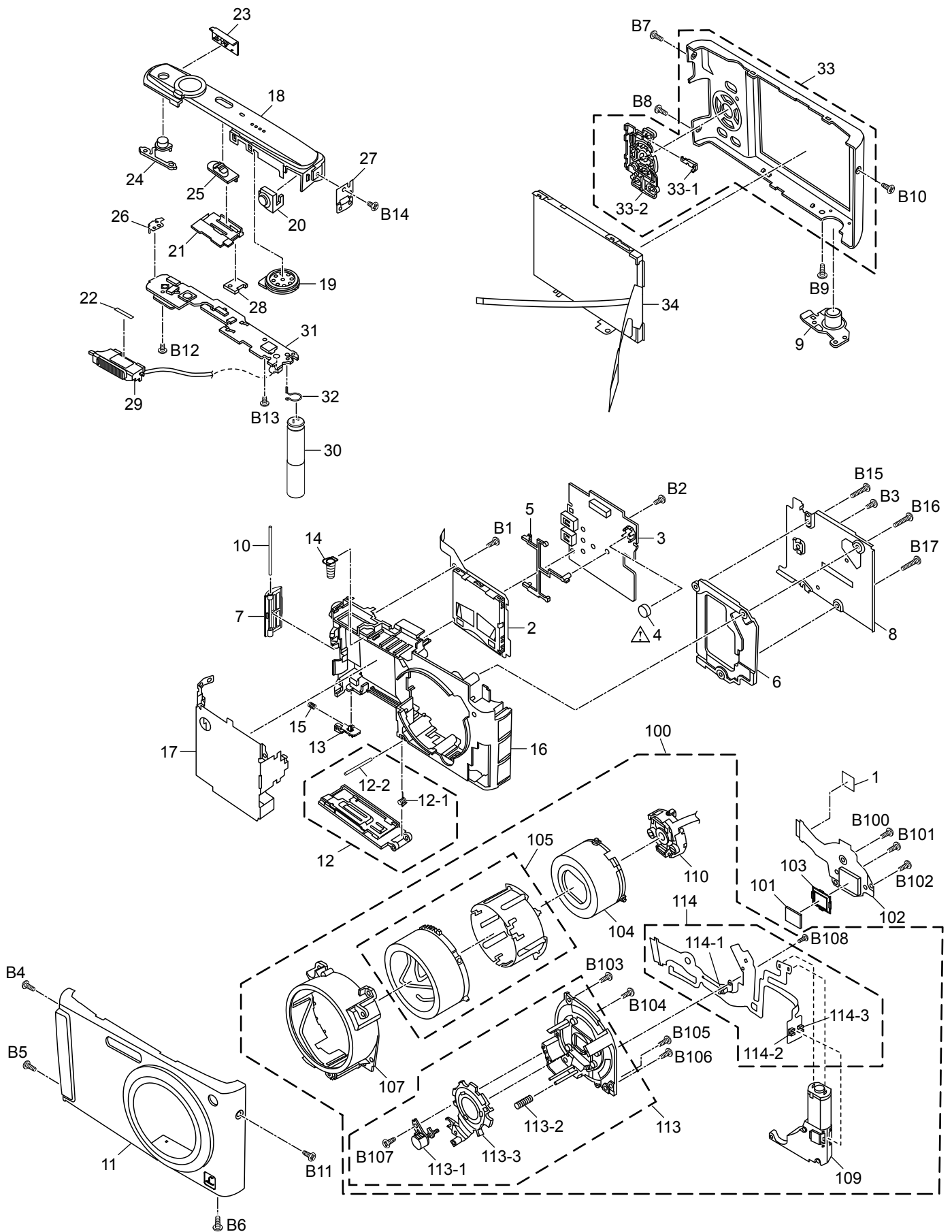

S7.2. Packing Parts and Accessories Section (1)

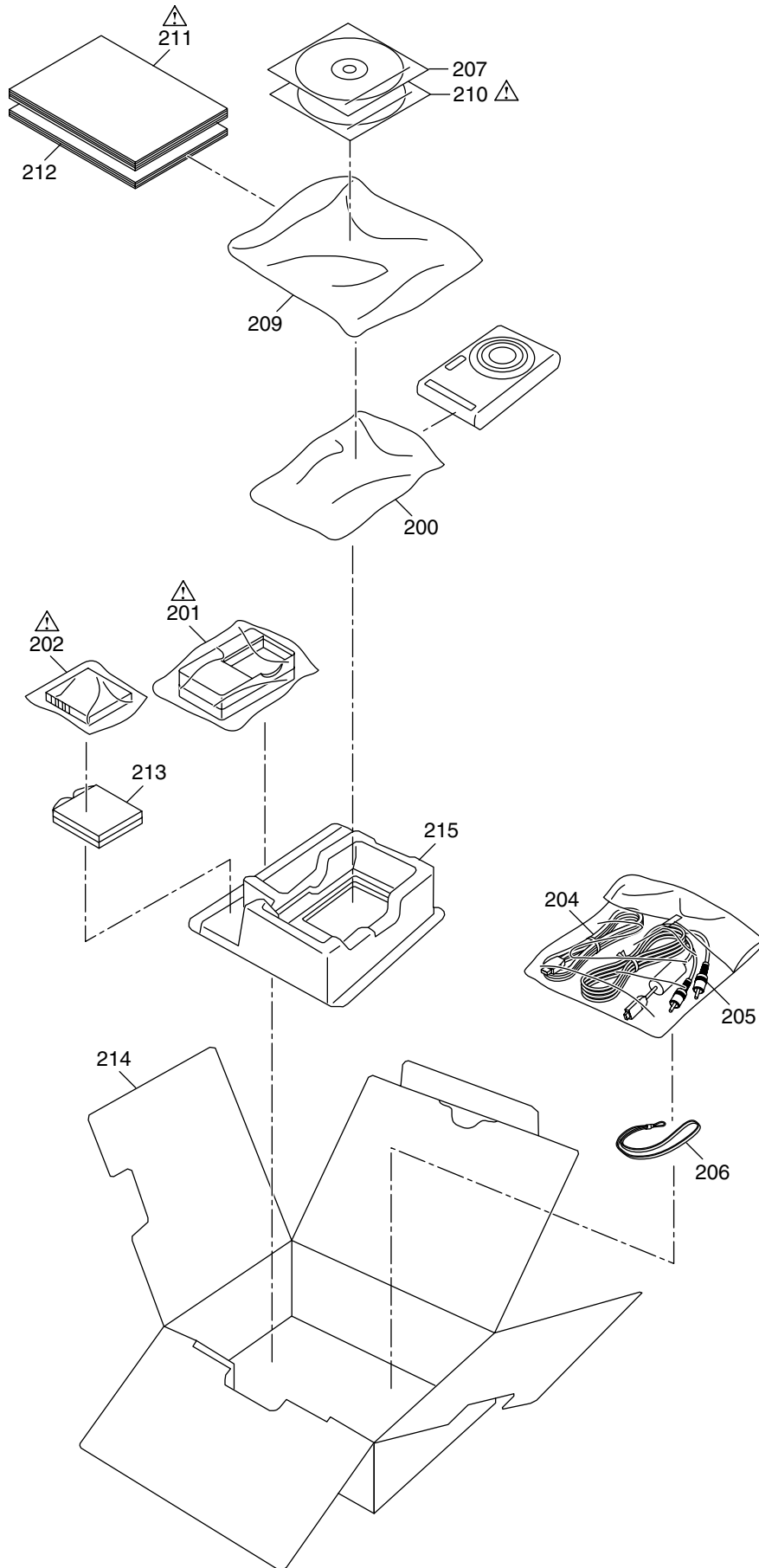

S7.3. Packing Parts and Accessories Section (2)

