

Service Manual

Digital Camera

LUMIX

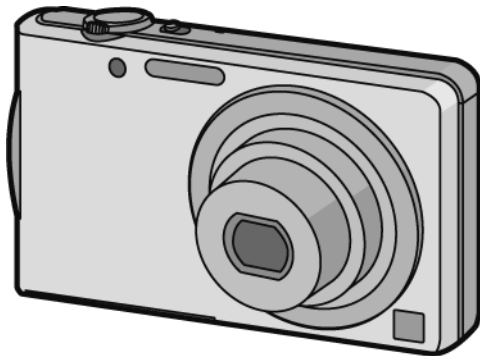

Model No. **DMC-FH5P**

DMC-FH5PC

DMC-FH5PR

DMC-FH5PU

DMC-FH5GA

DMC-FH5GC

DMC-FH5GD

DMC-FH5GF

DMC-FH5GK

DMC-FH5GM

DMC-FH5GN

DMC-FH5GT

DMC-FS18EB

DMC-FS18EE

DMC-FS18EF

DMC-FS18EG

DMC-FS18EP

Vol. 1

Colour

(S).....Silver Type (except PC/PR/GD/GT/EF)

(K).....Black Type

(N).....Gold Type (only P/GK)

(P).....Pink Type (except P/PC/PR/EB/EF/EP)

(V).....Violet Type

(except PR/GA/GC/GD/GF/GM/GT/EP)

Panasonic[®]

© Panasonic Corporation 2011 Unauthorized copying and distribution is a violation of law.

WARNING

This service information is designed for experienced repair technicians only and is not designed for use by the general public. It does not contain warnings or cautions to advise non-technical individuals of potential dangers in attempting to service a product. Products powered by electricity should be serviced or repaired only by experienced professional technicians. Any attempt to service or repair the product or products dealt with in this service information by anyone else could result in serious injury or death.

TABLE OF CONTENTS

	PAGE	PAGE
1 Safety Precautions	3	
1.1. General Guidelines	3	
1.2. Leakage Current Cold Check	3	
1.3. Leakage Current Hot Check (See Figure 1.)	3	
1.4. How to Discharge the E.Capacitor on Flash P.C.B.	4	
2 Warning	5	
2.1. Prevention of Electrostatic Discharge (ESD) to Electrostatically Sensitive (ES) Devices	5	
2.2. How to Recycle the Lithium Ion Battery (U.S. Only)	5	
2.3. Caution for AC Cord(For EB/GC/GM)	6	
2.4. How to Replace the Lithium Battery	7	
3 Service Navigation	8	
3.1. Introduction	8	
3.2. Important Notice (About minimum replacement part size: MAIN P.C.B. & LENS UNIT)	8	
3.3. General Description About Lead Free Solder (PbF)	9	
3.4. Important Notice 1:(Other than U.S.A. and Canadian Market)	9	
3.5. How to Define the Model Suffix (NTSC or PAL model)	10	
4 Specifications	15	
5 Location of Controls and Components	16	
6 Service Mode	18	
6.1. Error Code Memory Function	18	
6.2. ICS (Indication of additional Camera Settings when picture was taken) function	20	
7 Service Fixture & Tools	22	
7.1. Service Fixture and Tools	22	
7.2. When Replacing the Main P.C.B.	22	
8 Disassembly and Assembly Instructions	23	
8.1. Disassembly Flow Chart	23	
8.2. P.C.B. Location	23	
8.3. Disassembly Procedure	24	
8.4. Removal of the CCD Unit	30	
9 Measurements and Adjustments	31	
9.1. Introduction	31	
9.2. Before Disassembling the unit	31	
9.3. Details of Electrical Adjustment	33	
9.4. After Adjustment	37	
10 Maintenance	38	
10.1. Cleaning Lens and LCD Panel	38	

1 Safety Precautions

1.1. General Guidelines

1. IMPORTANT SAFETY NOTICE

There are special components used in this equipment which are important for safety. These parts are marked by

 in the Schematic Diagrams, Circuit Board Layout, Exploded Views and Replacement Parts List. It is essential that these critical parts should be replaced with manufacturer's specified parts to prevent X-RADIATION, shock, fire, or other hazards. Do not modify the original design without permission of manufacturer.

2. An Isolation Transformer should always be used during the servicing of AC Adaptor whose chassis is not isolated from the AC power line. Use a transformer of adequate power rating as this protects the technician from accidents resulting in personal injury from electrical shocks. It will also protect AC Adaptor from being damaged by accidental shorting that may occur during servicing.
3. When servicing, observe the original lead dress. If a short circuit is found, replace all parts which have been overheated or damaged by the short circuit.
4. After servicing, see to it that all the protective devices such as insulation barriers, insulation papers shields are properly installed.
5. After servicing, make the following leakage current checks to prevent the customer from being exposed to shock hazards.

1.2. Leakage Current Cold Check

1. Unplug the AC cord and connect a jumper between the two prongs on the plug.
2. Measure the resistance value, with an ohmmeter, between the jumpered AC plug and each exposed metallic cabinet part on the equipment such as screwheads, connectors, control shafts, etc. When the exposed metallic part has a return path to the chassis, the reading should be between $1\text{ M}\Omega$ and $5.2\text{ M}\Omega$. When the exposed metal does not have a return path to the chassis, the reading must be infinity.

1.3. Leakage Current Hot Check (See Figure 1.)

1. Plug the AC cord directly into the AC outlet. Do not use an isolation transformer for this check.
2. Connect a $1.5\text{ k}\Omega$, 10 W resistor, in parallel with a $0.15\text{ }\mu\text{F}$ capacitor, between each exposed metallic part on the set and a good earth ground, as shown in Figure 1.
3. Use an AC voltmeter, with $1\text{ k}\Omega/\text{V}$ or more sensitivity, to measure the potential across the resistor.
4. Check each exposed metallic part, and measure the voltage at each point.
5. Reverse the AC plug in the AC outlet and repeat each of the above measurements.
6. The potential at any point should not exceed 0.75 V RMS . A leakage current tester (Simpson Model 229 or equivalent) may be used to make the hot checks, leakage current must not exceed $1/2\text{ mA}$. In case a measurement is outside of the limits specified, there is a possibility of a shock hazard, and the equipment should be repaired and rechecked before it is returned to the customer.

Hot-Check Circuit

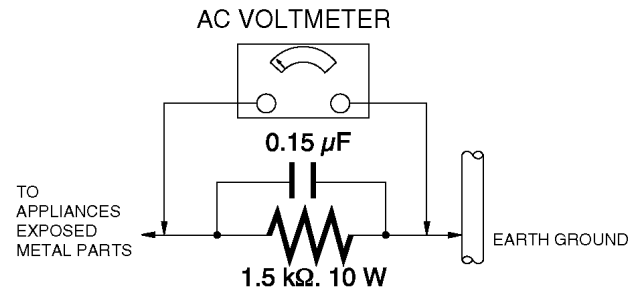

Figure. 1

1.4. How to Discharge the E.Capacitor on Flash P.C.B.

CAUTION:

1. Be sure to discharge the E.capacitor on FLASH P.C.B..
2. Be careful of the high voltage circuit on FLASH P.C.B. when servicing.

[Discharging Procedure]

1. Refer to the disassemble procedure and remove the necessary parts/unit.
2. Install the insulation tube onto the lead part of resistor (ERG5SJ102:1k Ω /5W).
(An equivalent type of resistor may be used.)
3. Place a resistor between both terminals of E.capacitor on the FLASH P.C.B. for approx. 5 seconds.
4. After discharging, confirm that the E.capacitor voltage is lower than 10V by using a voltmeter.

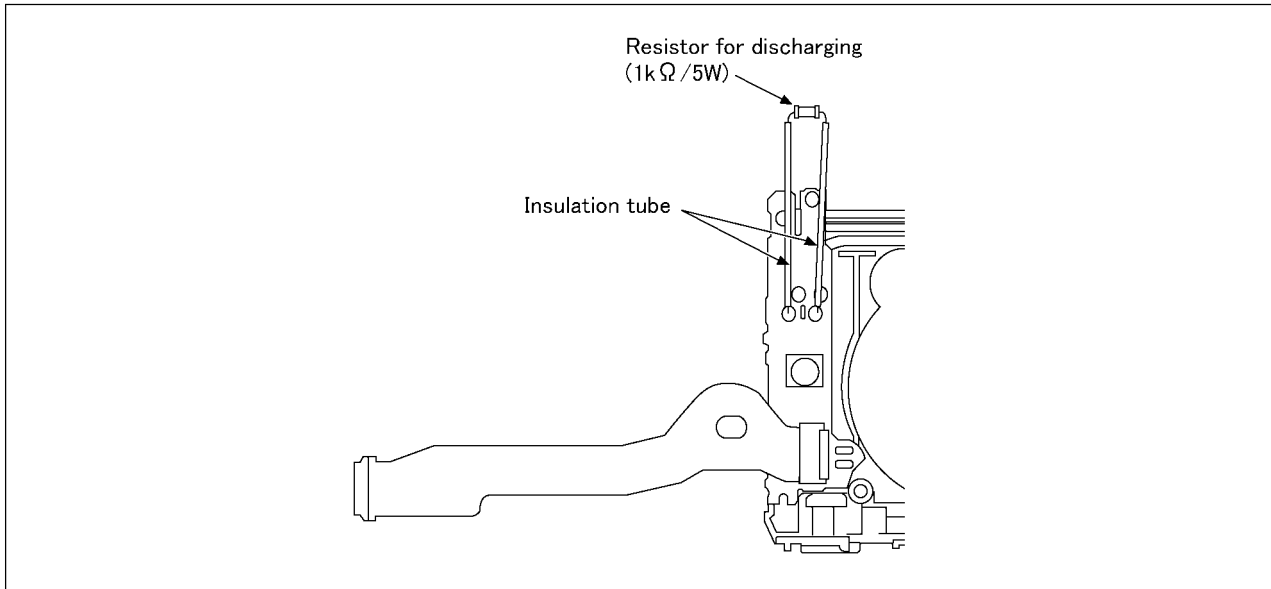

Fig. F1

2 Warning

2.1. Prevention of Electrostatic Discharge (ESD) to Electrostatically Sensitive (ES) Devices

Some semiconductor (solid state) devices can be damaged easily by static electricity. Such components commonly are called Electrostatically Sensitive (ES) Devices.

Examples of typical ES devices are IC (integrated circuits) and some field-effect transistors and semiconductor "chip" components.

The following techniques should be used to help reduce the incidence of component damage caused by electrostatic discharge (ESD).

1. Immediately before handling any semiconductor component or semiconductor-equipped assembly, drain off any ESD on your body by touching a known earth ground. Alternatively, obtain and wear a commercially available discharging ESD wrist strap, which should be removed for potential shock reasons prior to applying power to the unit under test.
2. After removing an electrical assembly equipped with ES devices, place the assembly on a conductive surface such as aluminum foil, to prevent electrostatic charge buildup or exposure of the assembly.
3. Use only a grounded-tip soldering iron to solder or unsolder ES devices.
4. Use only an antistatic solder removal device. Some solder removal devices not classified as "antistatic (ESD protected)" can generate electrical charge sufficient to damage ES devices.
5. Do not use freon-propelled chemicals. These can generate electrical charges sufficient to damage ES devices.
6. Do not remove a replacement ES device from its protective package until immediately before you are ready to install it. (Most replacement ES devices are packaged with leads electrically shorted together by conductive foam, aluminum foil or comparable conductive material).
7. Immediately before removing the protective material from the leads of a replacement ES device, touch the protective material to the chassis or circuit assembly into which the device will be installed.

CAUTION :

Be sure no power is applied to the chassis or circuit, and observe all other safety precautions.

8. Minimize bodily motions when handling unpackaged replacement ES devices. (Otherwise harmless motion such as the brushing together of your clothes fabric or the lifting of your foot from a carpeted floor can generate static electricity (ESD) sufficient to damage an ES device).

2.2. How to Recycle the Lithium Ion Battery (U.S. Only)

ENGLISH



A lithium ion battery that is recyclable powers the product you have purchased. Please call 1-800-8-BATTERY for information on how to recycle this battery.

FRANÇAIS



L'appareil que vous vous êtes procuré est alimenté par une batterie au lithium-ion recyclable. Pour des renseignements sur le recyclage de la batterie, veuillez composer le 1-800-8-BATTERY.

2.3. Caution for AC Cord (For EB/GC/GM)

2.3.1. Information for Your Safety

IMPORTANT

Your attention is drawn to the fact that recording of pre-recorded tapes or discs or other published or broadcast material may infringe copyright laws.

WARNING

To reduce the risk of fire or shock hazard, do not expose this equipment to rain or moisture.

CAUTION

To reduce the risk of fire or shock hazard and annoying interference, use the recommended accessories only.

FOR YOUR SAFETY

DO NOT REMOVE THE OUTER COVER

To prevent electric shock, do not remove the cover. No user serviceable parts inside. Refer servicing to qualified service personnel.

2.3.2. Caution for AC Mains Lead

For your safety, please read the following text carefully.

This appliance is supplied with a moulded three-pin mains plug for your safety and convenience.

A 5-ampere fuse is fitted in this plug.

Should the fuse need to be replaced please ensure that the replacement fuse has a rating of 5 amperes and it is approved by ASTA or BSI to BS1362

Check for the ASTA mark or the BSI mark on the body of the fuse.



If the plug contains a removable fuse cover you must ensure that it is refitted when the fuse is replaced.

If you lose the fuse cover, the plug must not be used until a replacement cover is obtained.

A replacement fuse cover can be purchased from your local Panasonic Dealer.

If the fitted moulded plug is unsuitable for the socket outlet in your home then the fuse should be removed and the plug cut off and disposed of safely.

There is a danger of severe electrical shock if the cut off plug is inserted into any 13-ampere socket.

If a new plug is to be fitted please observe the wiring code as shown below.

If in any doubt, please consult a qualified electrician.

2.3.2.1. Important

The wires in this mains lead are coloured in accordance with the following code:

Blue	Neutral
Brown	Live

As the colours of the wires in the mains lead of this appliance may not correspond with the coloured markings identifying the terminals in your plug, proceed as follows:

The wire which is coloured BLUE must be connected to the terminal in the plug which is marked with the letter N or coloured BLACK.

The wire which is coloured BROWN must be connected to the terminal in the plug which is marked with the letter L or coloured RED.

Under no circumstances should either of these wires be connected to the earth terminal of the three pin plug, marked with the letter E or the Earth Symbol.



2.3.2.2. Before Use

Remove the Connector Cover as follows.

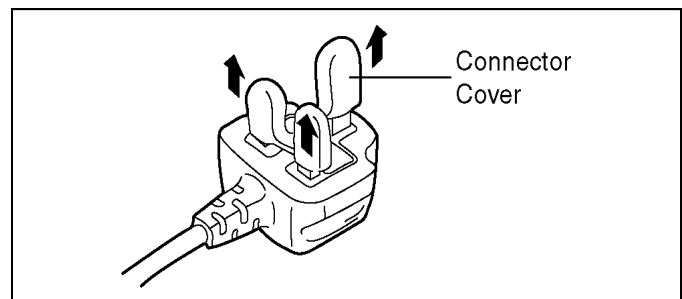

2.3.2.3. How to Replace the Fuse

1. Remove the Fuse Cover with a screwdriver.

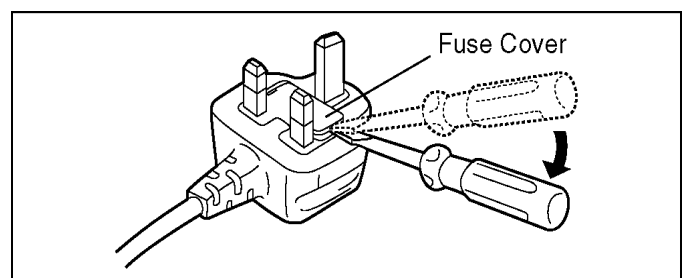

2. Replace the fuse and attach the Fuse cover.

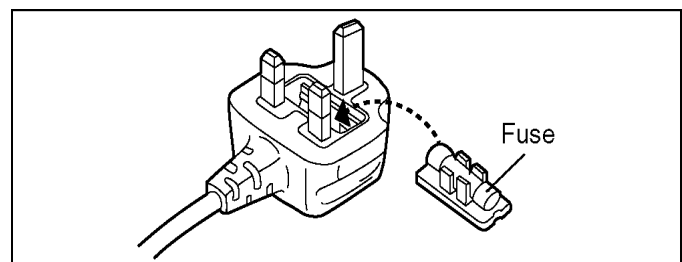

2.4. How to Replace the Lithium Battery

2.4.1. Replacement Procedure

1. Remove the TOP P.C.B.. (Refer to Disassembly Procedures.)
2. Unsolder the each soldering point of electric lead terminal for Lithium battery (Ref. No. "B6301" at foil side of TOP P.C.B.) and remove the Lithium battery together with electric lead terminal. Then replace it into new one.

NOTE:

The Type No. ML421 includes electric lead terminals.

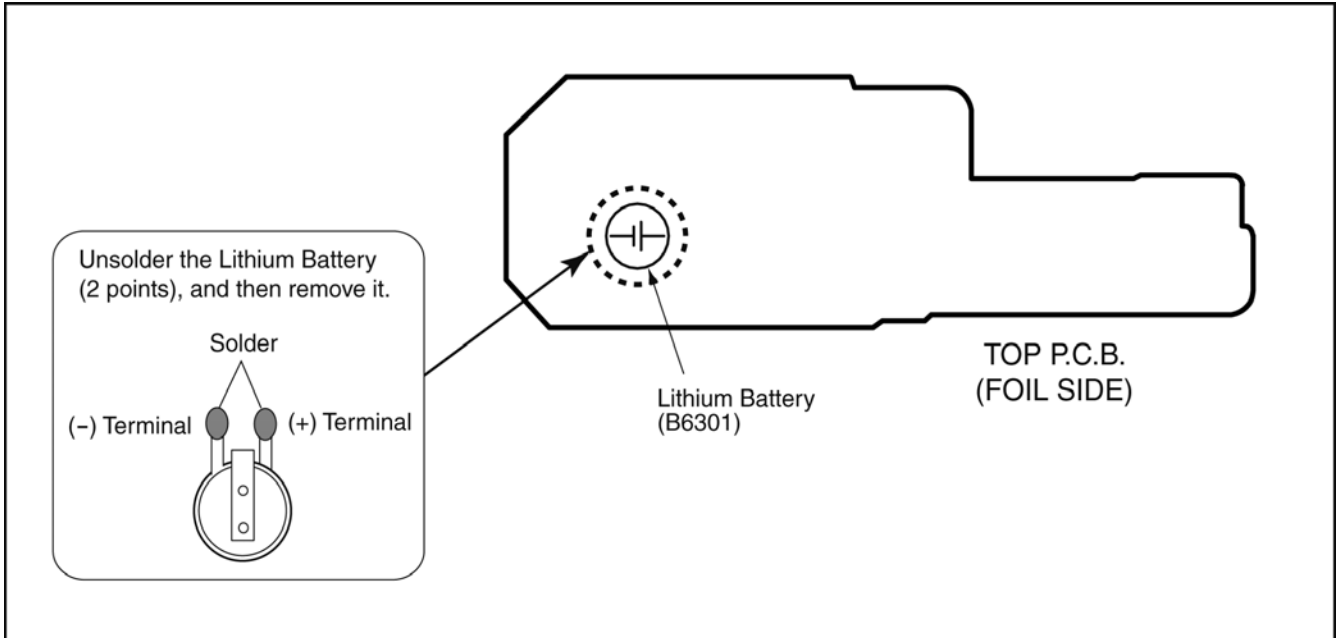

NOTE:

This Lithium battery is a critical component.

(Type No.: ML421 **Manufactured by Energy Company, Panasonic Corporation.**)

It must never be subjected to excessive heat or discharge.

It must therefore only be fitted in requirement designed specifically for its use.

Replacement batteries must be of same type and manufacture.

They must be fitted in the same manner and location as the original battery, with the correct polarity contacts observed.

Do not attempt to re-charge the old battery or re-use it for any other purpose.

It should be disposed of in waste products destined for burial rather than incineration.

(For English)

CAUTION

Danger of explosion if battery is incorrectly replaced.

Replace only with the same or equivalent type recommended by the manufacturer.

Dispose of used batteries according to the manufacturer's instructions.

(For German)

ACHTUNG

Explosionsgefahr bei falschem Anbringen der Batterie. Ersetzen Sie nur mit einem äquivalentem vom Hersteller empfohlenem Typ.

Behandeln Sie gebrauchte Batterien nach den Anweisungen des Herstellers.

(For French)

MISE EN GARDE

Une batterie de remplacement inappropriée peut exploser. Ne remplacez qu'avec une batterie identique ou d'un type recommandé par le fabricant. L'élimination des batteries usées doit être faite conformément aux instructions du fabricant.

NOTE:

Above caution is applicable for a battery pack which is for DMC-FH5/FS18 series, as well.

3 Service Navigation

3.1. Introduction

This service manual contains technical information, which allow service personnel's to understand and service this model.

Please place orders using the parts list and not the drawing reference numbers.

If the circuit is changed or modified, the information will be followed by service manual to be controlled with original service manual.

3.2. Important Notice (About minimum replacement part size: MAIN P.C.B. & LENS UNIT)

3.2.1. MAIN P.C.B.:

1. The MAIN P.C.B. is handled as the smallest replacement part for this unit.

Therefore if any component on the MAIN P.C.B. is/are defective, replace whole MAIN P.C.B. as a unit.

WHICH P.C.B. IS DEFECTIVE? (MAIN P.C.B. or TOP P.C.B.):

The MAIN P.C.B. and TOP P.C.B. are directly connected with solder, without connector.

The TOP P.C.B. consists of the following component part(s). (All of the signal lines are analogue.)

- *.Power button
- *.Shutter button
- *.Self-timer indicator /AF assist lamp
- *.Back-up battery

When inspecting which PCB is defective, use the "Check terminals" and confirm the each signal.
(From RL6301 to RL6312)

Check Terminals

(From RL6301 to RL6312).

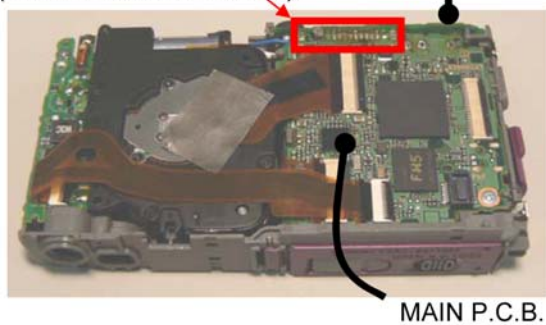

Terminal No.	Terminal Name	Description
RL6301	D_GND	GND
RL6302	tokei	Back-up battery
RL6303	TELE_WIDE	Zoom lever (TELE:Low)
RL6304	SHUTTER_1	Shutter release (ON:Low)
RL6305	SHUTTER_0	Half-shutter (ON:Low)
RL6306	AF3R4V	Anode for Self-timer LED
RL6307	CATHODE	Cathode for Self-timer LED
RL6308	POWER_ON_L	Power button (ON:Low)
RL6309	MIC_GND	Microphone (-)
RL6310	MIC_IN	Microphone (+)
RL6312	D_GND	GND

3.2.2. LENS UNIT:

1. The minimum replacement part size of the Lens part is as shown below.

When servicing, replace the following numbered replacement part size as the smallest size.

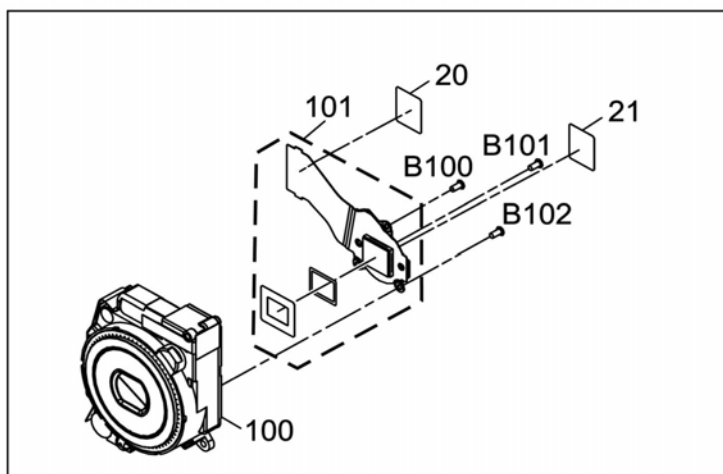

3.2.3. About Flexible Cable and Connector

Do not touch carelessly so that the foreign body should not adhere to the terminal part of flexible cable and connector.

Wipe off with a clean cloth and the cotton bud, etc. when the terminal part is dirty.

3.3. General Description About Lead Free Solder (PbF)

The lead free solder has been used in the mounting process of all electrical components on the printed circuit boards used for this equipment in considering the globally environmental conservation.

The normal solder is the alloy of tin (Sn) and lead (Pb). On the other hand, the lead free solder is the alloy mainly consists of tin (Sn), silver (Ag) and Copper (Cu), and the melting point of the lead free solder is higher approx.30°C (86°F) more than that of the normal solder.

Distinction of P.C.B. Lead Free Solder being used

The letter of "PbF" is printed either foil side or components side on the P.C.B. using the lead free solder.(See right figure)	PbF
--	-----

Service caution for repair work using Lead Free Solder (PbF)

- The lead free solder has to be used when repairing the equipment for which the lead free solder is used.
(Definition: The letter of "PbF" is printed on the P.C.B. using the lead free solder.)
- To put lead free solder, it should be well molten and mixed with the original lead free solder.
- Remove the remaining lead free solder on the P.C.B. cleanly for soldering of the new IC.
- Since the melting point of the lead free solder is higher than that of the normal lead solder, it takes the longer time to melt the lead free solder.
- Use the soldering iron (more than 70W) equipped with the temperature control after setting the temperature at 350±30°C (662±86°F).

Recommended Lead Free Solder (Service Parts Route.)

- The following 3 types of lead free solder are available through the service parts route.
RFKZ03D01KS------(0.3mm 100g Reel)
RFKZ06D01KS------(0.6mm 100g Reel)
RFKZ10D01KS------(1.0mm 100g Reel)

Note

* Ingredient: tin (Sn) 96.5%, silver (Ag) 3.0%, Copper (Cu) 0.5%, Cobalt (Co) / Germanium (Ge) 0.1 to 0.3%

3.4. Important Notice 1:(Other than U.S.A. and Canadian Market)

1. The service manual does not contain the following information because of issues servicing to component level without necessary equipment/facilities.
 - a. Schematic diagram, Block Diagram and P.C.B. layout of MAIN P.C.B. and SUB OPERATION P.C.B..
 - b. Parts list for individual parts for MAIN P.C.B. and SUB OPERATION P.C.B..When a part replacement is required for repairing MAIN P.C.B. and/or SUB OPERATION P.C.B., replace as an assembled parts. (MAIN P.C.B. / SUB OPERATION P.C.B.)
2. The following category is/are recycle module part. Please send it/them to Central Repair Center.
 - MAIN P.C.B. (VEP56127A)
 - SUB OPERATION P.C.B. (VEP50081A)

3.5. How to Define the Model Suffix (NTSC or PAL model)









There are nine kinds of DMC-FH5 and DMC-FS18, regardless of the colours.

- a) DMC-FH5 (Japan domestic model)
- b) DMC-FH5P/PC
- c) DMC-FS18EB/EF/EG/EP
- d) DMC-FS18EE
- e) DMC-FH5GK
- f) DMC-FH5GT
- g) DMC-FH5GD
- h) DMC-FH5GN
- i) DMC-FH5PU/PR/GA/GC/GF/GM

What is the difference is that the "INITIAL SETTINGS" data which is stored in Flash-ROM mounted on MAIN P.C.B..

3.5.1. Defining methods:

To define the model suffix to be serviced, refer to the nameplate which is putted on the bottom side of the Unit.

<p>a) DMC-FH5 (Japan domestic model) The nameplate for this model shows the following Safety registration mark.</p> 
<p>b) DMC-FH5P/PC The nameplate for these models show the following Safety registration mark.</p> 
<p>c) DMC-FS18EB/EF/EG/EP The nameplate for these models show the following Safety registration mark.</p> 
<p>d) DMC-FS18EE The nameplate for this model shows the following Safety registration mark.</p> 
<p>e) DMC-FH5GK The nameplate for this model shows the following Safety registration mark.</p> 
<p>f) DMC-FH5GT The nameplate for this model shows the following Safety registration mark.</p> 
<p>g) DMC-FH5GD The nameplate for this model shows the following Safety registration mark.</p> 
<p>h) DMC-FH5GN The nameplate for this model shows the following Safety registration mark.</p> 
<p>i) DMC-FH5PU/PR/GA/GC/GF/GM The nameplate for these models do not show any above Safety registration mark.</p>

NOTE:

After replacing the MAIN P.C.B., be sure to achieve adjustment.

The service software is available at "TSN Website". To download, click on "Support Information from NWBG/VDBG-AVC".

3.5.2. INITIAL SETTINGS:

After replacing the MAIN P.C.B., make sure to perform the initial settings after achieving the adjustment by ordering the following procedure in accordance with model suffix of the unit.

1. IMPORTANT NOTICE:

Before proceeding Initial settings, make sure to read the following CAUTIONS.

CAUTION 1:(INITIAL SETTINGS)

---AFTER REPLACING THE MAIN P.C.B. ---

*.The model suffix can be chosen JUST ONE TIME.

*.Once one of the model suffix has been chosen, the model suffix lists will not be displayed, thus, it can not be changed.

CAUTION 2:(Stored picture image data in the unit)

This unit employs "Built-in Memory" for picture image data recording. (Approx. 70 MB)

After proceeding "INITIAL SETTINGS", the picture image data stored in the unit is erased.

2. PROCEDURES:

• Precautions: Read the above "CAUTION 1" and "CAUTION 2", carefully.

• Preparation:

- Attach the Battery or AC Adaptor with a DC coupler to the unit.

(Since this unit has built-in memory, it can be performed without inserting SD memory card.)

1. Turn the Power on.

2. Press the [MODE] button, and select the [NORMAL PICTURE] mode by Cursor buttons, then press the [MENU/SET] button.

3. Turn the Power off.

(If the unit is other than [NORMAL PICTURE] mode, it does not display the initial settings menu.)

• **Step 1. The temporary cancellation of "INITIAL SETTINGS":**

Set the [REC]/[PLAYBACK] selector switch to "[REC] (Camera mark)".

While pressing "[UP] of Cursor button" and [W] of Zoom lever simultaneously, turn the Power on.

• **Step 2. The cancellation of "INITIAL SETTINGS":**

Set the [REC]/[PLAYBACK] selector switch to "[PLAYBACK]".

Press "[UP] of Cursor button" and [DISP.] button simultaneously, then turn the Power off.

The LCD displays the " ! " mark before the unit powers down.



• **Step 3. Turn the Power on:**

Set the [REC]/[PLAYBACK] selector switch to "[REC] (Camera mark)", and then turn the Power on.

• **Step 4. Display the INITIAL SETTING:**

While pressing [MENU/SET] button and "[RIGHT] of Cursor button" simultaneously, turn the Power off.

The "INITIAL SETTINGS" menu is displayed.

There are two kinds of "INITIAL SETTINGS" menu form as follows:

[CASE 1. After replacing MAIN P.C.B.]

When MAIN P.C.B. has just been replaced, all of the model suffix is displayed as follows. (Five pages in total)

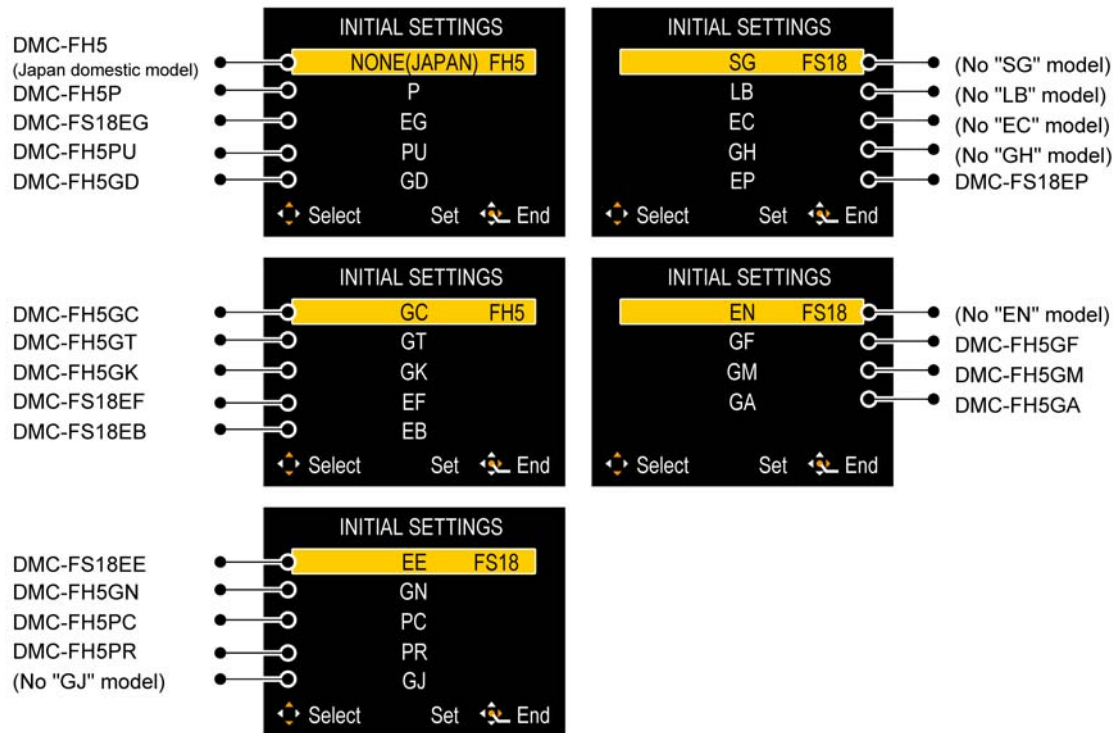

[CASE 2. Other than "After replacing MAIN P.C.B."]

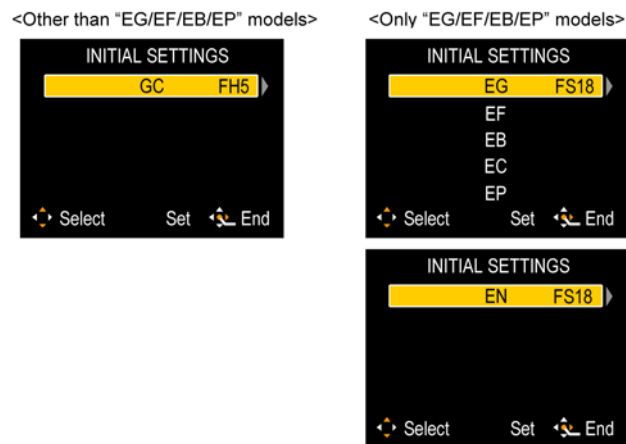

• **Step 5. Choose the model suffix in "INITIAL SETTINGS": (Refer to "CAUTION 1")**

[Caution: After replacing MAIN P.C.B.]

The model suffix can be chosen, **JUST ONE TIME**.

Once one of the model suffix have been chosen, the model suffix lists will not be displayed, thus, it can not be changed.

Therefore, select the area carefully.

Select the area with pressing "[UP] / [DOWN] of Cursor buttons".

• **Step 6. Set the model suffix in “INITIAL SETTINGS”:**

Press the “[RIGHT] of Cursor buttons”.

The only set area is displayed, and then press the “[RIGHT] of Cursor buttons” after confirmation.

(The unit is powered off automatically.)

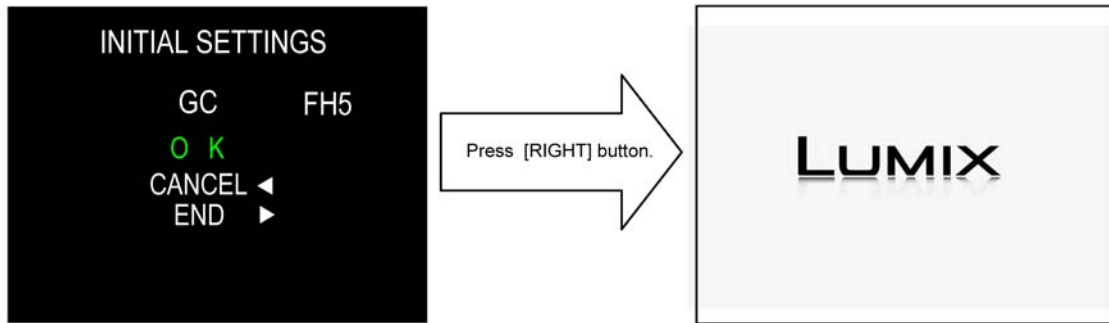

• **Step 7. CONFIRMATION:**

Confirm the display of “PLEASE SET THE CLOCK” in concerned language when the unit is turned on again.

When the unit is connected to PC with USB cable, it is detected as removable media.

(When the “GT” or “GK” model suffix is selected, the display shows “PLEASE SET THE CLOCK” in Chinese.)

1) As for your reference, major default setting condition is as shown in the following table.

• **Default setting (After “INITIAL SETTINGS”)**

	MODEL	VIDEO OUTPUT	LANGUAGE	DATE	REMARKS
a)	DMC-FH5(Japan domestic model)	NTSC	Japanese	Year/Month/Date	
b)	DMC-FH5P	NTSC	English	Month/Date/Year	
c)	DMC-FS18EG	PAL	English	Date/Month/Year	
d)	DMC-FH5PU	NTSC	Spanish	Month/Date/Year	
e)	DMC-FH5GD	NTSC	Korean	Year/Month/Date	
f)	DMC-FH5GC	PAL	English	Date/Month/Year	
g)	DMC-FH5GT	NTSC	Chinese (traditional)	Year/Month/Date	
h)	DMC-FH5GK	PAL	Chinese (simplified)	Year/Month/Date	
i)	DMC-FS18EF	PAL	French	Date/Month/Year	
j)	DMC-FS18EB	PAL	English	Date/Month/Year	
k)	DMC-FS18EE	PAL	Russian	Date/Month/Year	
l)	DMC-FH5GN	PAL	English	Date/Month/Year	
m)	DMC-FH5PC	NTSC	English	Month/Date/Year	
n)	DMC-FH5PR	PAL	Spanish	Date/Month/Year	
o)	DMC-FS18EP	PAL	English	Date/Month/Year	
p)	DMC-FH5GF	PAL	English	Date/Month/Year	
q)	DMC-FH5GM	PAL	English	Date/Month/Year	
r)	DMC-FH5GA	PAL	English	Date/Month/Year	

4 Specifications

Digital Camera:

Information for your safety

Power Source:	DC 5.1 V	
Power Consumption:	1.1 W (When recording) 0.7 W (When playing back)	
Camera effective pixels	16,100,000 pixels	
Image sensor	1/2.33" CCD, total pixel number 16,600,000 pixels, Primary color filter	
Lens	Optical 4×zoom, f=5 mm to 20 mm (35 mm film camera equivalent: 28 mm to 112 mm)/F3.1 (Wide) to F6.5 (Tele)	
Digital zoom	Max. 4×	
Extended optical zoom	Max. 9× (When set to 3,000,000 pixels [3M] or less)	
Focus range	Normal	50 cm (1.64 feet) (Wide)/1 m (3.28 feet) (Tele) to ∞
	Macro/ Intelligent auto/ Motion picture	5 cm (0.17 feet) (Wide)/1 m (3.28 feet) (Tele) to ∞
	Scene Mode	There may be differences in the above settings.
Shutter system	Electronic shutter+Mechanical shutter	
Burst recording		
Burst speed	Approx. 2.0 pictures/second	
Number of recordable pictures	Depends on the remaining capacity of the built-in memory/card.	
Hi-speed burst		
Burst speed	Approx. 6 pictures/second [3M (4:3), 2.5M (3:2) or 2M (16:9) is selected as the picture size.]	
Number of recordable pictures	When using the built-in memory: Approx. 15 pictures (immediately after formatting) When using a Card: Max. 100 pictures (differs depending on the type of Card and the recording conditions)	
Shutter speed	8 seconds to 1/1600th of a second [Starry Sky] Mode: 15 seconds, 30 seconds, 60 seconds	
Exposure (AE)	Program AE Exposure compensation (1/3 EV Step, -2 EV to +2 EV)	
Metering mode	Multiple	

LCD monitor	2.7" TFT LCD (4:3) (Approx. 230,000 dots) (field of view ratio about 100%)
Flash range	Approx. 40 cm (1.32 feet) to 3.3 m (10.8 feet) (Wide, [ISO] is set)
Microphone	Monaural
Speaker	Monaural
Recording media	Built-in Memory (Approx. 70 MB)/SD Memory Card/ SDHC Memory Card/SDXC Memory Card
Recording file format	
Still Picture	JPEG (based on "Design rule for Camera File system", based on "Exif 2.3" standard)/DPOF corresponding
Motion pictures	"QuickTime Motion JPEG" (motion pictures with audio)
Interface	
Digital	"USB 2.0" (High Speed)
Analog video/audio	[for NTSC areas] NTSC [for PAL areas] NTSC/PAL Composite (Switched by menu) Audio line output (monaural)
Terminal	
[AV OUT/ DIGITAL]	Dedicated jack (8 pin)
Dimensions (excluding the projecting parts)	Approx. 94.3 mm (W)×53.5 mm (H)×18.8 mm (D) [3.7"(W)×2.1"(H)×0.7"(D)]
Mass (weight)	Approx. 121 g/0.27 lb (with card and battery) Approx. 104 g/0.23 lb (excluding card and battery)
Operating temperature	0 °C to 40 °C (32 °F to 104 °F)
Operating humidity	10%RH to 80%RH

Battery Charger:

Information for your safety

Input:	AC ~110 V to 240 V, 50/60 Hz, 0.2 A
Output:	DC ---4.2 V, 0.43 A

Equipment mobility: Movable

Battery Pack (lithium-ion):

Information for your safety

Voltage/capacity:	3.6 V/660 mAh
--------------------------	---------------

NOTE:(Only for "EB/EF/EG/EP" models)

- Data from the PC can not be written to the camera using the USB connection cable.
- Motion pictures can be recorded continuously for up to 15 minutes.

5 Location of Controls and Components

- 1 Flash
- 2 Lens
- 3 Self-timer indicator
AF Assist Lamp

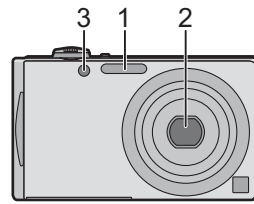

- 4 LCD monitor
- 5 [MENU/SET] button
- 6 [DISP.] button
- 7 [Q.MENU] /Delete /Cancel button
- 8 [MODE] button
- 9 [Rec]/[Playback] selector switch

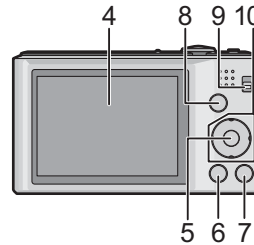

- 10 Cursor buttons
 - (A): ▲/Exposure compensation
 - (B): ▼/Macro Mode
AF Tracking
 - (C): ◀/Self-timer
 - (D): ▶/Flash setting

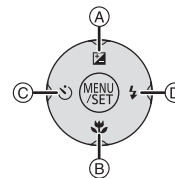

- 11 Strap eyelet
 - Be sure to attach the strap when using the camera to ensure that you will not drop it.
- 12 Lens barrel
- 13 [AV OUT/DIGITAL] socket

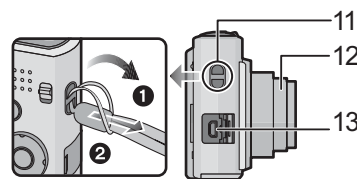

- 14 Camera ON/OFF switch
- 15 Zoom lever
- 16 Speaker
 - Do not cover the speaker with your fingers.
- 17 Microphone
- 18 Shutter button
- 20 Tripod receptacle
- 21 Card/Battery door
- 22 DC coupler cover
 - When using an AC adaptor, ensure that the Panasonic DC coupler (optional) and AC adaptor (optional) are used.
- 23 Release lever

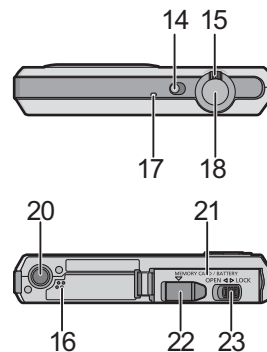

Selecting the [Rec] Mode

1 Slide the [Rec]/[Playback] selector switch to [📷].

2 Press [MODE].

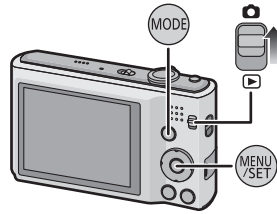

3 Press ▲/▼/◀/▶ to select the mode.



4 Press [MENU/SET].

■ List of [Rec] Modes

iA	Intelligent Auto Mode
The subjects are recorded using settings automatically selected by the camera.	
📷	Normal Picture Mode
The subjects are recorded using your own settings.	
MS	My Scene Mode
Pictures are taken using previously registered recording scenes.	
SCN	Scene Mode
This allows you to take pictures that match the scene being recorded.	
📹	Motion Picture Mode
This mode allows you to record motion pictures with audio.	

6 Service Mode

6.1. Error Code Memory Function

1. General description

This unit is equipped with history of error code memory function, and can be memorized 16 error codes in sequence from the latest. When the error is occurred more than 16, the oldest error is overwritten in sequence.

The error code is not memorized when the power supply is shut down forcibly (i.e., when the unit is powered on by the battery, the battery is pulled out) The error code is memorized to FLASH-ROM when the unit has just before powered off.

2. How to display

The error code can be displayed by ordering the following procedure:

• Preparation:

1. Attach the Battery or AC Adaptor with a DC coupler to the unit.

NOTE:

*Since this unit has built-in memory, it can be performed without inserting SD memory card.

2. Turn the Power on.

3. Press the [MODE] button, and select the [NORMAL PICTURE] mode by Cursor buttons, then press the [MENU/SET] button.

• Step 1. The temporary cancellation of "INITIAL SETTINGS":

Set the [REC]/[PLAYBACK] selector switch to "[REC] (Camera mark)".

While pressing "[UP] of Cursor button" and [W] of Zoom lever simultaneously, turn the Power on.

• Step 2. Execute the error code display mode:

Press the "[LEFT] of Cursor button", "[MENU/SET]" button and "[DISP.]" button are pressed simultaneously.

Every time when performing above operation, the display is changed as shown below.

Normal display → Error code display → Operation history display → Normal display →.....

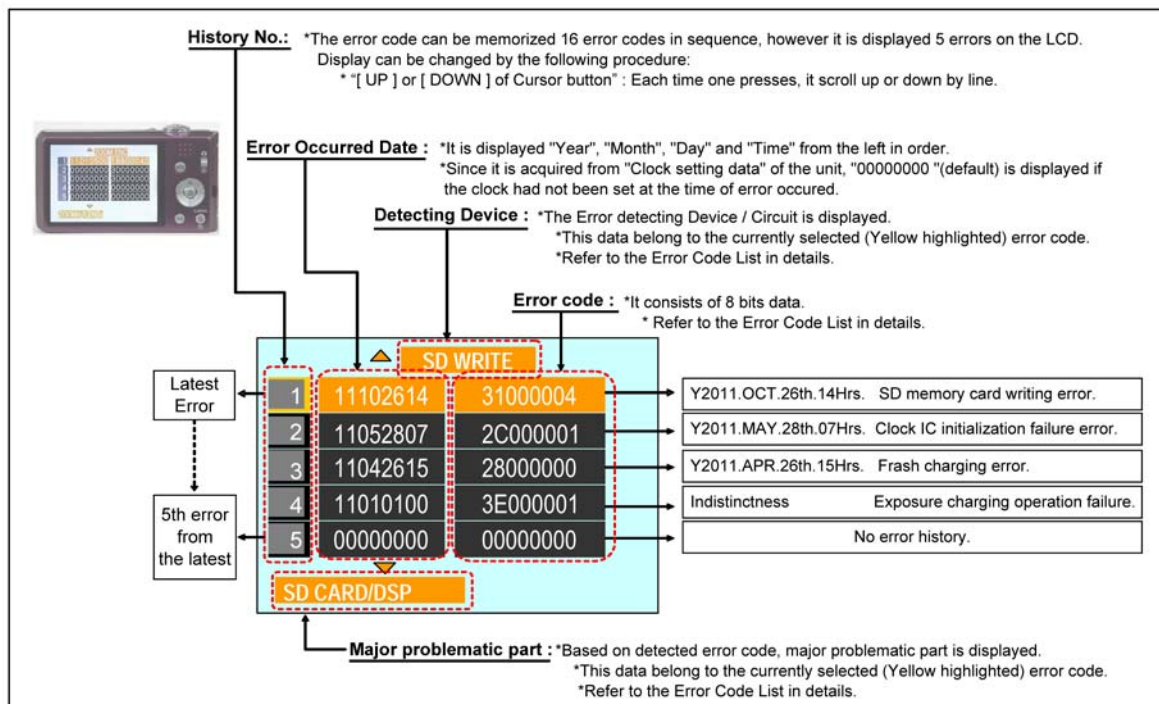

Example of Error Code Display

• 3. Error Code List

The error code consists of 8 bits data and it shows the following information.

Attribute	Main item	Sub item	Error code		Contents (Upper line)		Error Indication	
			High 4 bits	Low 4 bits	Problematic Part & Check point (Lower line)		Detecting device	Problematic Part/Circuit
LENS	Lens drive	OIS	18*0	1000	PSD (X) error. Hall element (X axis) position detect error in OIS unit. Lens Unit.	OIS X	LENSu NG	
				2000	PSD (Y) error. Hall element (Y axis) position detect error in OIS unit. Lens Unit.	OIS Y		
			3000	GYRO (X) error. Main P.C.B..	GYRO X	GYRO NG		
				4000	GYRO (Y) error. Main P.C.B..		GYRO Y	
			5000	MREF error (Reference voltage error). Main P.C.B..	OIS REF	LENSSd/DSP NG		
				6000	Drive voltage (X) error. LENS Unit, LENS flex breaks, etc.	OISX REF	LENSu/LENS FPC	
			7000		Drive voltage (Y) error. LENS Unit, LENS flex breaks, etc.	OISY REF		
		Zoom	0710	Collapsible barrel Low detect error (Collapsible barrel encoder always detects Low.) Lens Unit, Main P.C.B..	ZOOM L	ZOOMm/LENSu		
				0720	Collapsible barrel High detect error (Collapsible barrel encoder always detects High.) Lens Unit, Main P.C.B..		ZOOM H	
		Focus	0701	HP High detect error (Focus encoder always detects High, and not becomes Low) Lens Unit, Main P.C.B..	FOCUS L	LENS FPC/DSP		
				0702	HP Low detect error (Focus encoder always detects Low, and not becomes High) Lens Unit, Main P.C.B..		FOCUS H	
		Lens	18*1	0000	Power ON time out error. Lens Unit, Main P.C.B..	LENS DRV	LENSu	
					18*2			Power OFF time out error. Lens Unit, Main P.C.B..
		Adj. History	OIS	19*0	2000	OIS adj. Yaw direction amplitude error (small)	OIS ADJ	OIS ADJ
	3000				OIS adj. Pitch direction amplitude error (small)			
	4000				OIS adj. Yaw direction amplitude error (large)			
	5000				OIS adj. Pitch direction amplitude error (large)			
	6000				OIS adj. MREF error			
	7000				OIS adj. time out error			
	8000				OIS adj. Yaw direction off set error			
9000	OIS adj. Pitch direction off set error							
A000	OIS adj. Yaw direction gain error							
B000	OIS adj. Pitch direction gain error							
C000	OIS adj. Yaw direction position sensor error							
D000	OIS adj. Pitch direction position sensor error							
E000	OIS adj. other error							
HARD	VENUS A/D				Flash	28*0		
	FLASH ROM (EEPROM Area)	FLASH ROM (EEPROM Area)	2B*0	0001	EEPROM read error Main P.C.B..	FROM RE	FROM	
				0002	EEPROM write error Main P.C.B..	FROM WR	FROM	
			0005	Firmware version up error Replace the firmware file in the SD memory card.	(No indication)	(No indication)		
				0008	SDRAM error			
	SYSTEM	RTC	2C*0	0001	SYSTEM IC initialize failure error Main P.C.B..	SYS INIT	MAIN PCB	
					SOFT	CPU	Reset	30*0
Card	Card	31*0	0001	Card logic error SD Memory card, Main P.C.B..				
			0002	Card physical error SD Memory card, Main P.C.B..				
			0004	Write error SD Memory card, Main P.C.B..	SD WRITE			
CPU, ASIC hard	Stop	38*0	0001	Camera task finish process time out. Lens Unit, Main P.C.B..	LENS COM	LENSu/DSP		
				0002	Camera task invalid code error. Main P.C.B..	DSP	DSP	
				0100	File time out error in recording motion image Main P.C.B..			
				0200	File data cue send error in recording motion image Main P.C.B..			
				0300	Single or burst recording brake time out.			
Memory area	3A*0	0008	USB work area partitioning failure USB cable, Main P.C.B..	(No indication)	(No indication)			
			Operation	Power on	3B*0	0000	FLASHROM processing early period of camera during movement.	INIT
Zoom	Zoom	3C*0					0000	Inperfect zoom lens processing Lens Unit.
			35*0	0000	Software error (0-7bit : command, 8-15bit : status) FFFF	DSP		DSP
		35*1			0000	Though record preprocessing is necessary, it is not called.	(No indication)	(No indication)
			35*2	0000		Though record preprocessing is necessary, it is not completed.		

Important notice about "Error Code List"

1) About "*" indication:

The third digit from the left is different as follows.

- In case of 0 (example: 18001000)

When the third digit from the left shows "0", this error occurred under the condition of INITIAL SETTINGS has been completed.

It means that this error is occurred basically at user side.

- In case of 8 (example: 18801000)

When the third digit from the left shows "8", this error occurred under the condition of INITIAL SETTINGS has been released.

(Example; Factory assembling-line before unit shipment, Service mode etc.)

It means that this error is occurred at service side.

2) About "?" indication: ("18*0 0?01" to "18*0 0?50"):

The third digit from the right shows one of the hexadecimal ("0" to "F") character.

• 4. How to exit from Error Code display mode:

Simply, turn the power off. (Since Error code display mode is executed under the condition of temporary cancellation of "INITIAL SETTINGS", it wake up with normal condition when turn off the power.)

NOTE:

The error code can not be initialized.

6.2. ICS (Indication of additional Camera Settings when picture was taken) function

1. General description

This unit is equipped with ICS (ICS: Indication of additional Camera Settings when picture was taken) function by playing back the concerned picture on the LCD display.

(This function is achieved by utilizing "maker note" data stored in Exif data area of recorded picture file.)

To proceed failure diagnosis, use this ICS function together with "displaying the recorded picture with picture information" function.

NOTE:

- The ICS function operates with a picture which is only taken with the same model. (It may not be displayed when the picture was taken with other model.)
- Since Exif data is not available after the picture is edited by PC, the ICS function may not be activated.

2. How to display

The ICS data is displayed by ordering the following procedure:

• Preparation:

1. Attach the Battery or AC Adaptor with a DC coupler to the unit.

NOTE:

Set the mode dial to "Normal picture mode", to display the ICS data.

• Step 1. The temporary cancellation of "INITIAL SETTINGS":

Set the [REC]/[PLAYBACK] selector switch to "[REC] (Camera mark)".

While pressing "[UP] of Cursor button" and "[W] of zoom lever" simultaneously, turn the Power on.

• Step 2. Execute the ICS display mode:

Set the [REC]/[PLAYBACK] selector switch to [PLAYBACK].

Select the concerned picture by pressing the "[LEFT] and [RIGHT] of Cursor button".

Press the "[LEFT] of Cursor button", [MENU/SET] button and [DISP.] button simultaneously.

Press the [DISP.] button, 3 times.

The display condition is changed as shown below when the [DISP.] button is pressed.

Code display → Code + Picture display (1) → Code + Picture display (2) → ICS display → Code display

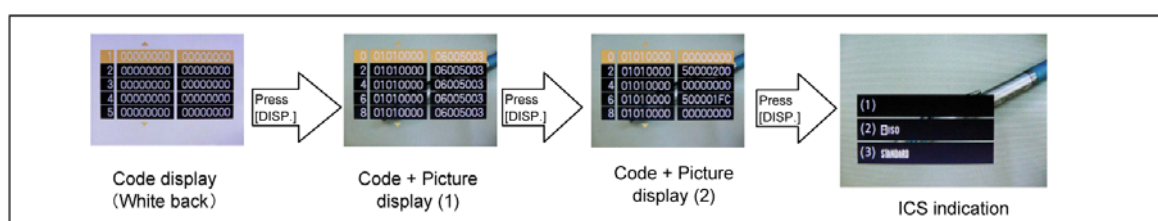

3. How to read

(1). Jitter alert was displayed or not:
 This part shows that the "Jitter alert" mark was displayed or not when the picture has just before been taken.
 + With "Jitter alert" mark : The "Jitter alert" mark was displayed.
 + Without "Jitter alert" mark: The "Jitter alert" mark was not displayed.
 [About "Jitter alert" mark]
 Due to lacking the enough light amount etc, shooting condition prone to make a "hand jitter", the "Jitter alert" mark is displayed.
 [Reference Guide]
 (Applicable settings : Normal picture mode, ISO100, WIDE edge, Flash OFF)
 + The "Jitter alert" mark is displayed when the shutter speed is 1/15th and below.

(2). ISO Sensitivity Setting condition:
 This part shows that the "ISO Sensitivity" setting condition when the picture had been taken.
 (Note: The [i ISO] is displayed when the "Intelligent ISO" was selected.)
 For instance, when the recorded picture information shows [ISO100], it can be confirmed the ISO setting condition : [AUTO], [INTELLIGENT ISO] or [ISO 100](Fixed: set by user).
 [Point for Confirmation]
 *The symptom is "Picture with "hand jitter". Subject is not clearly stopped." in darker scene, does the picture was taken with lower ISO setting mode?
 *The symptom is "Noisy picture. Rough picture image" in brighter scene, does the picture was taken with higher ISO setting mode?

(3). Color mode Setting condition:
 This part shows that the "Color mode" setting condition when the picture had been taken.
 [Point for Confirmation]
 *The symptom is "Color is strange. The picture is bluish (Yellowish) ", does the picture was taken with [SEPIA] / [COOL] / [WARM] settings?
 NOTE: As for the symptom related with the color, confirm the picture information which is displayed in normal playback screen as well.
 (In normal playback screen, the setting condition of "White balance" and "WB Adjustment "can be confirmed.)

[Reference Guide : Settings "When taking picture"]

<ISO SENSITIVITY>
 *This allows the sensitivity to light (ISO sensitivity) to be set. Setting to a higher figure enables pictures to be taken even in dark places without the resulting pictures coming out dark.
 *In this unit, it can be set one of the [AUTO], [100], [200], [400], [800] and [1600] in "Normal shooting" mode.
 *In Intelligent Auto Mode, shutter speed changes depending on the identified scene.

	[100] ←	→ [1600]
Recording location (recommended)	When it is light (outdoors)	When it is dark
Shutter speed	Slow	Fast
Noise	Less	Increased
Jitter of the subject	Increased	Less

<COLOR MODE>
 *Using these modes, the pictures can be made sharper or softer, the colors of the pictures can be turned into sepia colors or other color effects can be achieved.
 *In this unit, it can be set one of the following effects in "Normal shooting" mode.

[STANDARD] : This is the standard setting.	[B/W] : The picture becomes black and white
[Happy]*1 : Image with enhanced brightness and vividness.	[SEPIA] : The picture becomes sepia.
[NATURAL]*2 : The picture becomes softer.	[COOL]*2 : The picture becomes bluish.
[VIVID]*2 : The picture becomes sharper.	[WARM]*2 : The picture becomes reddish.

*When you take pictures in dark places, noise may become visible. To avoid noise, we recommend setting to [NATURAL].

Normal playback screen
(Recorded picture with information)



*In playback mode, the picture information is displayed when pressing the [DISPLAY] button. (It can be confirmed at user as well.)
 *Use this indication together with ICS function

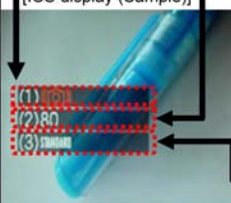

[ICS display (Sample)]

(1). Jitter alert mark : [Indicated]
 (2). ISO sens. setting : ISO100
 (3). Color mode setting: Standard



4. How to exit:

Simply, turn the power off. (Since ICS function is executed under the condition of temporary cancellation of "INITIAL SETTINGS", it wake up with normal condition when turn off the power.)

7 Service Fixture & Tools

7.1. Service Fixture and Tools

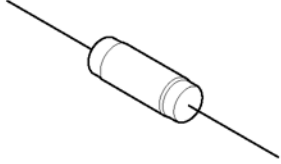
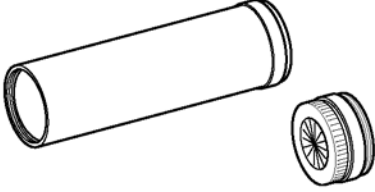
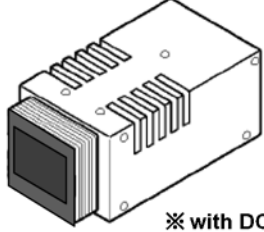
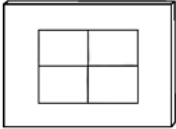
The following Service Fixture and tools are used for checking and servicing this unit.

Resistor for Discharging ERG5SJ102	Infinity Lens (with Focus Chart) VFK1164TCM02	LIGHT BOX RFKZ0523
 An equivalent type of Resistor may be used.	 * VFK1164TCM03 can be used. * RFKZ0422 can be used.	 ※ with DC Cable * VFK1164TDVLB can be used.
TR Chart RFKZ0443	Lens Cleaning Kit (BK) VFK1900BK	ND Filter (ND1.5) VFK1164ND15
	 * Only supplied as 10 set/box.	

7.2. When Replacing the Main P.C.B.

After replacing the MAIN P.C.B., be sure to achieve adjustment.

The service software is available at "TSN Website". To download, click on "Support Information from NWBG/VDBG-AVC".

8 Disassembly and Assembly Instructions

8.1. Disassembly Flow Chart

This is a disassembling chart.

When assembling, perform this chart conversely.

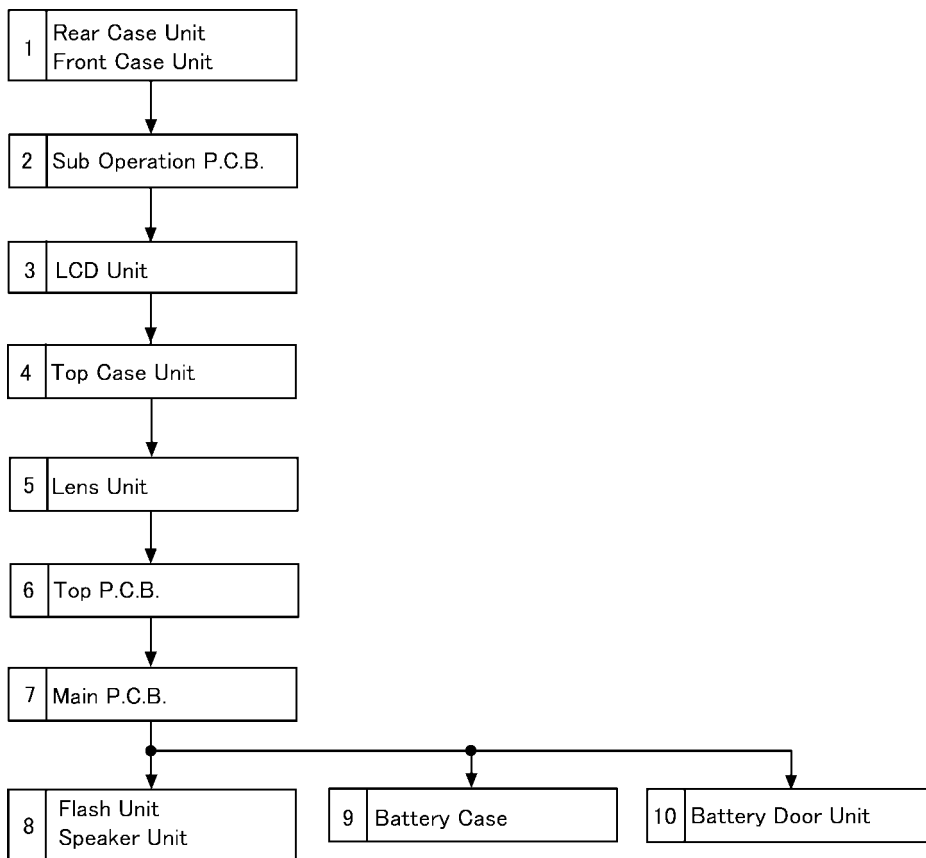

8.2. P.C.B. Location

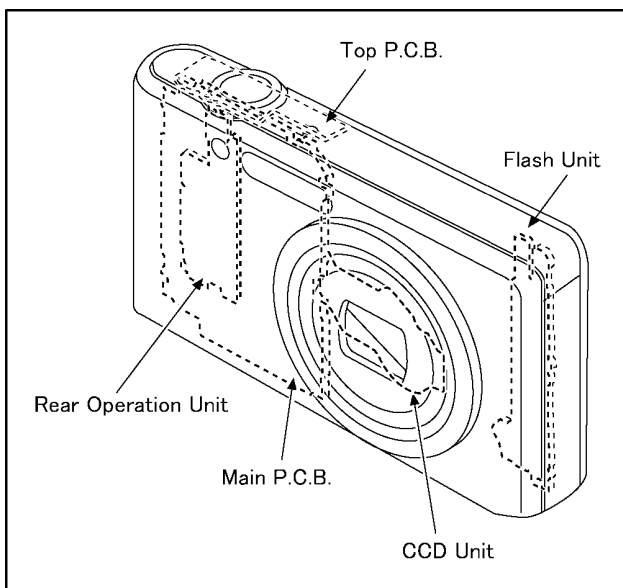

8.3. Disassembly Procedure

8.3.1. Removal of the Rear Case Unit and Front Case Unit

No.	Item	Fig	Removal
1	Rear Case Unit Front Case Unit	(Fig. D1)	Card
			Battery
			1 Screw (A)
			4 Screws (B)
			2 Screws (C)
		(Fig. D2)	Side Ornament R
			1 Screw (D)
			1 Locking tab
			Rear Case Unit
			2 Locking tabs
			Front Case Unit
2	Sub Operation P.C.B.	(Fig. D3)	PP9501(Connector) Sub Operation P.C.B.
3	LCD Unit	(Fig. D4)	2 Locking tabs
			PCB Spacer
			1 Screw (E)
			FP9003(Flex)
			LCD Unit
4	Top Case Unit	(Fig. D5)	2 Screws (F)
			Frame Plate A
			2 Locking tabs
			Power Knob
			Top Case Unit
5	Lens Unit	(Fig. D6)	1 Screw (G)
			Front Ornament
			FP9001(Flex)
			FP9004(Flex)
			FP9002(Flex)
			Lens Unit
6	Top P.C.B.	(Fig. D7)	Solder (14 points)
			1 Screw (H)
			AF Panel Light
			Top P.C.B.
7	Main P.C.B.	(Fig. D8)	1 Screw (I)
			1 Screw (J)
			Main P.C.B.
8	Flash Unit Speaker	(Fig. D9)	1 Screw (K)
		(Fig. D10)	Solder (5 points)
			2 Locking tabs
			SP sheet
			Flash Unit Speaker
9	Battery Case	(Fig. D11)	1 Locking tab
			Battery Out Spring
			Battery Case
10	Battery Door Unit	(Fig. D12)	Battery Door Shaft
			Battery Door Spring
			Jack Door
			Battery Lock Knob
			Battery Lock Spring
			Battery Door Unit

NOTE:

When servicing and reassembling, remove the card and battery from the unit.

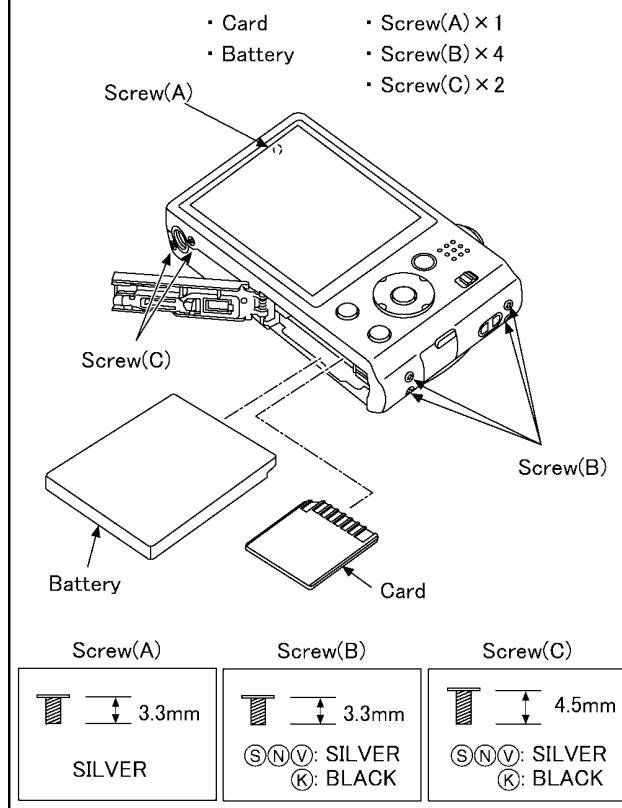

(Fig. D1)

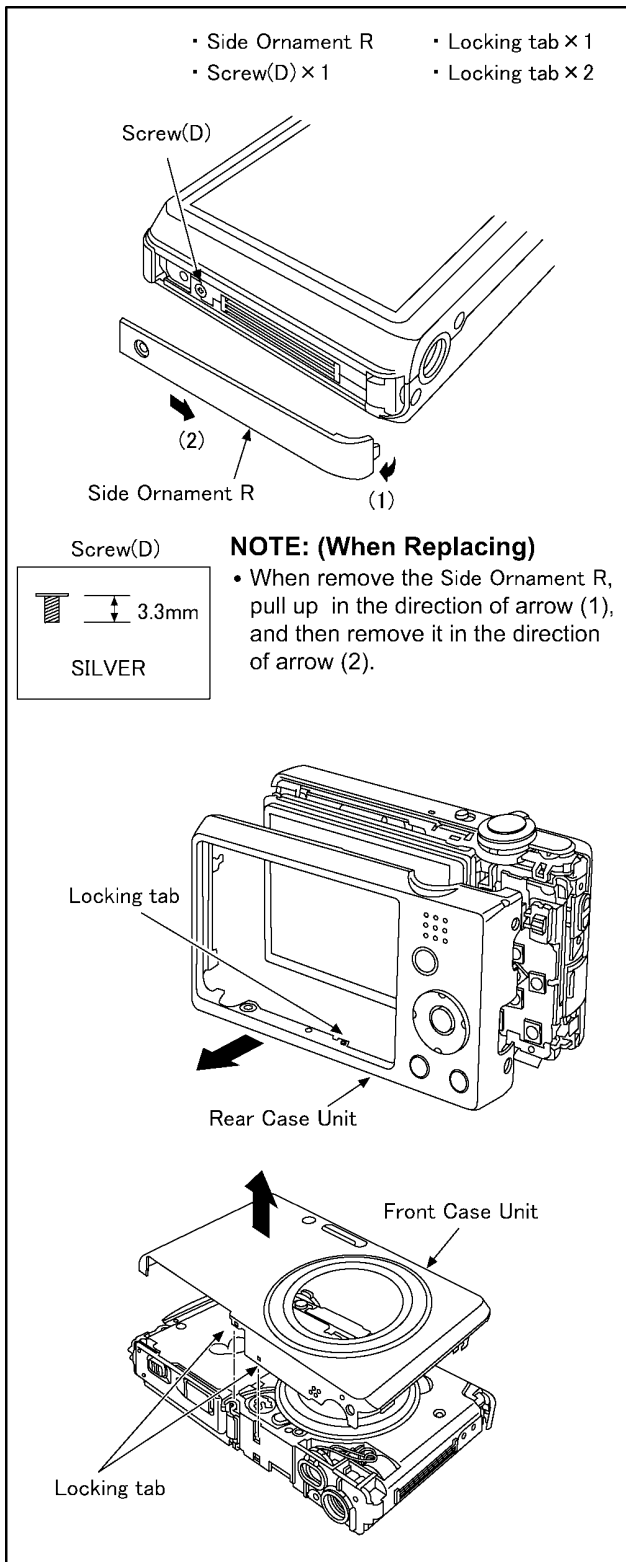

(Fig. D2)

8.3.2. Removal of the Sub Operation P.C.B.

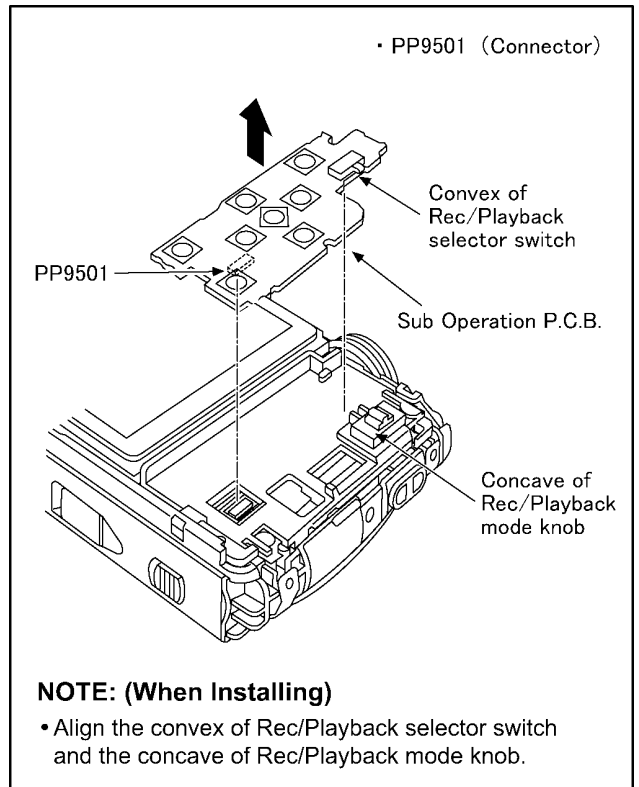

(Fig. D3)

8.3.3. Removal of the LCD Unit

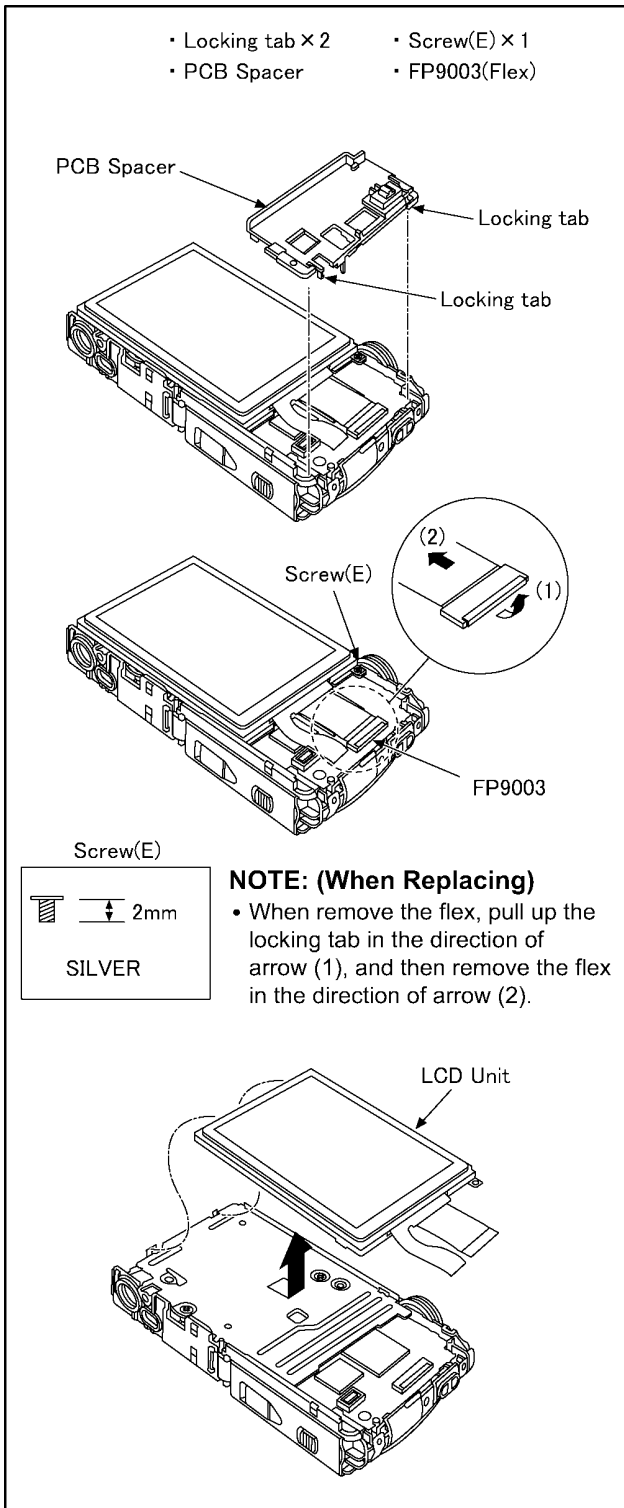

(Fig. D4)

8.3.4. Removal of the Top Case Unit

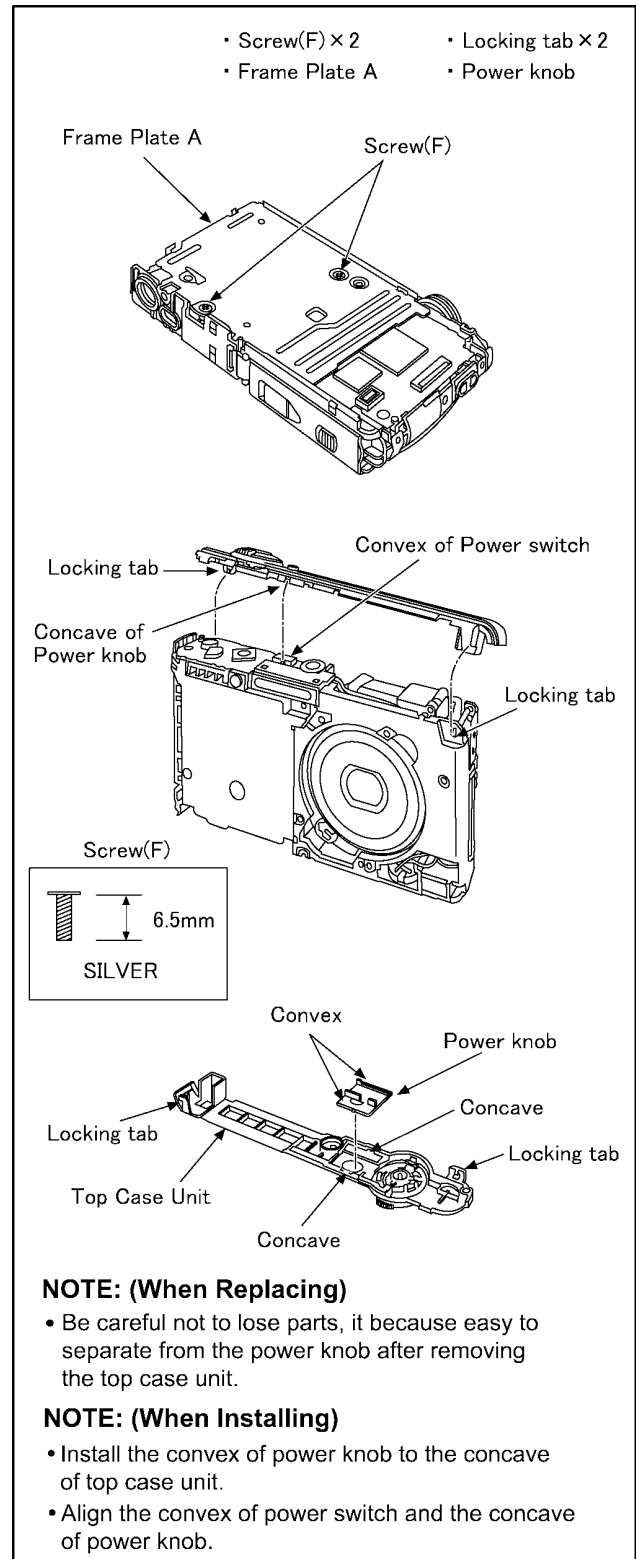

(Fig. D5)

8.3.5. Removal of the Lens Unit

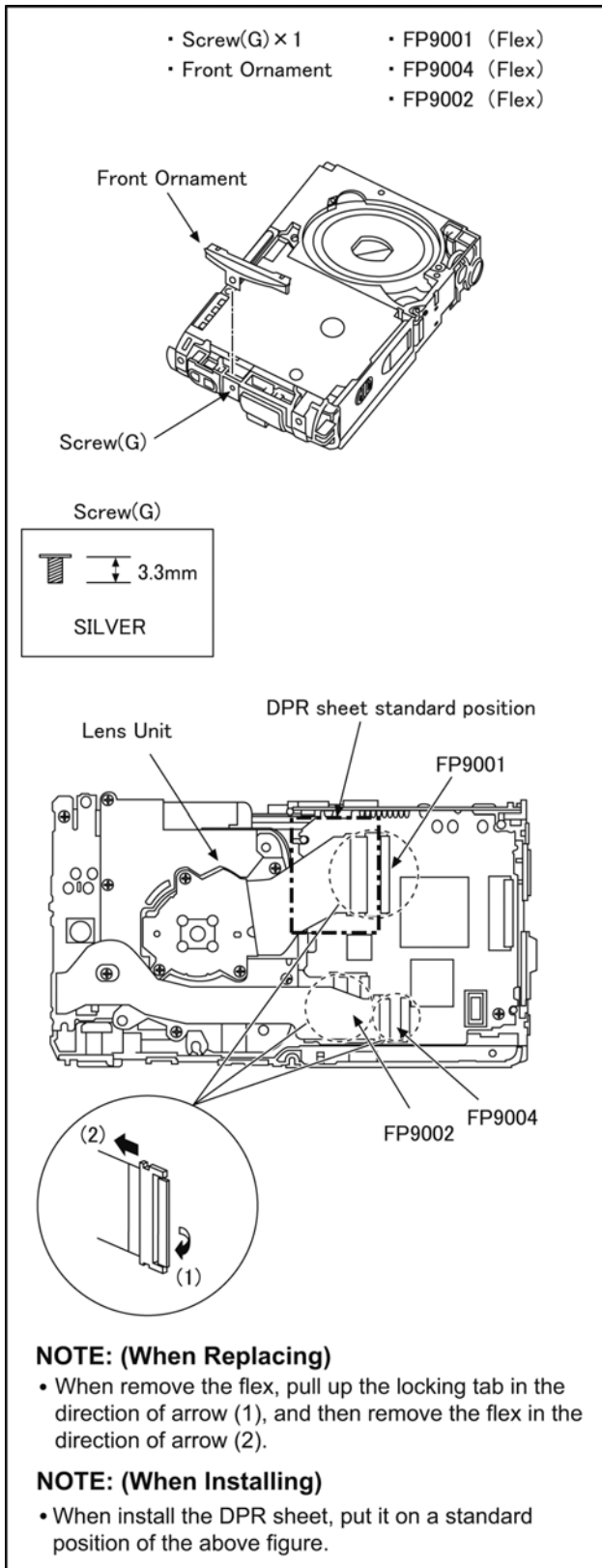

(Fig. D6)

8.3.6. Removal of the Top P.C.B.

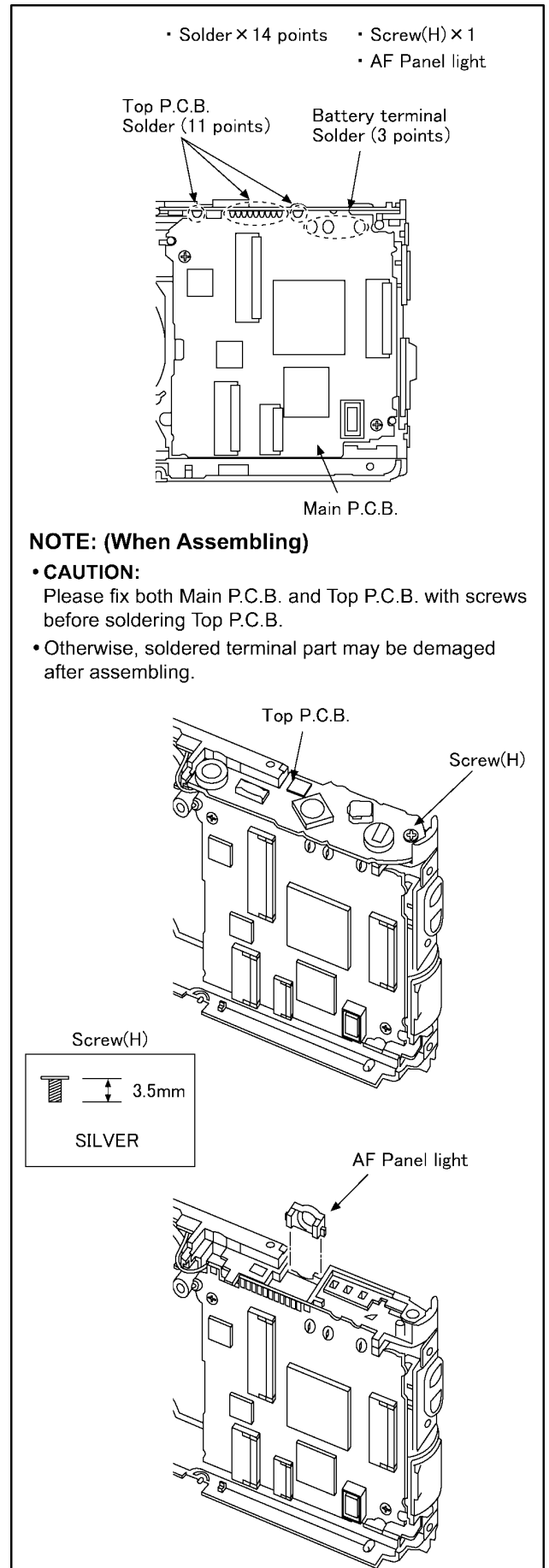

(Fig. D7)

8.3.7. Removal of the Main P.C.B.

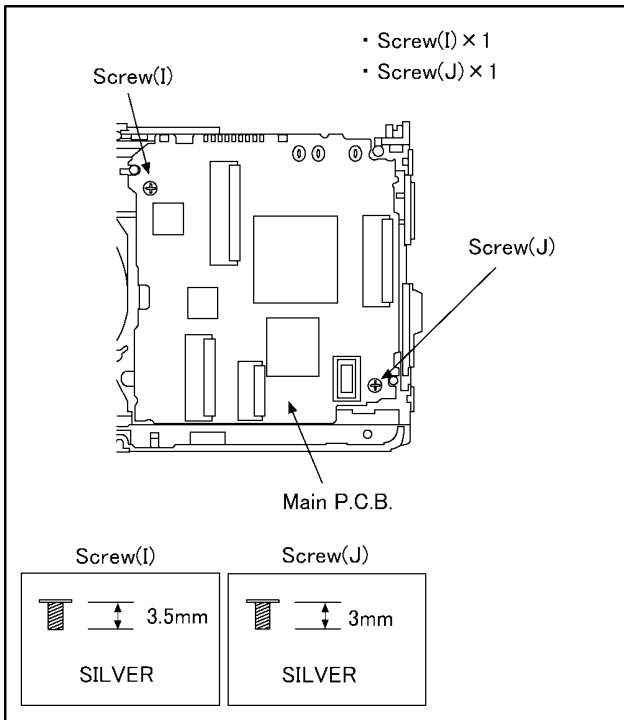

(Fig. D8)

8.3.8. Removal of the Flash Unit and Speaker

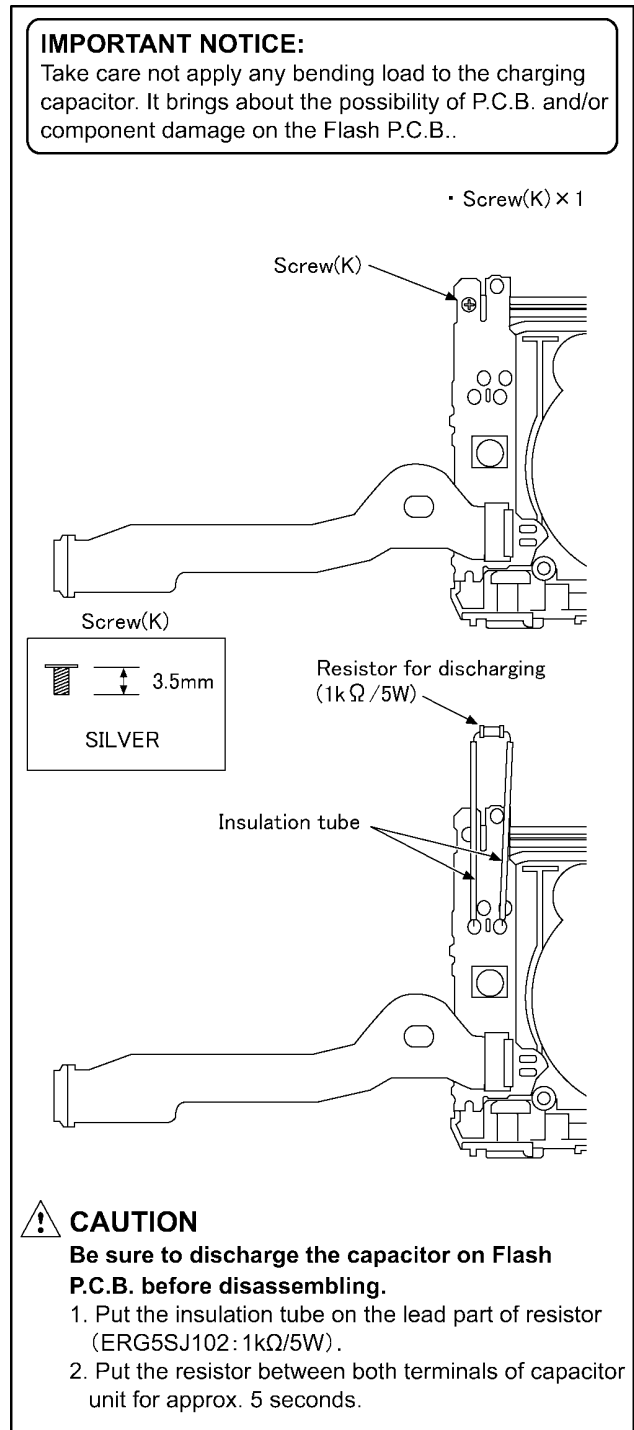

(Fig. D9)

IMPORTANT NOTICE:

Take care not apply any bending load to the charging capacitor. It brings about the possibility of P.C.B. and/or component damage on the Flash P.C.B..

- Solder × 5 points
- SP sheet
- Locking tab × 2

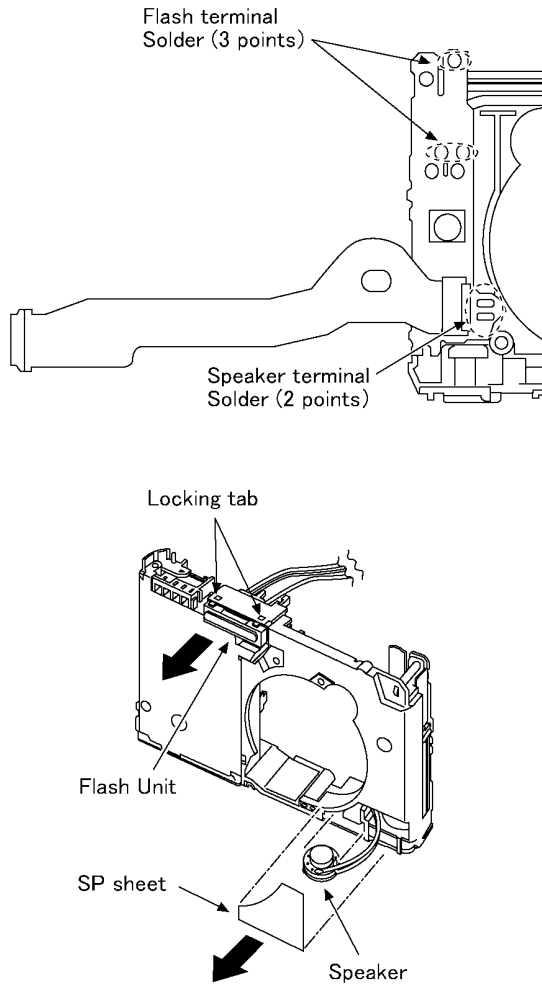

(Fig. D10)

8.3.9. Removal of the Battery Case

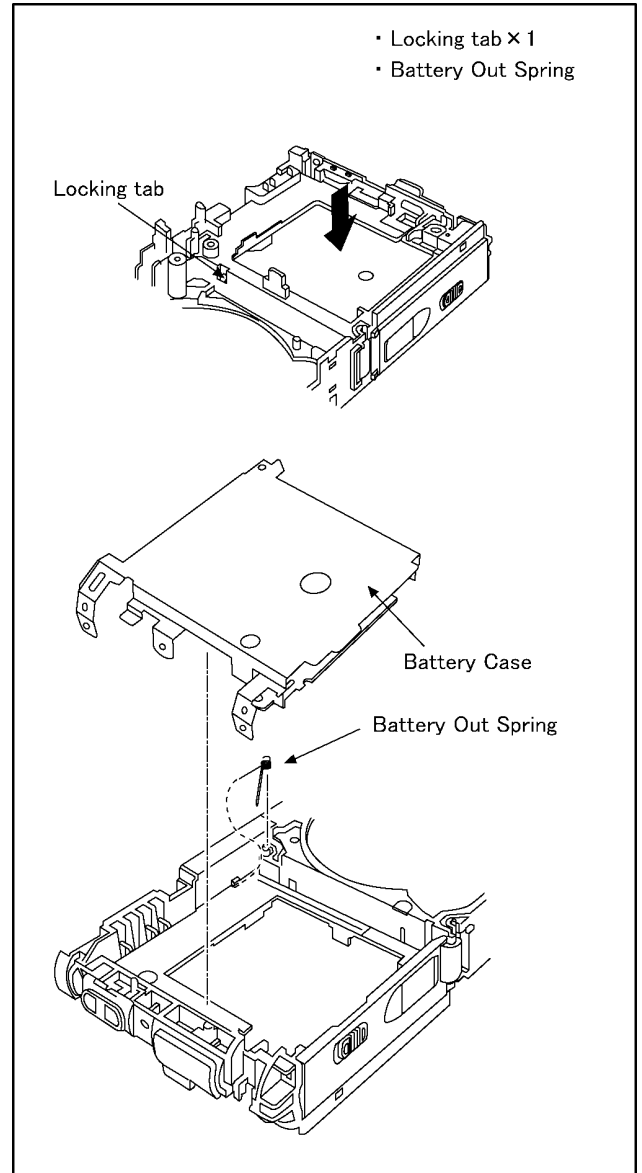

(Fig. D11)

8.3.10. Removal of the Battery Door Unit

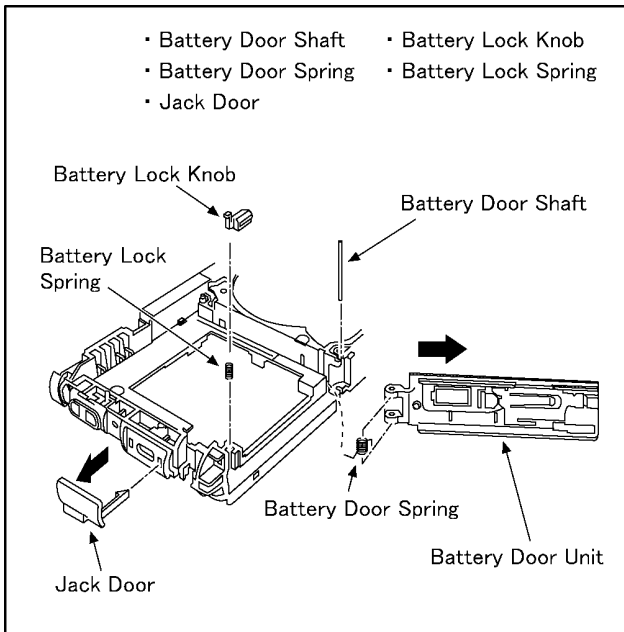

(Fig. D12)

NOTE: (When Installing)

Make sure to confirm the following points when installing:

- The Screw is tightened enough.
- Installing conditions are fine. (No distortion, no abnormal-space.)
- No dust and/or dirt on Lens surfaces.
- LCD image is fine. (No dust and dirt on it, and no gradient images.)

8.4. Removal of the CCD Unit

To prevent the CCD unit from catching the dust and dirt, do not remove the CCD unit except for replacing.

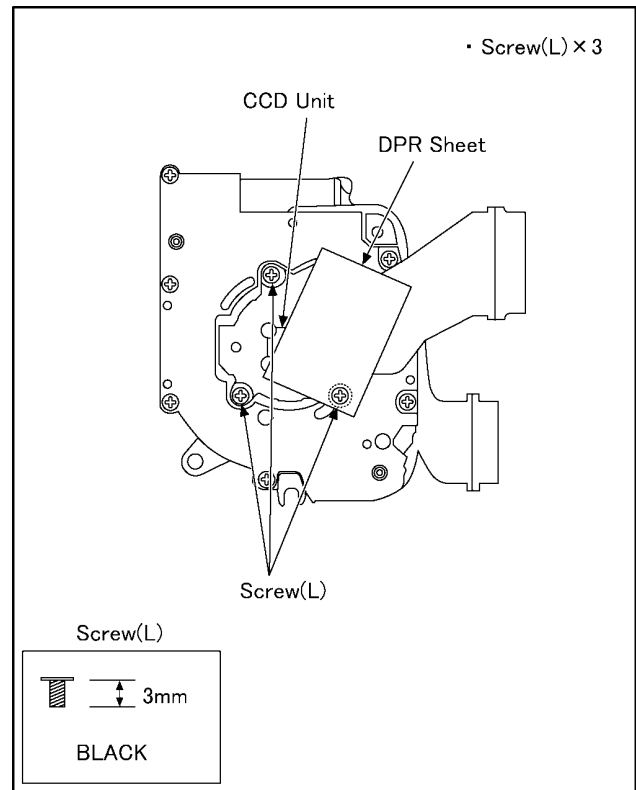

(Fig. D13)

9 Measurements and Adjustments

9.1. Introduction

When servicing this unit, make sure to perform the adjustments necessary based on the part(s) replaced. Before disassembling the unit, it is recommended to back up the camera data stored in flash-rom as a data file.

IMPORTANT NOTICE (After replacing the MAIN P.C.B.)

After replacing the MAIN P.C.B., it is necessary to use the "DIAS" software to allow the release of adjustment flag(s). The Adjustment software "DIAS" is available at "TSN Website". To download, click on "Support Information from NWBG/VDBG-AVC".

*DIAS (DSC Integrated Assist Software)

9.2. Before Disassembling the unit

9.2.1. Initial Setting Release

The cameras specification are initially set in accordance with model suffix (such as EB, EG, GK, GC, and so on.). Unless the initial setting is not released, an automatic alignment software in the camera is not able to be executed when the alignment is carried out.

Note:

The initial setting should be again done after completing the alignment. Otherwise, the camera may not work properly. Therefore as a warning, the camera display a warning symbol "!" on the LCD monitor every time the camera is turned off. Refer to the procedure described in "3.5.2 INITIAL SETTINGS" for details.

[How to Release the camera initial setting]

Preparation:

- Attach the Battery or AC Adaptor with a DC coupler to the unit.
(Since this unit has built-in memory, it can be performed without inserting SD memory card.)
1. Turn the Power on.
 2. Press the [MODE] button, and select the [NORMAL PICTURE] mode by Cursor buttons, then press the [MENU/SET] button.
 3. Turn the Power off.
(If the unit is other than [NORMAL PICTURE] mode, it does not display the initial settings menu.)

Step 1. Temporary cancellation of "INITIAL SETTINGS":

Set the [REC]/[PLAYBACK] selector switch to "[REC] (Camera mark)". While pressing "[UP] of Cursor button" and [W] of Zoom lever simultaneously, turn the Power on.

Step 2. Cancellation of "INITIAL SETTINGS":

Set the [REC]/[PLAYBACK] selector switch to "[PLAYBACK]". Press "[UP] of Cursor button" and [DISP.] button simultaneously, then turn the Power off.

The LCD displays the "!" mark before the unit powers down.



9.2.2. Flash-Rom Data Backup

When trouble occurs, it is recommended to backup the Flash-rom data before disassembling the unit.

There are two kinds of Flash-rom data backup methods:

[ROM_BACKUP (Method of Non-PC backup)]

1. Insert the SD-card into the camera.
2. Set the camera to "Temporary cancellation of the initial settings".
3. Select the "SETUP" menu.

From the "SETUP" menu, select "ROM BACKUP".

NOTE:

This item is not listed on the customer's "SETUP" menu.

4. When this "ROM_BACKUP" item is selected, the following submenus are displayed.

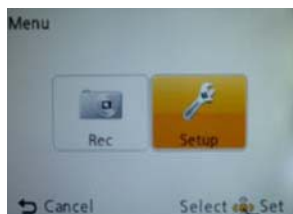

Fig.2-1

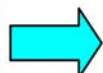

Fig.2-2

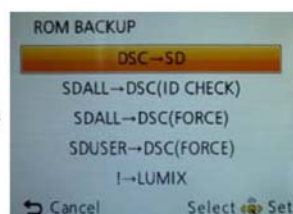
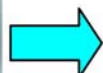

Fig.2-3

Item	Function	Details
DSC → SD	Save all the DSC's Flash-rom data to SD-CARD	*DSC's Flash-rom data is saved to the SD-CARD as a data file by the same format as the TATSUJIN software for the previous models. (DATA BACKUP) -File location: ROOT DIRECTORY in SD-CARD. -File Name: 1) User Setup Information data: <Model Number>U.txt [Example: DMC-FX66 : "FX66U.txt"] 2) Optical Adjustment data: <Model Number>F.txt [Example: DMC-FX66 : "FX66F.txt"] *If the concerned file already exists, "OVERWRITE?" message is displayed.
SDALL→ DSC (ID CHECK)	Write the all data to DSC's Flash-rom from SD-CARD	*The backup data being stored in the SD card is transferred to DSC unit. *ID CHECK: When the model ID is different, data is not transferred.
SDALL→ DSC (FORCE)	Write the all data to DSC's Flash-rom from SD-CARD	*FORCE: Even if the model ID is different, data is transferred. ※If the main PCB is replaced, select "SDALL → DSC (FORCE)".
SDUSER→DSC (FORCE)	Only "User setup information" is written from the saved file in the SD-CARD to DSC's Flash-rom.	*Only the user's "setup" setting condition is transferred to DSC unit. *FORCE: Even if the model ID is different, the data is transferred.
!→LUMIX	Shipping set without initializing "User setup information"	*Initial setting is executed without initializing the user's set up setting condition. ※ The initial setting must be perform while the Self-timer LED is blinking, ※ The picture data stored in the built-in memory of the DSC is not erased, with this operation.

[DSC Integrated Assist Software (Method of Using PC)]

Same as TATSUJIN software for previous models.

9.2.3. Light Box

If using VFK1164TDVLB Light Box, remove the lens connection ring by loosening three hexagonal screws.

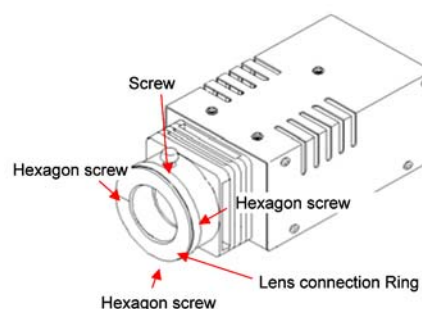

9.3. Details of Electrical Adjustment

9.3.1. How to execute the Electrical Adjustment

It is not necessary to connect the camera to a PC to perform adjustments.

“Flag reset operation” and “Initial setting operation” are required when carrying out the alignment, follow the procedure below.

9.3.1.1. Startup Electrical Adjustment mode

1. Release the initial settings.
2. Insert a recordable SD card.
(Without a SD card, the automatic adjustment can not executed.)
3. Procedure to set the camera into adjustment mode:
 - a. Turn the Power on.
 - b. Press the [MODE] button, and select the [NORMAL PICTURE] mode by Cursor buttons, then press the [MENU/SET] button.
 - c. Turn the Power off.
 - d. Turn the Power on pressing “[W] side of Zoom button” and [MENU/SET] button simultaneously.
LCD monitor displays “SERVICE MODE”.(Refer to Fig. 3-1)

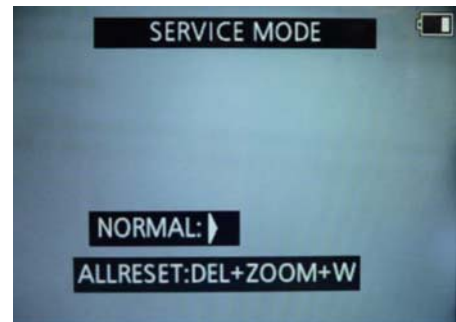

Fig.3-1

9.3.1.2. Status Adjustment Flag Setting

Reset (Not yet adjusted) the status flag condition.

1. After pressing the “DISP”, the LCD monitor displays the Flag status screen (Refer to Fig.3-2)
2. Select item by pressing the Cursor buttons. (Gray cursor is moved accordingly.)
3. Press the [Delete/Return] button.

NOTE:

The selected item's flag has been changed from “F (green)” to “0 (yellow)”.

*Flag conditions:

F (green)

means that the alignment has been completed and the status flag condition is set. In this case, the flag condition should be reset, if you try to carry out the automatic alignment.

0 (yellow)

means that the alignment has been not “completed” and the status flag condition is “reset”. In this case, automatic alignment is available.

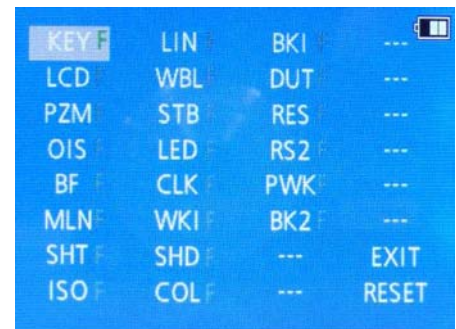

Fig.3-2

- In case of setting the status flag into set condition again without completion of the alignment, the status flag should be SET by using PC, or UNDO by using ROM BACKUP function.

9.3.1.3. Execute Adjustment (In case of “OIS Adjustment”)

1. Perform step “9.3.1.1.” to “9.3.1.2.”, to reset the OIS flag status “F” (Set) to “0” (Reset)
2. Press “DISP” after Flag reset.
OIS Adjustment screen is displayed on the LCD panel.
(Refer to Fig.3-3)
3. Press the [Shutter] button. The adjustment will start automatically.



Fig.3-3

4. When the adjustment is completed successfully, adjustment report menu appears with Green OK on the LCD monitor. (Refer to Fig.3-4)



Fig.3-4

9.3.1.4. Attention point during Adjustment

1. Step “9.3.1.3.” procedure shows OIS adjustment as an example. To perform the adjustment, refer to the “9.3.2. Adjustment Specifications” table which shows key point for each adjustment.
2. Do not move the light box, the camera or the chart while adjusting. If one of these is moved accidentally, start the adjustment again.
3. Do not press any buttons/keys until the default menu (Fig.3-5) is displayed on the LCD monitor. Otherwise, adjustment data may not be stored properly.
4. If the adjustment is interrupted accidentally, the alignment data may not be properly saved in the Flash-rom.

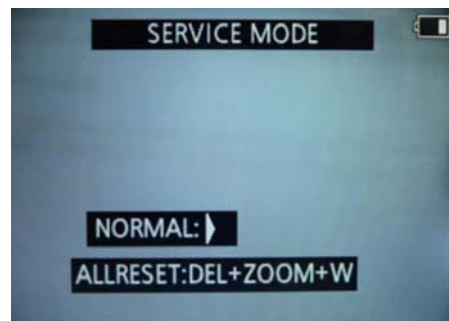

Fig.3-5

9.3.1.5. Finalizing the Adjustment

1. Several adjustment flags can be reset (“F” into “0”) at the same time. In this case, when the adjustment has been completed, the screen will change showing the adjustment for the next item until all reset items are completed.
Also, when the shutter button is pressed, the screen jump to the next adjustment item.
2. To cancel the adjustment mode while in the process of performing the adjustment, follow this procedures.
(1) Press “[RIGHT] of cursor button”.

NOTE:

- If adjustment is cancelled with above procedure, adjustment is not completed. Make sure to adjust it later.
- Adjustment software “DIAS” is able to control the status of the adjustment flags.

9.3.2. Adjustment Specifications

The following matrix table shows the relation between the replaced part and the Necessary Adjustment.

When a part is replaced, make sure to perform the necessary adjustment(s) in the order indicated.

The table below shows all the information necessary to perform each adjustment.

Adjustment order	Adjustment Item	FLAG	Purpose	Replacing Parts			JIG/TOOLS	SET UP	How to Operate
				MAIN P.C.B.	Lens part (Except CCD U)	CCD UNIT			
1	LCD flickering	LCD	Minimize the LCD flickering	○	—	—	NONE	NONE	1)No flickering, just press the shutter Button. 2)There are four LCD mode. (The position of green ●mark is different.) Select LCD modes with less flicking by pressing the left/right cursor buttons. Then press the shutter button.
2	Venus Zoom	PZM	Venus Zoom Inspection	○	—	—	NONE	NONE	1)Press Shutter Button 2)After displaying "PZM", press Shutter Button again. 3)After completed, the "OK" message appears.
3	OIS sensor	OIS	OIS sensor output level adjustment	○	○	—	NONE	NONE	1)Press Shutter Button (Do not apply any shock and vibration for the camera while adjusting) 2)After completed, the "OK" message appears.
4	Backfocus / GYRO	BF	To have the focus tracking curve be appropriate shape and GYRO sensor adjustment	○	○	※1	•COLLIMATOR (VFK1164TCM02 or VFK1164TCM03 or RFKZ0422)	1)Set the camera in front of collimator so that the distance between collimator and camera becomes about 2 cm as shown in Fig.A. 【NOTE】 Please note that "NG" might happen while auto adjusting. - Do not put the black colored stuff at the back side of collimator near hunching chart to get some certain brightness. - Make sure the hunting chart has no dust and dirty condition. - Not connect the USB cable at this stage.	1)Press Shutter Button (Do not apply any shock and vibration for the camera while adjusting) 2)After completed, the "OK" message appears.
5	Monitor Linearity	MLN	Monitor Linearity adjustment	○	○	○	•LIGHT BOX RFKZ0523 (VFK1164TDVLB) •TR CHART (RFKZ0443)	1)Set the camera in front of LIGHTBOX so that the distance between collimator and camera becomes about 3 cm as shown in Fig.B.	1)Press Shutter Button 2)After completed, the "OK" message appears.
6	Shutter	SHT	Shutter speed adjustment	○	○	○		1) Insert the TR chart into the slot of LIGHTBOX. 2) Set the camera in front of LIGHTBOX so that the distance between LIGHTBOX and camera becomes about 13 cm as shown in FigB. 3) Set the camera angle so that the color chart is displayed on the LCD monitor fully. 【NOTE】 - Since the lens position is automatically set into certain position after executing auto adjustment, confirm the angle after stopping the lens zoom position. - It is no problem even though the chart on to the LCD monitor slightly cut at the corner. - It is no problem even though the focusing slightly becomes out of focusing condition. - Not connect the USB cable at this stage.	1)Press Shutter Button 2)After completed, the "OK" message appears.
7	ISO	ISO	ISO sensitivity adjustment	○	○	○		1)Press Shutter Button 2)After completed, the "OK" message appears.	
8	High brightness coloration	LIN	High brightness coloration adjustment	○	○	○		1)Press Shutter Button 2)After completed, the "OK" message appears.	
9	White Balance	WBL	White balance adjustment under various color temperature	○	○	○		1)Press Shutter Button 2)After completed, the "OK" message appears.	
10	CCD Missing Pixels (White)	WKI	Compensation of CCD Missing Pixels (White)	○	—	※1	NONE	NONE	1)Press Shutter Button 2)After completed, the "OK" message appears.
11	Color reproduction inspection and Microphone check	COL	Color reproduction inspection and Microphone check	○	○	○	NONE	NONE	1)Press Shutter Button 2)After completed, the "OK" message appears.
		BKI	Do not use "BKI" adjustment flag for this unit. Use "BK2" adjustment flag, instead. (In case of mostDSC models, the adjustment flag for CCD Missing Pixels is "BKI". But, in this model, "BK2" the adjustment flag for CCD Missing Pixels.)						

Adjustment order	Adjustment Item	FLAG	Purpose	Replacing Parts		JIG/TOOLS	SET UP	How to Operate
				MAIN P.C.B. Lens part (Except CCD U)	CCD UNIT			
12	CCD Missing Pixels (Black)	BK2	Compensation of CCD Missing Pixels (Black)	○	○ ※1	-LIGHT BOX RFKZ0523 (VFK1164TDVLB) -ND FILTER (VFK1164ND15)	1) Prepare the LIGHTBOX (RFKZ0523). (The LIGHTBOX "VFK1164TDVLB" can be used if the front hood of VFK1164TDVLB is removed.) 2) Set the ND Filter (VFK1164ND15) to the LIGHTBOX. 3) Set the LIGHTBOX and Camera unit so that distance becomes about 3 cm. NOTE: Do not use "BK1" adjustment flag for this unit. Use "BK2" adjustment flag, instead.	1) Press Shutter Button. (The lens starts zooming and stops automatically, then green ● mark is displayed on LCD). 2) Aim the LIGHTBOX so that the entire LCD screen becomes fully "white". (No dark area). 3) Press Shutter Button. (The <BK1 adjustment 1> is executed, and then green ● mark is displayed on LCD). 4) Press Shutter Button. (The lens starts zooming and stops automatically, then green ● mark is displayed on LCD). 5) Press Shutter Button. (The <BK1 adjustment 2> is executed, and then green ● mark is displayed on LCD). 6) Press Shutter Button. (The lens starts zooming and stops automatically, then green ● mark is displayed on LCD). 7) Press Shutter Button. (The <BK1 adjustment 3> is executed, and then green ● mark is displayed on LCD). 8) Press Shutter Button. ("OK" mark is displayed on LCD when the adjustment has been completed successfully.)

※1: Execute the adjustment when remove the CCD unit and replace the CCD unit.

※2: The pixel that always lights while shaded is called a white wound.

※3: The pixel that does not light while complete exposed is called a black wound.

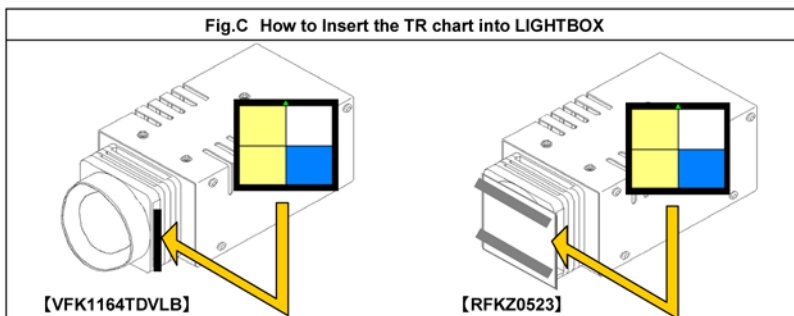
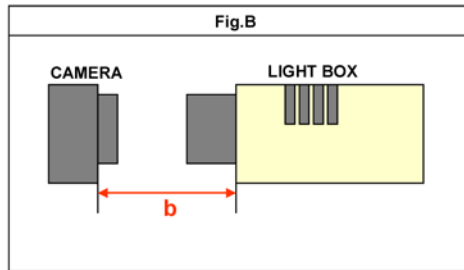
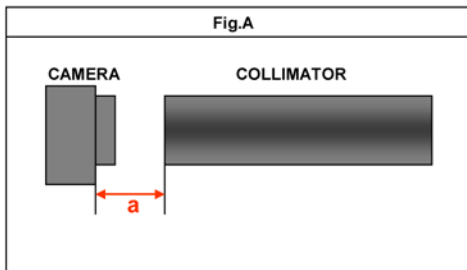

IMPORTANT NOTICE (After replacing the MAIN P.C.B.)
 After replacing the MAIN P.C.B., make sure to perform the "INITIAL SETTINGS" first, then release the "INITIAL SETTINGS" in order to proceed the electrical adjustment.

NOTE:

- 1). If electrical adjustment or data re-writing is executed before "INITIAL SETTINGS", suffix code list is never displayed, and it cannot be chosen suitable suffix code.
- 2). Never remove the battery during initial setting in process.

9.4. After Adjustment

9.4.1. Initial Setting

Since the initial setting has been released to execute the built-in adjustment software, it should be set up again before shipping the camera to the customer.

Refer to the procedure described in “3.5.2. INITIAL SETTINGS” for details.

[IMPORTANT]

1. The initial setting should be done again after completing the alignment. Otherwise, the camera will not work properly.
Therefore as a warning, the camera display a warning symbol “ ! ” on the LCD monitor every time the camera is turned off.
2. Confirm that status of all adjustment flag show “F”. Even if one of the adjustment flag shows “0”, initial setting programmed is never executed.

10 Maintenance

10.1. Cleaning Lens and LCD Panel

Do not touch the surface of lens and LCD Panel with your hand.

When cleaning the lens, use air-Blower to blow off the dust.

When cleaning the LCD Panel, dampen the lens cleaning paper with lens cleaner, and the gently wipe the its surface.

Note:

The Lens Cleaning KIT ; VFK1900BK (Only supplied as 10 set/Box) is available as Service Aid.

Service Manual

Diagrams and Replacement Parts List

Digital Camera

Model No.

DMC-FH5P	DMC-FH5GD	DMC-FS18EB
DMC-FH5PC	DMC-FH5GF	DMC-FS18EE
DMC-FH5PR	DMC-FH5GK	DMC-FS18EF
DMC-FH5PU	DMC-FH5GM	DMC-FS18EG
DMC-FH5GA	DMC-FH5GN	DMC-FS18EP
DMC-FH5GC	DMC-FH5GT	

- Vol. 1
Colour
- (S).....Silver Type (except PC/PR/GD/GT/EF)
 - (K).....Black Type
 - (N).....Gold Type (only P/GK)
 - (P).....Pink Type (except P/PC/PR/EB/EF/EP)
 - (V).....Violet Type (except PR/GA/GC/GD/GF/GM/GT/EP)

Table of contents

S1. About Indication of The Schematic Diagram.....	S-1	S6. Replacement Parts List.....	S-13
S1.1. Important Safety Notice.....	S-1	S7. Exploded View	S-18
S2. Voltage Chart	S-2	S7.1. Frame and Casing Section.....	S-18
S2.1. Flash P.C.B.	S-2	S7.2. Packing Parts and Accessories Section (1)	S-19
S3. Block Diagram.....	S-3	S7.3. Packing Parts and Accessories Section (2)	S-20
S3.1. Overall Block Diagram	S-3		
S3.2. Flash/Top Block Diagram	S-4		
S4. Schematic Diagram.....	S-5		
S4.1. Interconnection Diagram	S-5		
S4.2. Top Schematic Diagram	S-6		
S4.3. Flash Schematic Diagram	S-7		
S4.4. CCD Flex Schematic Diagram	S-8		
S5. Print Circuit Board	S-9		
S5.1. Top P.C.B.	S-9		
S5.2. Flash P.C.B.	S-10		
S5.3. CCD Flex P.C.B.....	S-11		

S1. About Indication of The Schematic Diagram

S1.1. Important Safety Notice

COMPONENTS IDENTIFIED WITH THE MARK \triangle HAVE THE SPECIAL CHARACTERISTICS FOR SAFETY. WHEN REPLACING ANY OF THESE COMPONENTS USE ONLY THE SAME TYPE.

1. Although reference number of the parts is indicated on the P.C.B. drawing and/or schematic diagrams, it is NOT mounted on the P.C.B. when it is displayed with "\$" mark.
2. It is only the "Test Round" and no terminal (Pin) is available on the P.C.B. when the TP (Test Point) indicated as "●" mark.
3. The voltage being indicated on the schematic diagram is measured in "Standard-Playback" mode when there is no specify mode is mentioned.
4. Although the voltage and waveform available on here is measured with standard frame, it may be differ from actual measurement due to modification of circuit and so on.
5. The voltage being indicated here may be include observational-error (deviation) due to internal-resistance and/or reactance of equipment. Therefore, handle the value indicated on here as reference.
6. Use the parts number indicated on the Replacement Parts List .
7. Indication on Schematic diagrams:

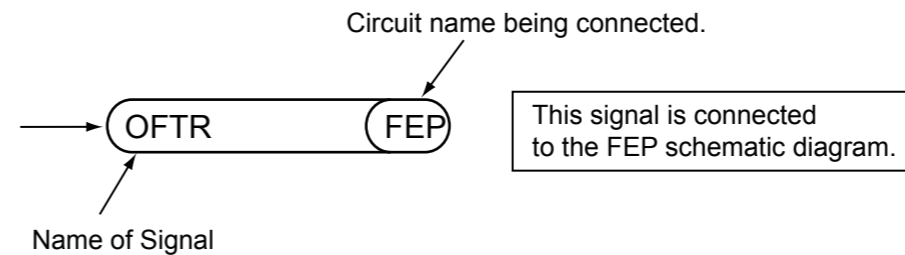

S2. Voltage Chart

Note) Indicated voltage values are the standard values for the unit measured by the DC electronic circuit tester (high-impedance) with the chassis taken as standard.
Therefore, there may exist some errors in the voltage values, depending on the internal impedance of the DC circuit tester.

S2.1. Flash P.C.B.

REF No.	PIN No.	POWER ON
IC8100	1	0
IC8100	2	0
IC8100	3	0
IC8100	4	0
IC8100	5	3.4
IC8100	6	0
IC8100	7	0
IC8100	8	0
IC8100	9	3.1
IC8100	10	3.6

S3. Block Diagram

S3.1. Overall Block Diagram

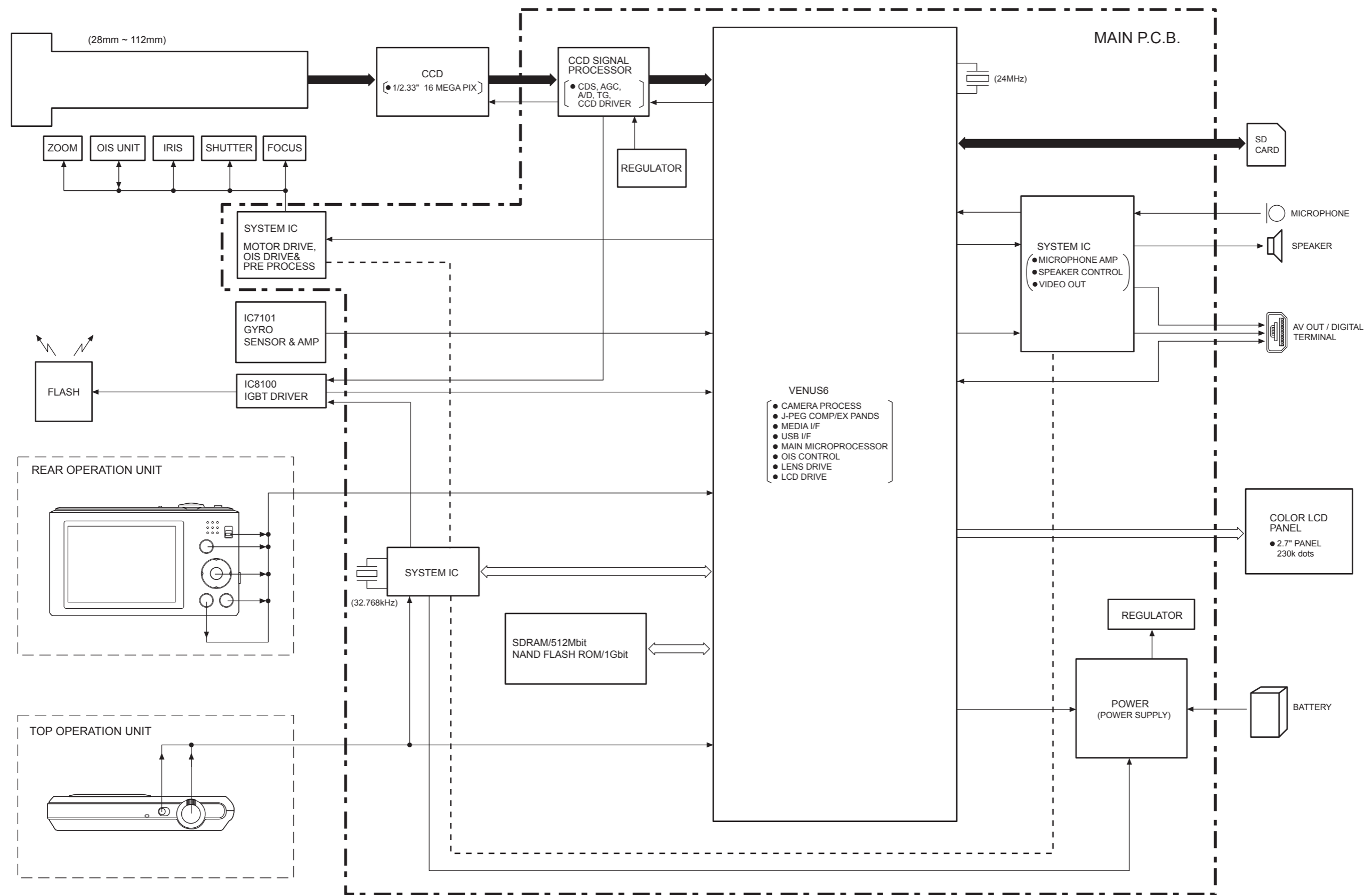

S3.2. Flash/Top Block Diagram

◆ FLASH BLOCK DIAGRAM

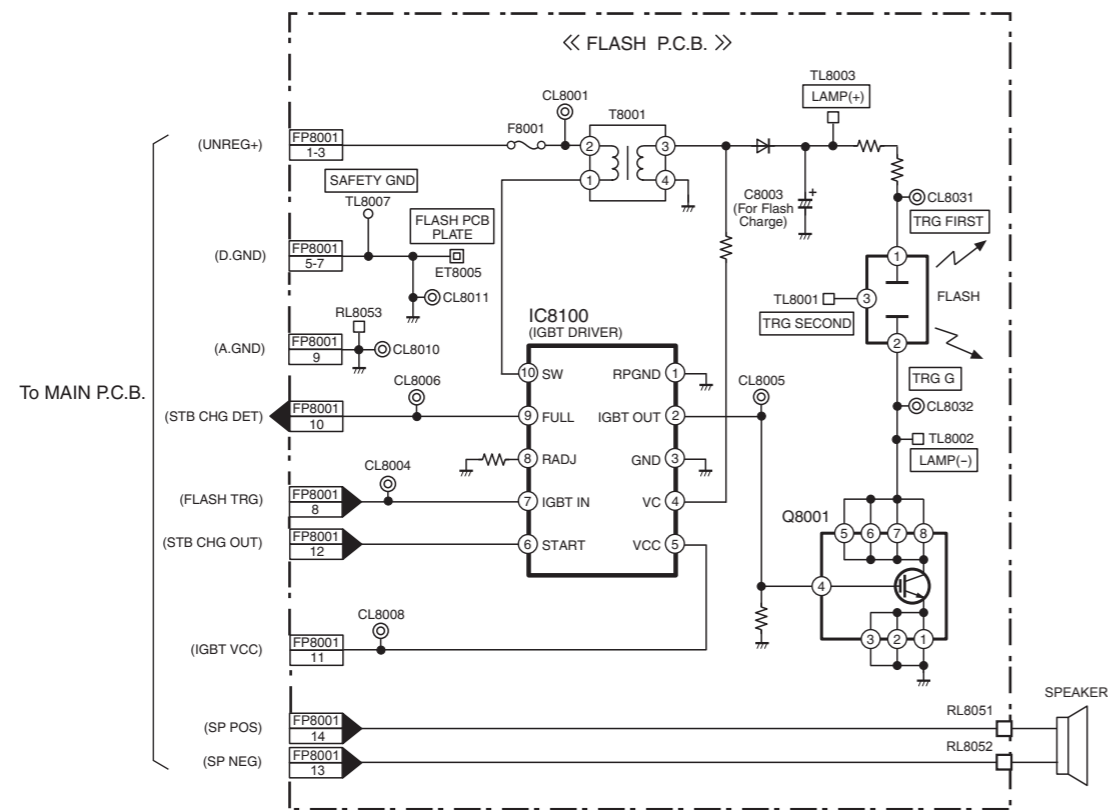

◆ TOP BLOCK DIAGRAM

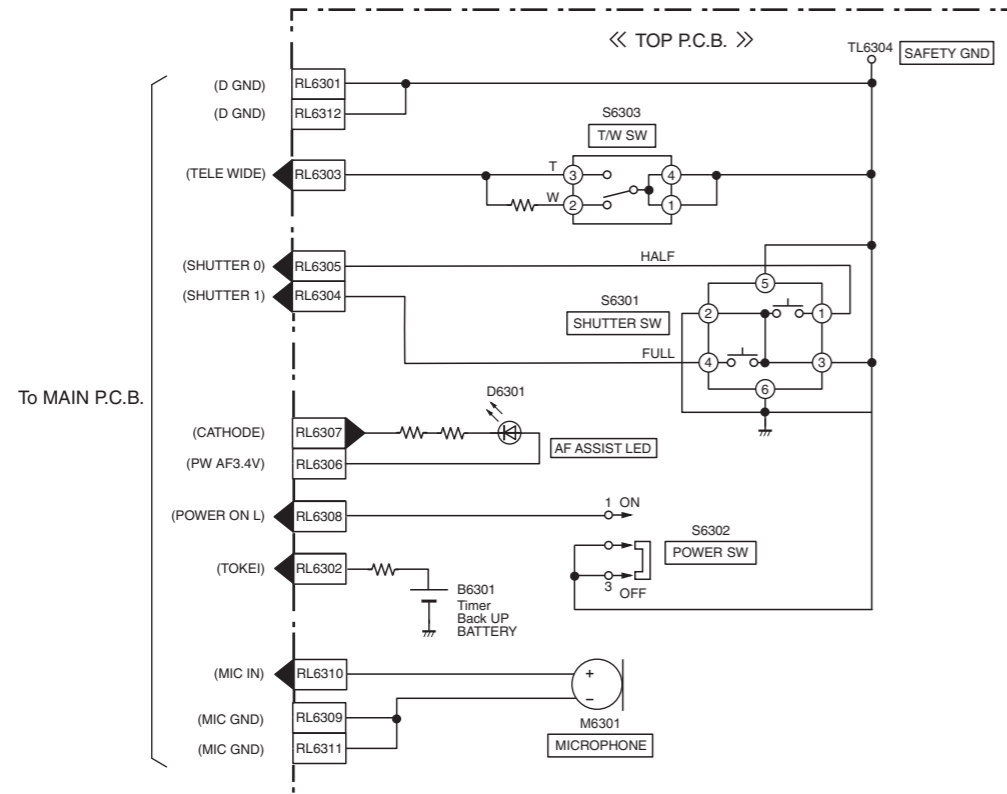

S4. Schematic Diagram

S4.1. Interconnection Diagram

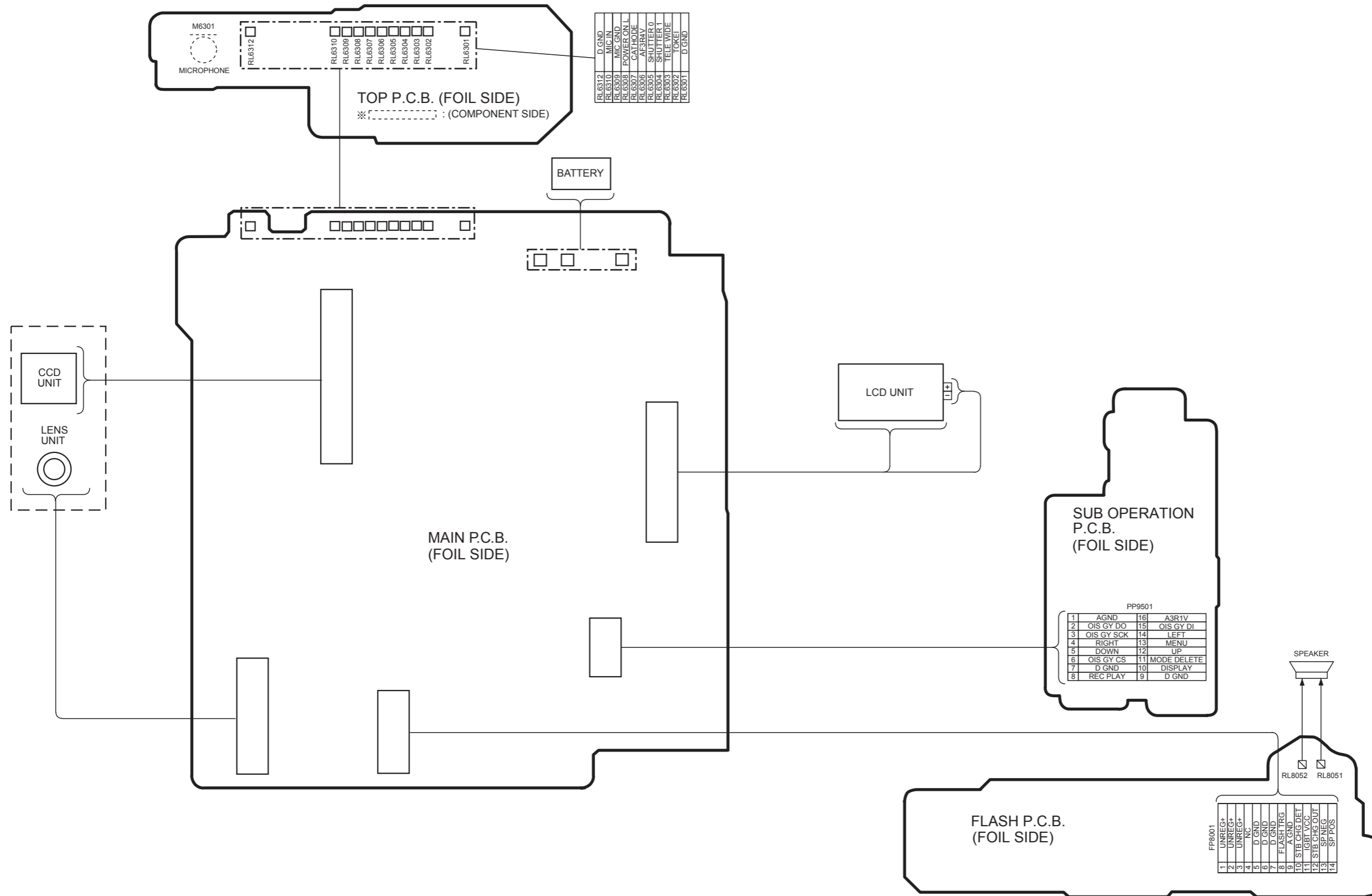

S4.2. Top Schematic Diagram

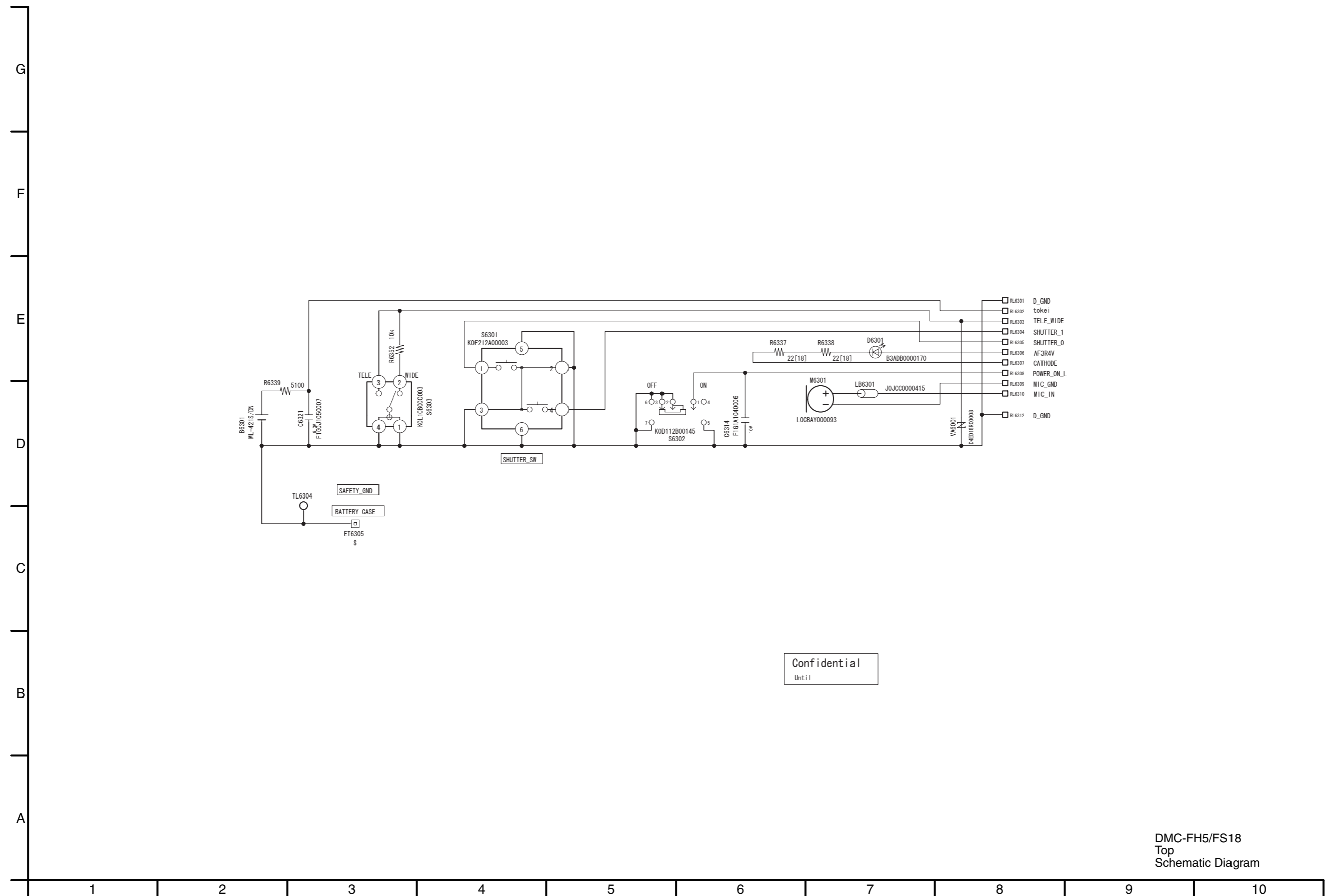

S4.3. Flash Schematic Diagram

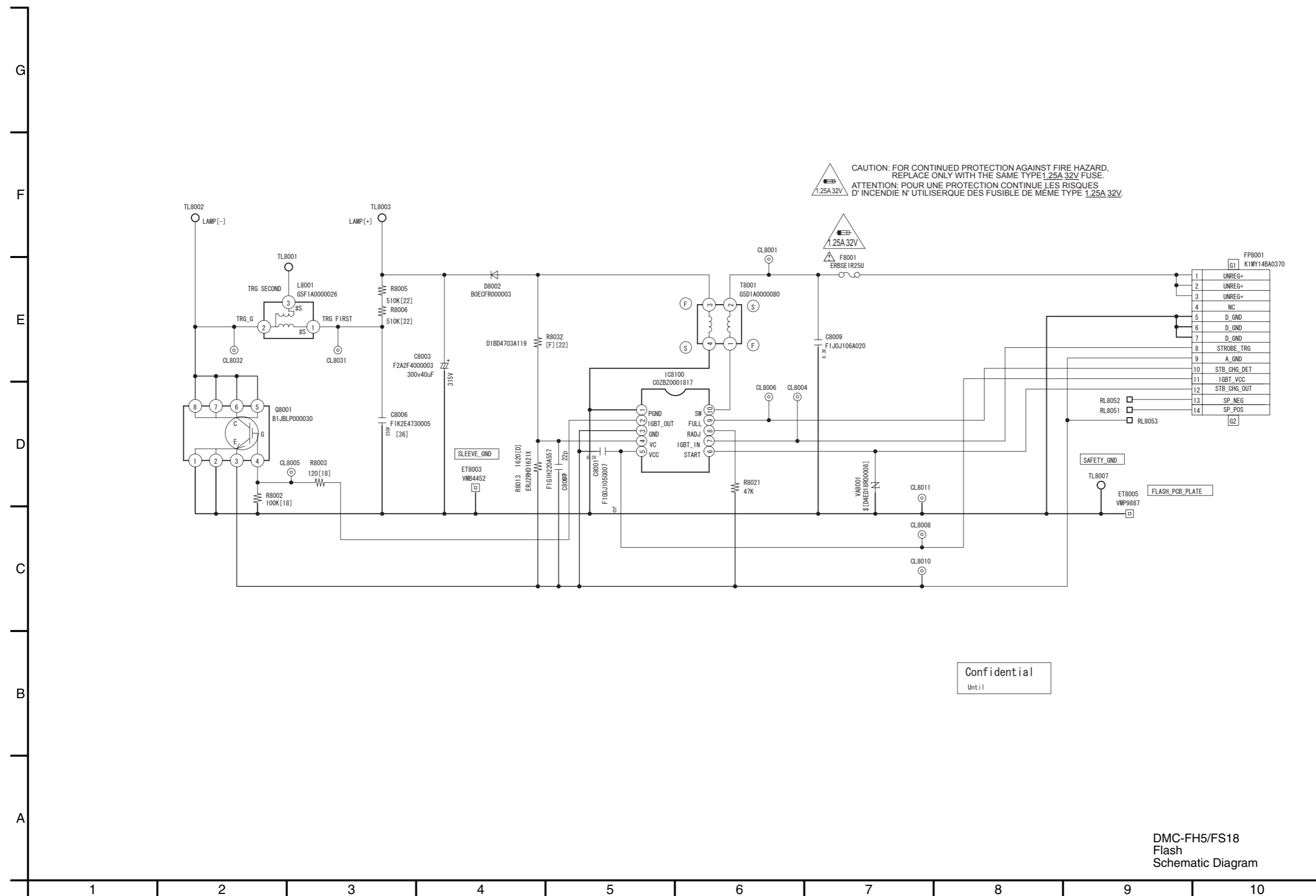

S4.4. CCD Flex Schematic Diagram

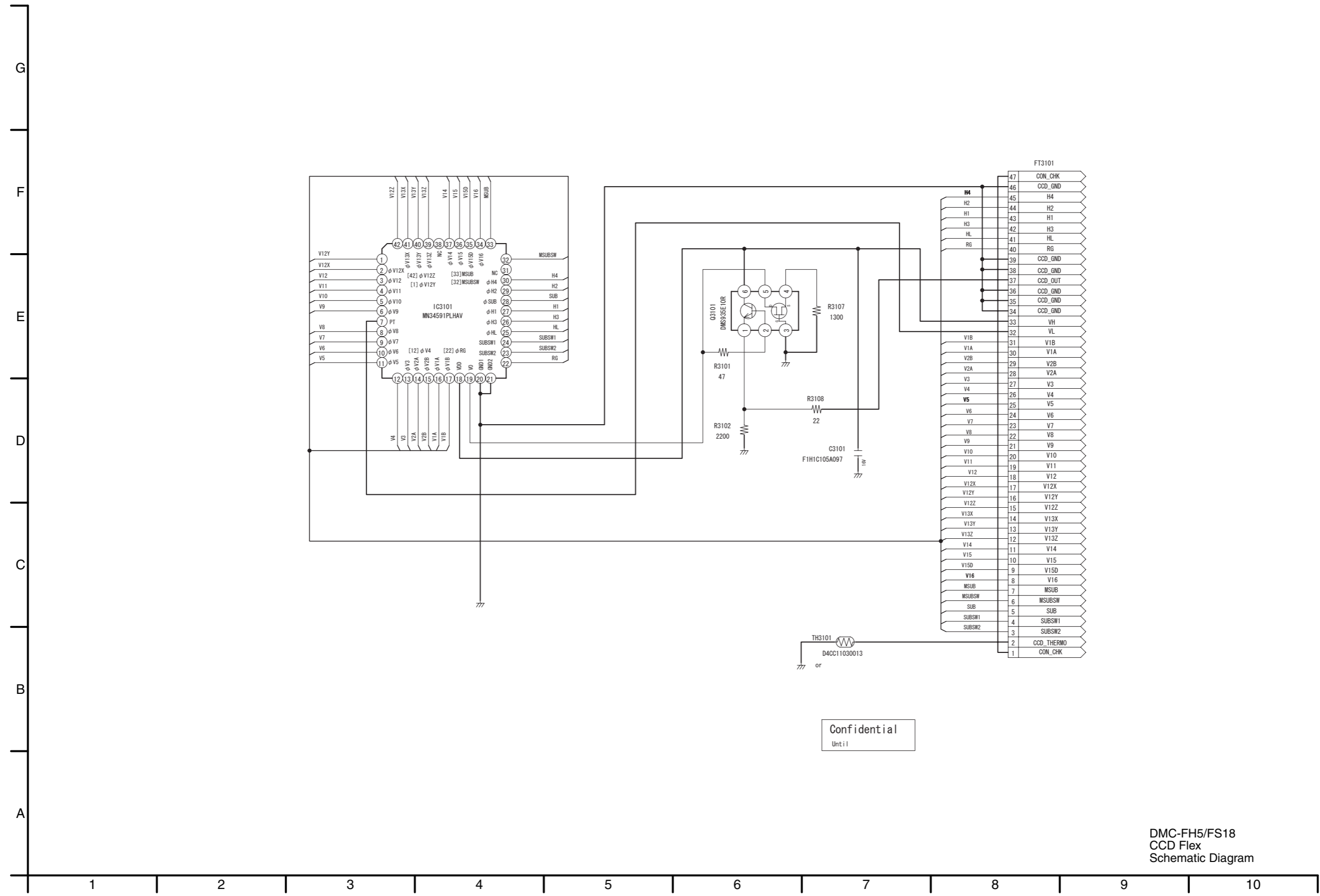

Confidential
Until

S5. Print Circuit Board

S5.1. Top P.C.B.

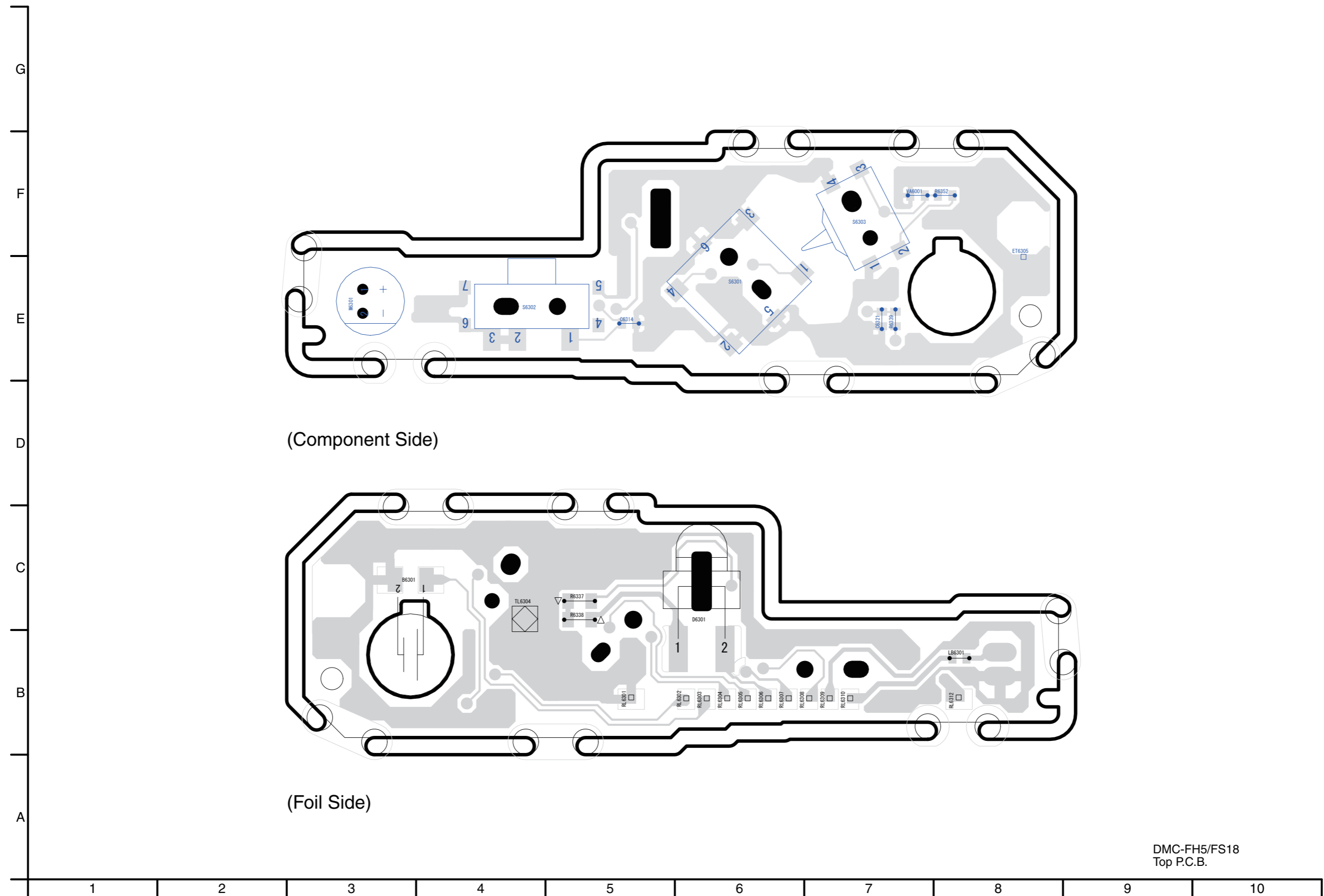

S5.2. Flash P.C.B.

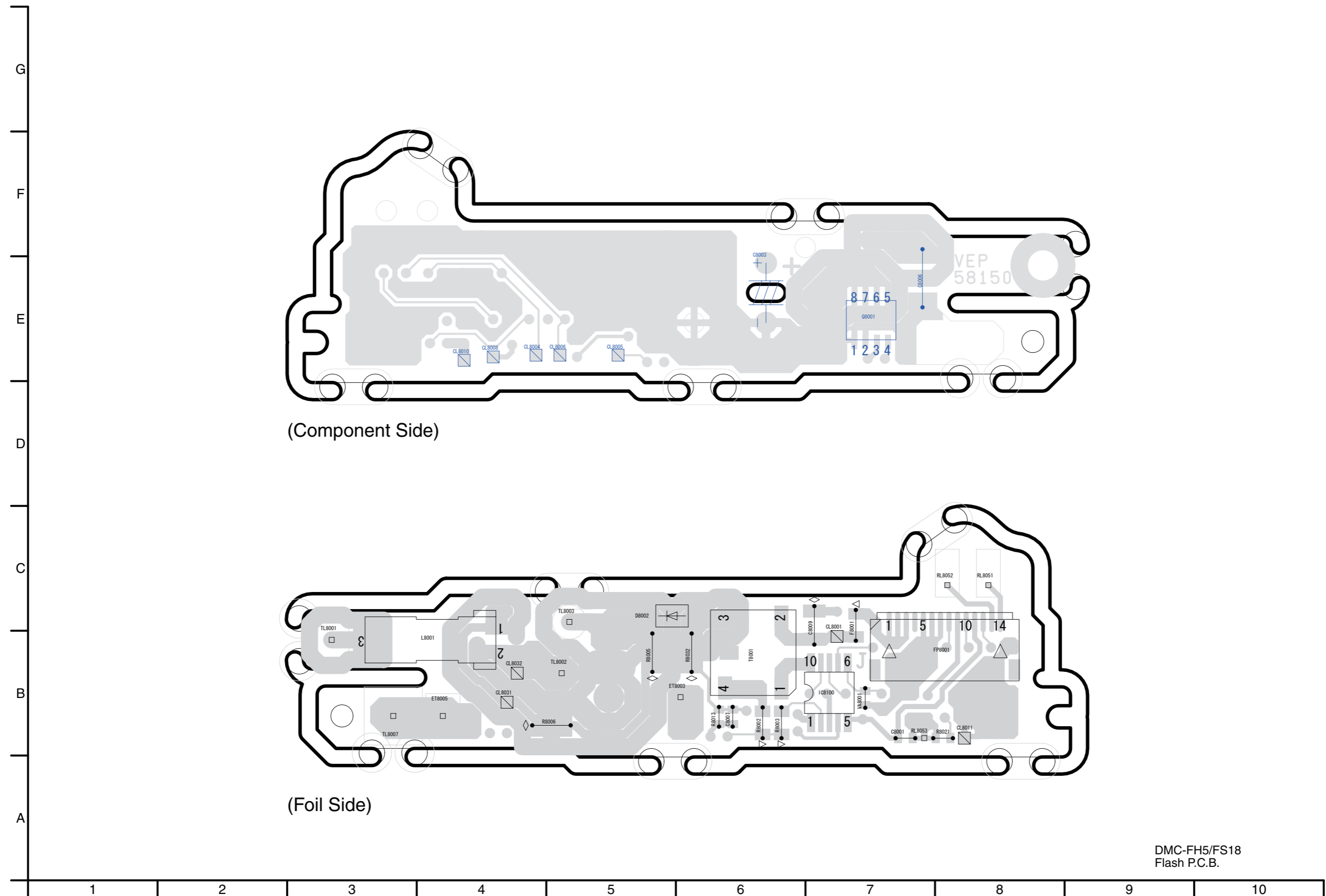

DMC-FH5/FS18
Flash P.C.B.

S5.3. CCD Flex P.C.B.

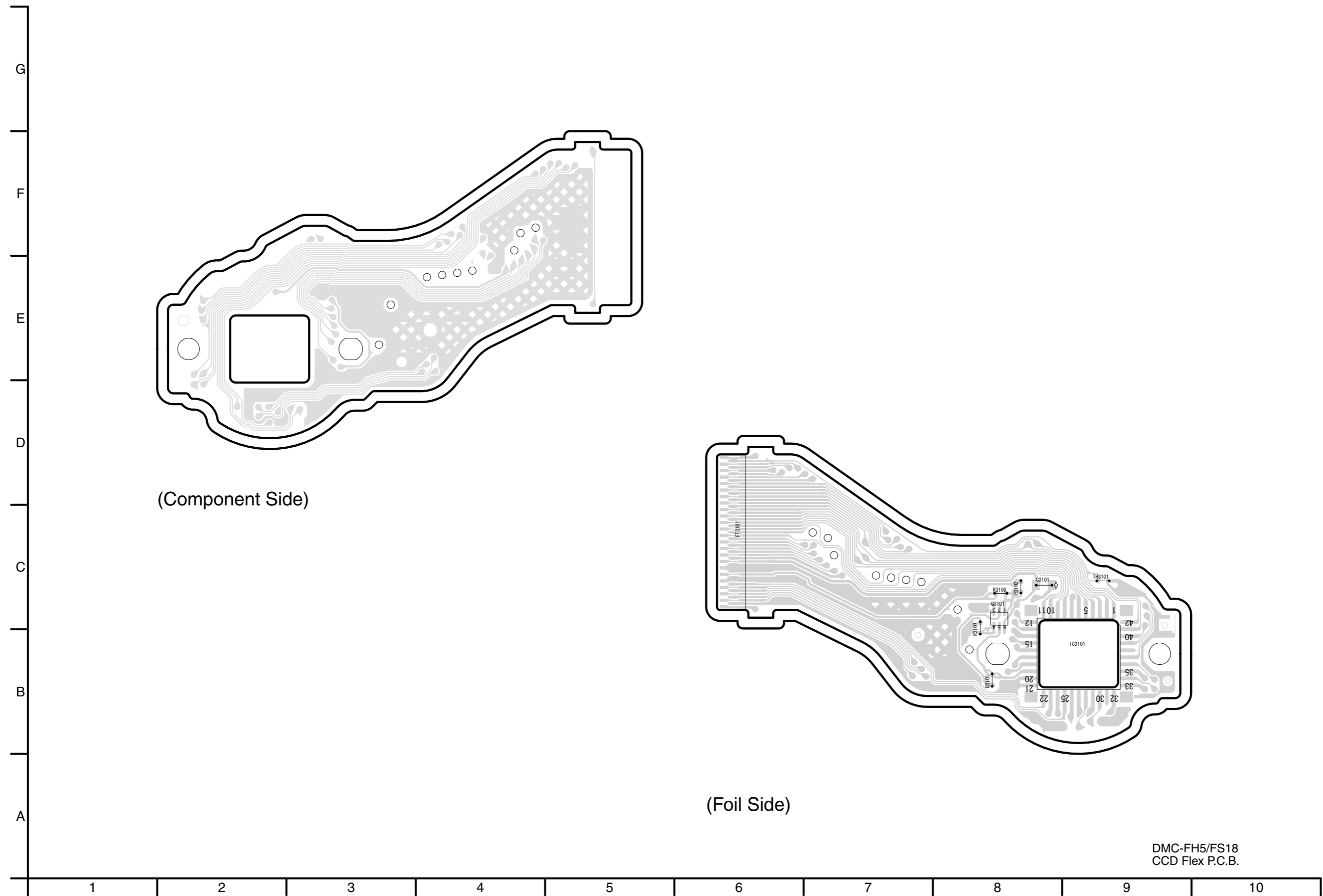

DMC-FH5/FS18
CCD Flex P.C.B.

S6. Replacement Parts List

- Note:
1. * Be sure to make your orders of replacement parts according to this list.
 2. **IMPORTANT SAFETY NOTICE**
Components identified with the mark \triangle have the special characteristics for safety.
When replacing any of these components, use only the same type.
 3. Unless otherwise specified,
All resistors are in OHMS, K=1,000 OHMS. All capacitors are in MICRO-FARADS (uf), P=uuF.
 4. The marking (RTL) indicates the retention time is limited for this item. After the discontinuation of this assembly in production, it will no longer be available.
 5. Supply of CD-ROM, in accordance with license protection, is allowable as replacement parts only for customers who accidentally damaged or lost their own.

E.S.D. standards for Electrostatically Sensitive Devices, refer to PREVENTION OF ELECTROSTATIC DISCHARGE (ESD) TO ELECTROSTATICALLY SENSITIVE (ES) DEVICES section.

Definition of Parts supplier:

1. Parts marked with [ENERGY] in the remarks column are supplied from Panasonic Corporation Energy Company.
2. Parts marked with [SPC] in the remarks column are supplied from AVC-CSC-SPC. Others are supplied from PAVCSG.

DMC-FS18EG-S

Ref.No.	Part No.	Part Name & Description	Pcs	Remarks	Ref.No.	Part No.	Part Name & Description	Pcs	Remarks
1	VEP50081A	SUB OPERATION P.C.B.	1	(RTL) E.S.D.	100	VXW1249	LENS UNIT (W/O CCD)	1	
2	VEP56127A	MAIN P.C.B.	1	E.S.D.	101	VEK0R39	CCD UNIT	1	
3	VEP58150A	FLASH P.C.B.	1	(RTL) E.S.D.					
4	VEP58151A	TOP P.C.B.	1	(RTL) E.S.D.					
5	L0AA01A00102	SPEAKER	1						
6	VGK3726	SIDE ORNAMENT R	1		B1	VHD2205	SCREW	1	
7	VMP9890	FRAME PLATE A	1		B2	VHD2205	SCREW	1	
8	VYK5C93	LCD UNIT	1		B3	VHD2205	SCREW	1	(-S,-N,-P,-V)
8-1	VYP9332	LCD PANEL UNIT	1		B3	VHD2206	SCREW	1	(-K)
9	B3ADB0000170	AF LED	1	(D6301) E.S.D.	B4	VHD2205	SCREW	1	(-S,-N,-P,-V)
10	EFN-AMC.J5ZD	FLASH UNIT	1		B4	VHD2206	SCREW	1	(-K)
△ 11	F2A2F4000003	E.CAPACITOR	1	(C8003)	B5	VHD2205	SCREW	1	(-S,-N,-P,-V)
12	L0CBAY000093	MICROPHONE UNIT	1	(M6301)	B5	VHD2206	SCREW	1	(-K)
△ 13	ML-421S/DN	BATTERY	1	[ENERGY] (B6301)	B6	VHD2205	SCREW	1	(-S,-N,-P,-V)
14	VGK3738	FRONT ORNAMENT	1		B6	VHD2206	SCREW	1	(-K)
15	VGL1365	AF PANEL LIGHT	1		B7	VHD2290	SCREW	1	(-S,-N,-P,-V)
16	VGQ0S42	CONDENSER SHEET	1		B7	VHD2300	SCREW	1	(-K)
17	VGQ0T93	TERMINAL SHEET	1		B8	VHD2290	SCREW	1	(-S,-N,-P,-V)
18	VGQ0U65	SP SHEET	1		B8	VHD2300	SCREW	1	(-K)
19	VGQ0V71	TOP PCB SHEET	1		B9	VHD1759	SCREW	1	
20	VGQ0V90	DPR SHEET A	1		B10	VHD1759	SCREW	1	
21	VGQ0V91	DPR SHEET B	1		B11	VHD1759	SCREW	1	
23	VKF4797	JACK DOOR	1	(-S)	B12	VHD2004	SCREW	1	
23	VKF4813	JACK DOOR	1	(-K)	B13	VHD2205	SCREW	1	
23	VKF4847	JACK DOOR	1	(-N)	B14	VHD2210	SCREW	1	
23	VKF4815	JACK DOOR	1	(-V)	B15	VHD2302	SCREW	1	
23	VKF4814	JACK DOOR	1	(-P)	B16	VHD2302	SCREW	1	
24	VMB4452	EARTH SPRING	1	(ET8003)	B100	VHD1871	SCREW	1	
25	VMP9887	FLASH PCB PLATE	1	(ET8005)	B101	VHD1871	SCREW	1	
26	VMT2136	MIC DUMPER	1		B102	VHD1871	SCREW	1	
27	VMT2137	IRIS DUMPER	1						
28	VWJ2251	FLASH FPC	1						
29	VYK4P52	BATTERY DOOR UNIT	1	(-S)					
29	VYK4P98	BATTERY DOOR UNIT	1	(-K)					
29	VYK4Q90	BATTERY DOOR UNIT	1	(-N)					
29	VYK4Q89	BATTERY DOOR UNIT	1	(-V)					
29	VYK4Q88	BATTERY DOOR UNIT	1	(-P)					
29-1	VMB4143	BATTERY DOOR SPRING	1						
29-2	VMS7863-A	BATTERY DOOR SHAFT	1						
30	K4ZZ01000292	OTHER TERMINALS	1						
31	K4ZZ01000292	OTHER TERMINALS	1						
32	K4ZZ01000292	OTHER TERMINALS	1						
33	VGU0H52	BATTERY LOCK KNOB	1						
34	VMB4152-A	BATTERY LOCK SPRING	1						
35	VMB4450	BATTERY OUT SPRING	1						
36	VMP9888	FRAME	1						
37	VMP9889	BATTERY CASE	1						
38	VYK4Q30	FRONT CASE UNIT	1	P-S					
38	VYK4Q31	FRONT CASE UNIT	1	P-K					
38	VYK4Q35	FRONT CASE UNIT	1	P-N					
38	VYK4Q34	FRONT CASE UNIT	1	P-V					
38	VYK4Q66	FRONT CASE UNIT	1	PC-K,PU-K,PR-K,GC-K,GM-K, GF-K,GA-K,GT-K,GK-K, GN-K,GD-K,EG-K,EP-K, EF-K,EB-K,EE-K					
38	VYK4Q72	FRONT CASE UNIT	1	PC-V,PU-V,GK-V,GN-V,EG-V, EF-V,EB-V,EE-V					
38	VYK4P53	FRONT CASE UNIT	1	PU-S,GC-S,GM-S,GF-S, GA-S,GK-S,GN-S,EG-S, EP-S,EB-S,EE-S					
38	VYK4Q69	FRONT CASE UNIT	1	(-P)					
38	VYK4Q73	FRONT CASE UNIT	1	GK-N					
39	VYK4P54	REAR CASE UNIT	1	(-S)					
39	VYK4Q80	REAR CASE UNIT	1	(-K)					
39	VYK4Q85	REAR CASE UNIT	1	(-N)					
39	VYK4Q84	REAR CASE UNIT	1	(-V)					
39	VYK4Q82	REAR CASE UNIT	1	(-P)					
39-1	VGU0H59	CURSOR BUTTON A	1						
39-2	VGU0H60	MENU SET BUTTON A	1						
40	VYK4P55	TOP CASE UNIT	1	(DMC-FH5)					
40	VYK4P97	TOP CASE UNIT	1	(DMC-FS18)					
40-1	VGU0H63	POWER KNOB	1						
41	VGQ0S04	PCB SPACER	1						
42	VGU0H61	MODE KNOB	1						
45	VGQ0W28	COIL CUSHION	1						

DMC-FS18EG-S

Ref.No.	Part No.	Part Name & Description	Pcs	Remarks
	300	VPF1372-A	CAMERA BAG	1 EXCEPT P,PC,PU
△	301	DE-A92DA/SX	BATTERY CHARGER	1 PR
△	301	DE-A92BA/SX	BATTERY CHARGER	1 GM,GF,GA,GK,GD
△	301	DE-A92CA/SX	BATTERY CHARGER	1 GT
△	301	DE-A92AA/SX	BATTERY CHARGER	1 GN,EG,EP,EF,EB,EE
△	301	DE-A92BA	BATTERY CHARGER	1 GC [SPC]
△	302	-----	BATTERY	1 EXCEPT P,PC,PU
	304	K1HY08YY0015	USB CABLE W/PLUG	1 EXCEPT P,PC,PU
	305	K1HY08YY0016	AV CABLE W/PLUG	1 EXCEPT P,PC,PU
	306	VFC4297-B	HAND STRAP	1 EXCEPT P,PC,PU
△	307	VFF0729-S	CD-ROM	1 GM,GF,GA,GT,GN,GD
			(SOFT/INSTRUCTION BOOK)	[SPC] See "Notes"
△	307	VFF0730-S	CD-ROM	1 GK
			(SOFT/INSTRUCTION BOOK)	[SPC] See "Notes"
△	307	VFF0727-S	CD-ROM	1 EG,EP,EF,EB
			(SOFT/INSTRUCTION BOOK)	[SPC] See "Notes"
△	307	VFF0728-S	CD-ROM	1 EE
			(SOFT/INSTRUCTION BOOK)	[SPC] See "Notes"
△	307	VFF0726-S	CD-ROM	1 PR
			(SOFT/INSTRUCTION BOOK)	[SPC] See "Notes"
△	307	VFF0794-S	CD-ROM	1 GC
			(SOFT/INSTRUCTION BOOK)	[SPC] See "Notes"
	309	VPF1378	BAG, POLYETHYLENE	1 EXCEPT P,PC,PU
	310	VQC8062	O/I SOFTWARE	1 GC,GM,GF,GA
			(ENGLISH/	
			CHINESE(TRADITIONAL)/	
			ARABIC/PERSIAN)	
	310	VQC8063	O/I SOFTWARE	1 GT
			(CHINESE(TRADITIONAL))	
	310	VQC8064	O/I SOFTWARE	1 GK
			(CHINESE(SIMPLIFIED))	
	310	VQC8060	O/I SOFTWARE	1 GN,EB
			(ENGLISH)	
	310	VQC8068	O/I SOFTWARE	1 GD
			(KOREAN)	
	310	VQC8057	O/I SOFTWARE	1 EG
			(GERMAN/FRENCH/ITALIAN/	
			DUTCH/SPANISH/	
			PORTUGUESE/TURKISH)	
	310	VQC8058	O/I SOFTWARE	1 EP
			(SWEDISH/DANISH/POLISH/	
			CZECH/HUNGARIAN/FINNISH)	
	310	VQC8059	O/I SOFTWARE	1 EF
			(FRENCH)	
	310	VQC8061	O/I SOFTWARE	1 EE
			(RUSSIAN/UKRAINIAN)	
	310	VQC8056	O/I SOFTWARE	1 PR
			(SPANISH/PORTUGUESE)	
△	311	VQT3D32	BASIC O/I	1 PR-K
			(SPANISH)	
△	311	VQT3D43	BASIC O/I	1 GC,GM,GF,GA
			(ENGLISH/	
			CHINESE(TRADITIONAL))	
△	311	VQT3M09	BASIC O/I	1 GA
			(VIETNAMESE)	
△	311	VQT3D44	BASIC O/I	1 GC,GF
			(ARABIC/PERSIAN)	
△	311	VQT3D45	BASIC O/I	1 GT
			(CHINESE(TRADITIONAL))	
△	311	VQT3D46	BASIC O/I	1 GK
			(CHINESE(SIMPLIFIED))	
△	311	VQT3D47	BASIC O/I	1 GN
			(ENGLISH)	
△	311	VQT3F53	BASIC O/I	1 GD
			(KOREAN)	
△	311	VQT3D33	BASIC O/I	1 EG
			(GERMAN/FRENCH)	
△	311	VQT3D34	BASIC O/I	1 EG
			(ITALIAN/DUTCH)	
△	311	VQT3D35	BASIC O/I	1 EG
			(SPANISH/PORTUGUESE)	
△	311	VQT3D36	BASIC O/I	1 EG
			(TURKISH)	
△	311	VQT3D37	BASIC O/I	1 EP
			(SWEDISH/DANISH)	

Ref.No.	Part No.	Part Name & Description	Pcs	Remarks
△	311	VQT3D38	BASIC O/I	1 EP
			(POLISH/CZECH)	
△	311	VQT3D39	BASIC O/I	1 EP
			(HUNGARIAN/FINNISH)	
△	311	VQT3D40	BASIC O/I	1 EF
			(FRENCH)	
△	311	VQT3D41	BASIC O/I	1 EB
			(ENGLISH)	
△	311	VQT3D42	BASIC O/I	1 EE
			(RUSSIAN/UKRAINIAN)	
	312	VPK4819	PACKING CASE	1 PR-K,GM-K,GA-K,GT-K,GN-K
	312	VPK4819	PACKING CASE	1 GD-K
				Please use the attached Ref No.315 (GD LABEL)
	312	VPK4812	PACKING CASE	1 GM-S,GA-S,GN-S
	312	VPK4826	PACKING CASE	1 GM-P,GA-P,GT-P,GN-P
	312	VPK4826	PACKING CASE	1 GD-P
				Please use the attached Ref No.315 (GD LABEL)
	312	VPK4813	PACKING CASE	1 GF-S
	312	VPK4820	PACKING CASE	1 GF-K
	312	VPK4827	PACKING CASE	1 GF-P
	312	VPK4814	PACKING CASE	1 GK-S
	312	VPK4821	PACKING CASE	1 GK-K
	312	VPK4840	PACKING CASE	1 GK-N
	312	VPK4828	PACKING CASE	1 GK-P
	312	VPK4835	PACKING CASE	1 GK-V
	312	VPK4833	PACKING CASE	1 GN-V
	312	VPK4811	PACKING CASE	1 EG-S,EP-S,EB-S,EE-S
	312	VPK4818	PACKING CASE	1 EG-K,EP-K,EF-K,EB-K,EE-K
	312	VPK4825	PACKING CASE	1 EG-P,EE-P
	312	VPK4832	PACKING CASE	1 EG-V,EF-V,EB-V,EE-V
	312	VPK4908	PACKING CASE	1 GC-S [SPC]
	312	VPK4909	PACKING CASE	1 GC-K [SPC]
	312	VPK4910	PACKING CASE	1 GC-P [SPC]
	313	VPN7175	CUSHION	1 EXCEPT P,PC,PU
	315	VQL2J61	GD LABEL	1 GD
	316	VQL2C68-1A	TAIWAN OPE LABEL	1 GT
△	351	K2CA2YY00129	AC CORD	1 GT
△	351	K2CA2YY00130	AC CORD	1 GK
△	352	K2CJ2YY00052	AC CORD	1 GN
△	353	K2CJ2YY00053	AC CORD	1 PR-K
△	354	K2CQ2YY00082	AC CORD	1 GF,GA,EG,EP,EF,EE
△	354	K2CR2YY00026	AC CORD	1 GD
△	356	K2CT3YY00034	AC CORD	1 GM,EB
△	356	K2CT39A00002	AC CORD	1 GC [SPC]

S7. Exploded View

S7.1. Frame and Casing Section

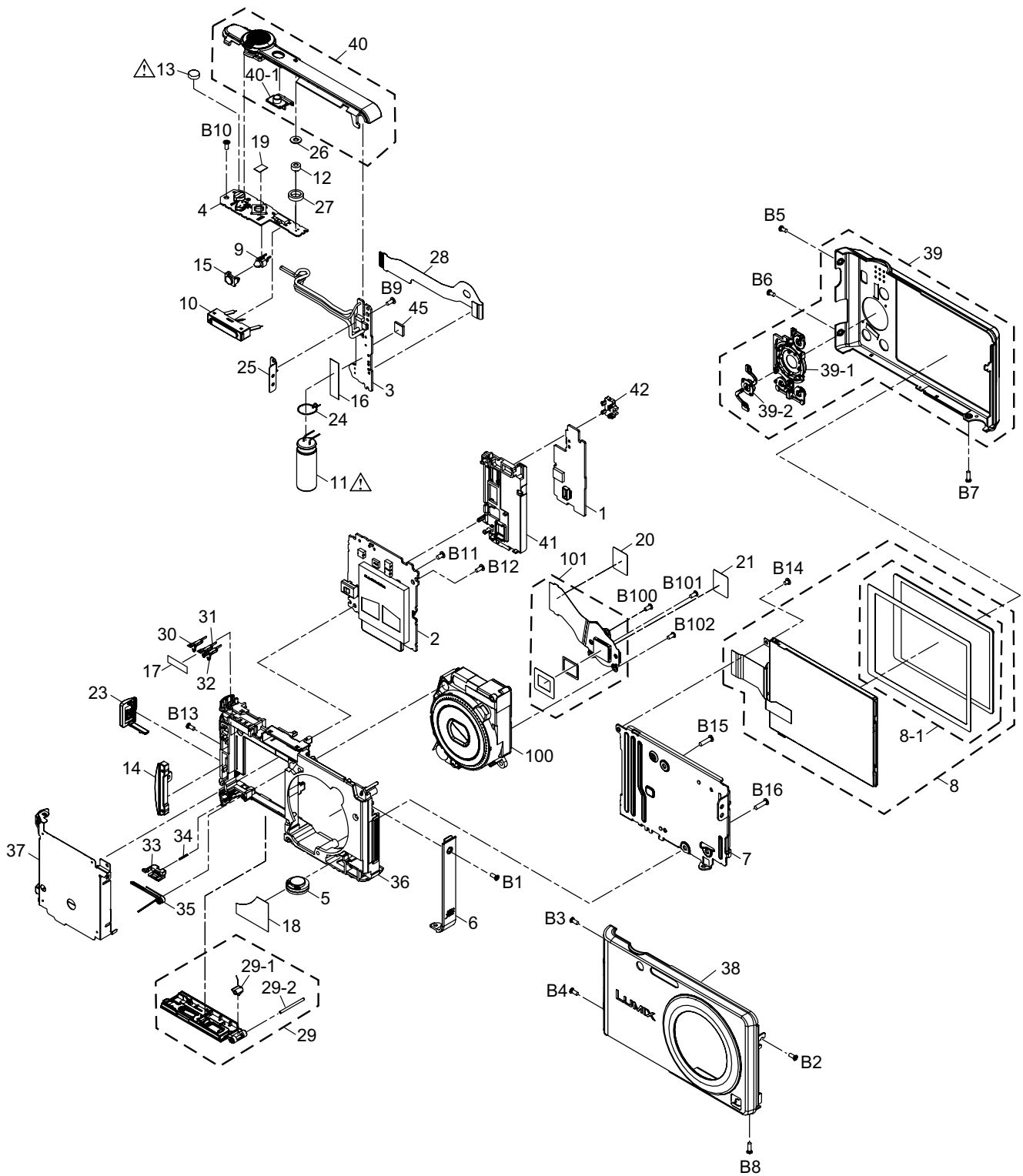

S7.2. Packing Parts and Accessories Section (1)

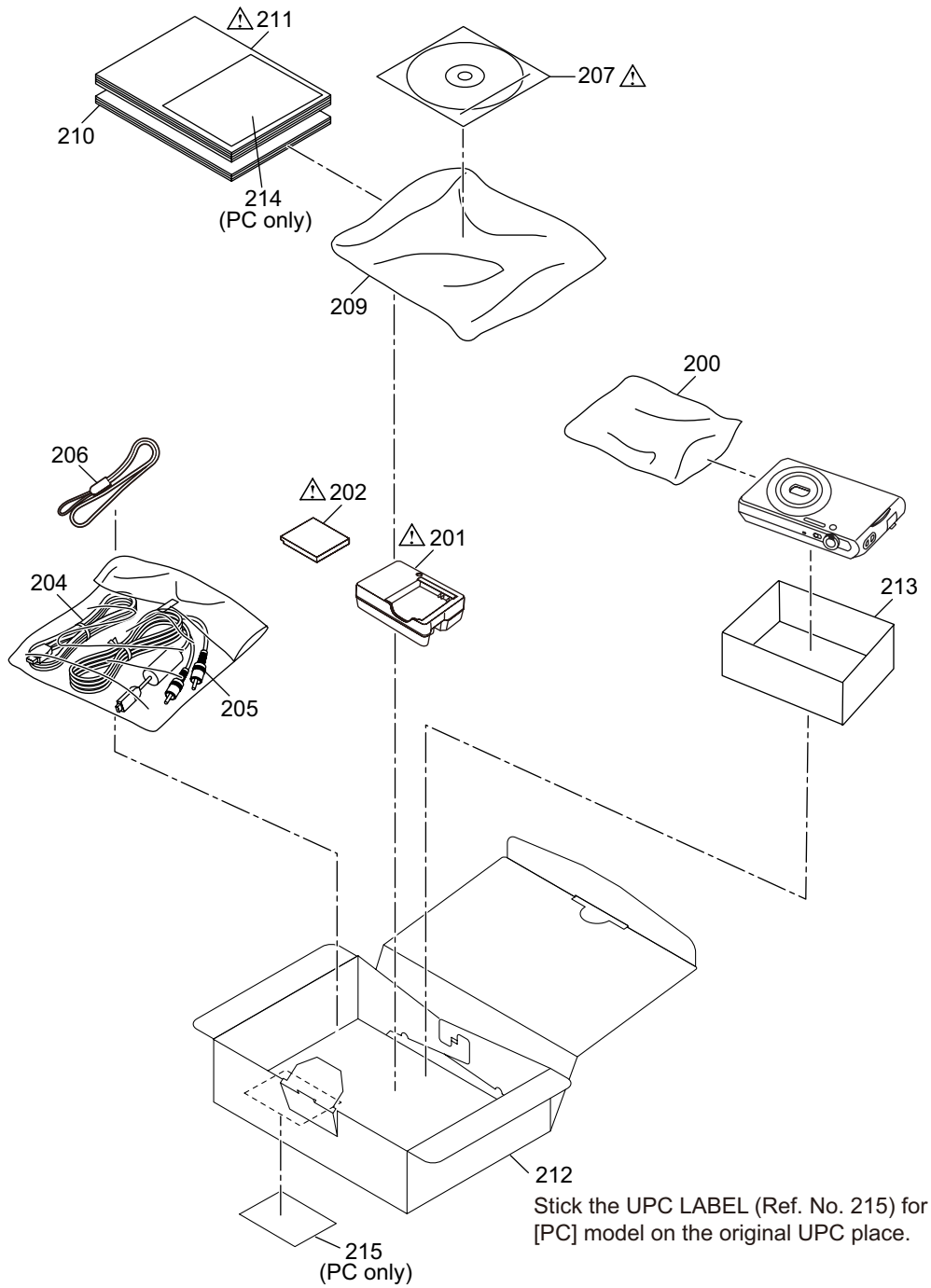

S7.3. Packing Parts and Accessories Section (2)

