

# Service Manual

Digital Camera

LUMIX

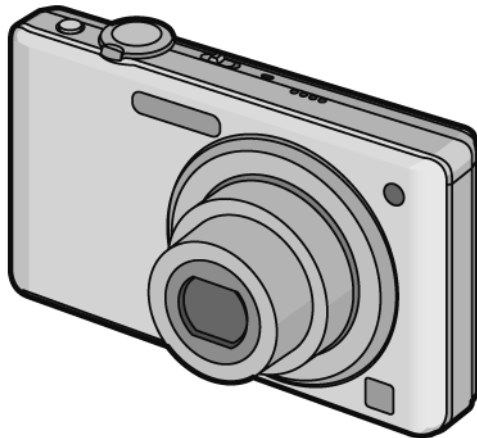

Model No. **DMC-FS15P**  
**DMC-FS15PC**  
**DMC-FS15PR**  
**DMC-FS15PU**  
**DMC-FS15EB**  
**DMC-FS15EE**  
**DMC-FS15EF**  
**DMC-FS15EG**  
**DMC-FS15EP**  
**DMC-FS15GC**  
**DMC-FS15GJ**  
**DMC-FS15GK**  
**DMC-FS15GN**  
**DMC-FS15GT**

Vol. 1

Colour

(S).....Silver Type (except PC/PR/EF/GJ)

(K).....Black Type

(A).....Blue Type (except PR/EF/GJ/GK/GN/GT)

## **WARNING**

This service information is designed for experienced repair technicians only and is not designed for use by the general public. It does not contain warnings or cautions to advise non-technical individuals of potential dangers in attempting to service a product. Products powered by electricity should be serviced or repaired only by experienced professional technicians. Any attempt to service or repair the product or products dealt with in this service information by anyone else could result in serious injury or death.

**Panasonic**<sup>®</sup>

© Panasonic Corporation 2009. Unauthorized copying and distribution is a violation of law.

# TABLE OF CONTENTS

	PAGE	PAGE
<b>1 Safety Precaution</b> .....	<b>3</b>	
1.1. General Guidelines .....	3	
1.2. Leakage Current Cold Check .....	3	
1.3. Leakage Current Hot Check (See Figure 1.) .....	3	
1.4. How to Discharge the Capacitor on Flash Top PCB .....	4	
<b>2 Warning</b> .....	<b>5</b>	
2.1. Prevention of Electrostatic Discharge (ESD) to Electrostatically Sensitive (ES) Devices .....	5	
2.2. How to Recycle the Lithium Ion Battery (U.S. Only) .....	5	
2.3. Caution for AC Cord(For EB/GC) .....	6	
2.4. How to Replace the Lithium Battery .....	7	
<b>3 Service Navigation</b> .....	<b>8</b>	
3.1. Introduction .....	8	
3.2. General Description About Lead Free Solder (PbF) .....	8	
3.3. Important Notice 1:(Other than U.S.A. and Canadian Market) .....	8	
3.4. How to Define the Model Suffix (NTSC or PAL model) .....	9	
<b>4 Specifications</b> .....	<b>13</b>	
<b>5 Location of Controls and Components</b> .....	<b>14</b>	
<b>6 Service Mode</b> .....	<b>16</b>	
6.1. Error Code Memory Function .....	16	
<b>7 Service Fixture &amp; Tools</b> .....	<b>19</b>	
7.1. Service Fixture and Tools .....	19	
7.2. When Replacing the Main PCB .....	20	
7.3. Service Position .....	20	
<b>8 Disassembly and Assembly Instructions</b> .....	<b>21</b>	
8.1. Disassembly Flow Chart .....	21	
8.2. PCB Location .....	21	
8.3. Disassembly Procedure .....	22	
8.4. Disassembly Procedure for the Lens .....	27	
8.5. Assembly Procedure for the Lens .....	29	
8.6. Removal of the CCD Unit .....	31	
8.7. Removal of the Focus Motor Unit .....	32	
8.8. The Applymt of Grease Method .....	32	
<b>9 Measurements and Adjustments</b> .....	<b>33</b>	
9.1. Matrix Chart for Replaced Part and Necessary Adjustment .....	33	
<b>10 Maintenance</b> .....	<b>34</b>	
10.1. Cleaning Lens and LCD Panel .....	34	

# 1 Safety Precautions

## 1.1. General Guidelines

### 1. IMPORTANT SAFETY NOTICE

There are special components used in this equipment which are important for safety. These parts are marked by

 in the Schematic Diagrams, Circuit Board Layout, Exploded Views and Replacement Parts List. It is essential that these critical parts should be replaced with manufacturer's specified parts to prevent X-RADIATION, shock, fire, or other hazards. Do not modify the original design without permission of manufacturer.

2. An Isolation Transformer should always be used during the servicing of AC Adaptor whose chassis is not isolated from the AC power line. Use a transformer of adequate power rating as this protects the technician from accidents resulting in personal injury from electrical shocks. It will also protect AC Adaptor from being damaged by accidental shorting that may occur during servicing.
3. When servicing, observe the original lead dress. If a short circuit is found, replace all parts which have been overheated or damaged by the short circuit.
4. After servicing, see to it that all the protective devices such as insulation barriers, insulation papers shields are properly installed.
5. After servicing, make the following leakage current checks to prevent the customer from being exposed to shock hazards.

## 1.2. Leakage Current Cold Check

1. Unplug the AC cord and connect a jumper between the two prongs on the plug.
2. Measure the resistance value, with an ohmmeter, between the jumpered AC plug and each exposed metallic cabinet part on the equipment such as screwheads, connectors, control shafts, etc. When the exposed metallic part has a return path to the chassis, the reading should be between  $1\text{ M}\Omega$  and  $5.2\text{ M}\Omega$ . When the exposed metal does not have a return path to the chassis, the reading must be infinity.

## 1.3. Leakage Current Hot Check (See Figure 1.)

1. Plug the AC cord directly into the AC outlet. Do not use an isolation transformer for this check.
2. Connect a  $1.5\text{ k}\Omega$ ,  $10\text{ W}$  resistor, in parallel with a  $0.15\text{ }\mu\text{F}$  capacitor, between each exposed metallic part on the set and a good earth ground, as shown in Figure 1.
3. Use an AC voltmeter, with  $1\text{ k}\Omega/\text{V}$  or more sensitivity, to measure the potential across the resistor.
4. Check each exposed metallic part, and measure the voltage at each point.
5. Reverse the AC plug in the AC outlet and repeat each of the above measurements.
6. The potential at any point should not exceed  $0.75\text{ V RMS}$ . A leakage current tester (Simpson Model 229 or equivalent) may be used to make the hot checks, leakage current must not exceed  $1/2\text{ mA}$ . In case a measurement is outside of the limits specified, there is a possibility of a shock hazard, and the equipment should be repaired and rechecked before it is returned to the customer.

Hot-Check Circuit

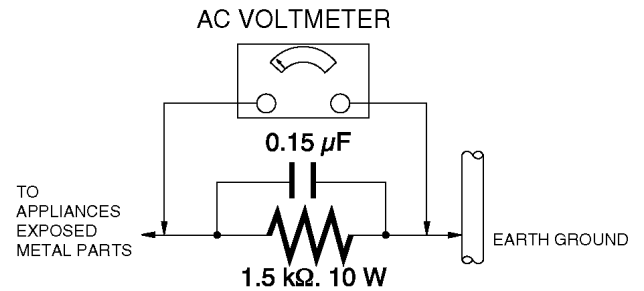

Figure. 1

## 1.4. How to Discharge the Capacitor on Flash Top PCB

### CAUTION:

1. Be sure to discharge the capacitor on FLASH TOP PCB.
2. Be careful of the high voltage circuit on FLASH TOP PCB when servicing.

### [Discharging Procedure]

1. Refer to the disassemble procedure and Remove the necessary parts/unit.
2. Put the insulation tube onto the lead part of Resistor (ERG5SJ102:1k $\Omega$  /5W).  
(an equivalent type of resistor may be used.)
3. Put the resistor between both terminals of capacitor on FLASH TOP PCB for approx. 5 seconds.
4. After discharging confirm that the capacitor voltage is lower than 10V using a voltmeter.

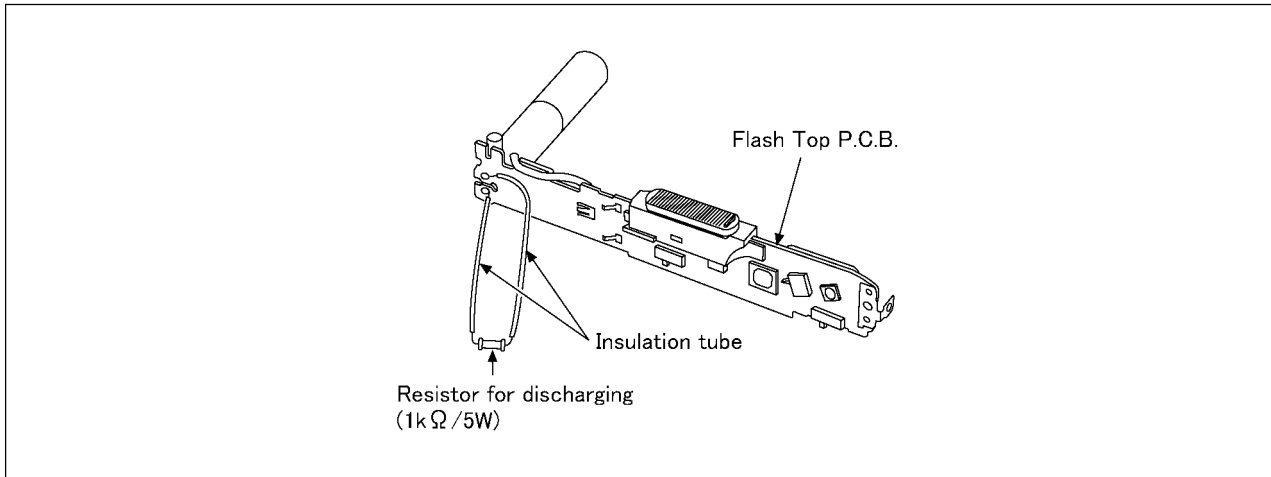

Fig. F1

## 2 Warning

### 2.1. Prevention of Electrostatic Discharge (ESD) to Electrostatically Sensitive (ES) Devices

Some semiconductor (solid state) devices can be damaged easily by static electricity. Such components commonly are called Electrostatically Sensitive (ES) Devices.

Examples of typical ES devices are CCD image sensor, IC (integrated circuits) and some field-effect transistors and semiconductor "chip" components.

The following techniques should be used to help reduce the incidence of component damage caused by electrostatic discharge (ESD).

1. Immediately before handling any semiconductor component or semiconductor-equipped assembly, drain off any ESD on your body by touching a known earth ground. Alternatively, obtain and wear a commercially available discharging ESD wrist strap, which should be removed for potential shock reasons prior to applying power to the unit under test.
2. After removing an electrical assembly equipped with ES devices, place the assembly on a conductive surface such as aluminum foil, to prevent electrostatic charge buildup or exposure of the assembly.
3. Use only a grounded-tip soldering iron to solder or unsolder ES devices.
4. Use only an antistatic solder removal device. Some solder removal devices not classified as "antistatic (ESD protected)" can generate electrical charge sufficient to damage ES devices.
5. Do not use freon-propelled chemicals. These can generate electrical charges sufficient to damage ES devices.
6. Do not remove a replacement ES device from its protective package until immediately before you are ready to install it. (Most replacement ES devices are packaged with leads electrically shorted together by conductive foam, aluminum foil or comparable conductive material).
7. Immediately before removing the protective material from the leads of a replacement ES device, touch the protective material to the chassis or circuit assembly into which the device will be installed.

**CAUTION :**

Be sure no power is applied to the chassis or circuit, and observe all other safety precautions.

8. Minimize bodily motions when handling unpackaged replacement ES devices. (Otherwise harmless motion such as the brushing together of your clothes fabric or the lifting of your foot from a carpeted floor can generate static electricity (ESD) sufficient to damage an ES device).

### 2.2. How to Recycle the Lithium Ion Battery (U.S. Only)

**ENGLISH**



A lithium ion battery that is recyclable powers the product you have purchased. Please call 1-800-8-BATTERY for information on how to recycle this battery.

**FRANÇAIS**



L'appareil que vous vous êtes procuré est alimenté par une batterie au lithium-ion recyclable. Pour des renseignements sur le recyclage de la batterie, veuillez composer le 1-800-8-BATTERY.

## 2.3. Caution for AC Cord (For EB/GC)

### 2.3.1. Information for Your Safety

#### IMPORTANT

Your attention is drawn to the fact that recording of pre-recorded tapes or discs or other published or broadcast material may infringe copyright laws.

#### WARNING

To reduce the risk of fire or shock hazard, do not expose this equipment to rain or moisture.

#### CAUTION

To reduce the risk of fire or shock hazard and annoying interference, use the recommended accessories only.

#### FOR YOUR SAFETY

##### DO NOT REMOVE THE OUTER COVER

To prevent electric shock, do not remove the cover. No user serviceable parts inside. Refer servicing to qualified service personnel.

### 2.3.2. Caution for AC Mains Lead

For your safety, please read the following text carefully.

This appliance is supplied with a moulded three-pin mains plug for your safety and convenience.

A 5-ampere fuse is fitted in this plug.

Should the fuse need to be replaced please ensure that the replacement fuse has a rating of 5 amperes and it is approved by ASTA or BSI to BS1362

Check for the ASRA mark or the BSI mark on the body of the fuse.



If the plug contains a removable fuse cover you must ensure that it is refitted when the fuse is replaced.

If you lose the fuse cover, the plug must not be used until a replacement cover is obtained.

A replacement fuse cover can be purchased from your local Panasonic Dealer.

If the fitted moulded plug is unsuitable for the socket outlet in your home then the fuse should be removed and the plug cut off and disposed of safely.

There is a danger of severe electrical shock if the cut off plug is inserted into any 13-ampere socket.

If a new plug is to be fitted please observe the wiring code as shown below.

If in any doubt, please consult a qualified electrician.

### 2.3.2.1. Important

The wires in this mains lead are coloured in accordance with the following code:

Blue	Neutral
Brown	Live

As the colours of the wires in the mains lead of this appliance may not correspond with the coloured markings identifying the terminals in your plug, proceed as follows:

The wire which is coloured BLUE must be connected to the terminal in the plug which is marked with the letter N or coloured BLACK.

The wire which is coloured BROWN must be connected to the terminal in the plug which is marked with the letter L or coloured RED.

Under no circumstances should either of these wires be connected to the earth terminal of the three pin plug, marked with the letter E or the Earth Symbol.



### 2.3.2.2. Before Use

Remove the Connector Cover as follows.

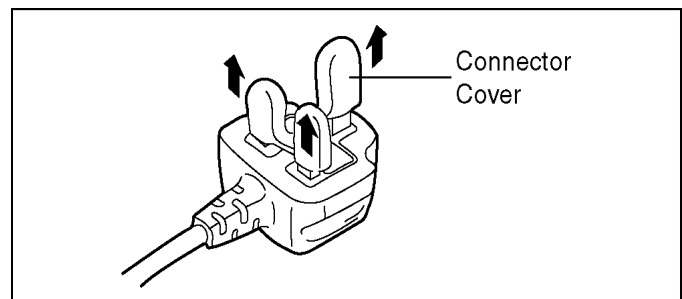

### 2.3.2.3. How to Replace the Fuse

1. Remove the Fuse Cover with a screwdriver.

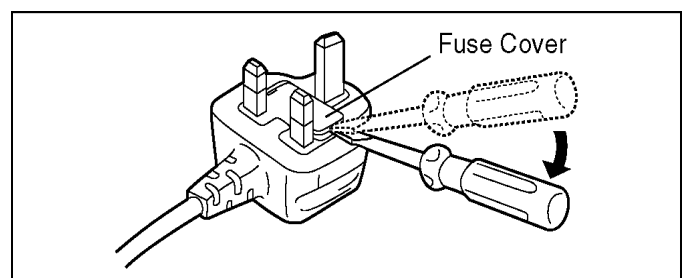

2. Replace the fuse and attach the Fuse cover.

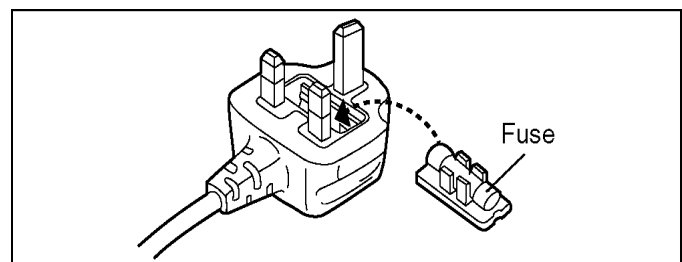

## 2.4. How to Replace the Lithium Battery

### 2.4.1. Replacement Procedure

1. Remove the MAIN PCB. (Refer to Disassembly Procedures.)
2. Unsolder the each soldering point of electric lead terminal for Lithium battery (Ref. No. "B9101" at foil side of MAIN PCB) and remove the Lithium battery together with electric lead terminal. Then replace it into new one.

**NOTE:**

The Type No. ML-421S/DN includes electric lead terminals.

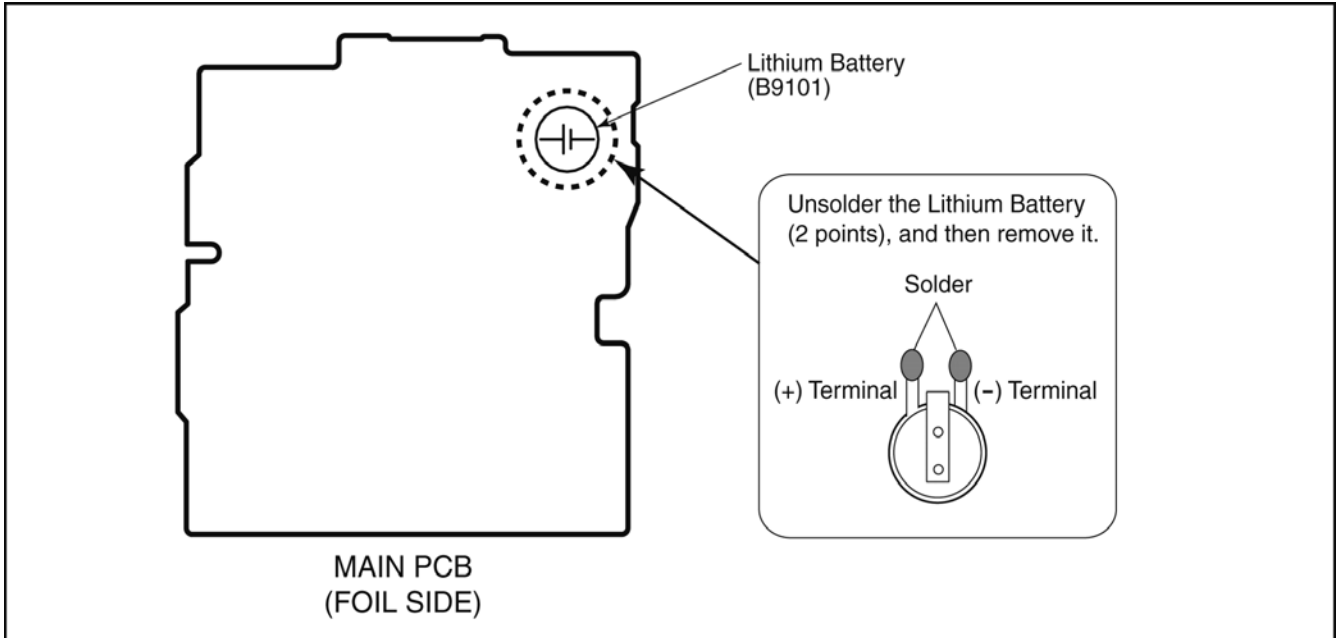

**NOTE:**

This Lithium battery is a critical component.

(Type No.: ML-421S/DN **Manufactured by Energy Company, Panasonic Corporation.**)

It must never be subjected to excessive heat or discharge.

It must therefore only be fitted in requirement designed specifically for its use.

Replacement batteries must be of same type and manufacture.

They must be fitted in the same manner and location as the original battery, with the correct polarity contacts observed.

Do not attempt to re-charge the old battery or re-use it for any other purpose.

It should be disposed of in waste products destined for burial rather than incineration.

**(For English)**

### CAUTION

Danger of explosion if battery is incorrectly replaced.

Replace only with the same or equivalent type recommended by the manufacturer.

Dispose of used batteries according to the manufacturer's instructions.

**(For German)**

### ACHTUNG

Explosionsgefahr bei falschem Anbringen der Batterie. Ersetzen Sie nur mit einem äquivalentem vom Hersteller empfohlenem Typ.

Behandeln Sie gebrauchte Batterien nach den Anweisungen des Herstellers.

**(For French)**

### MISE EN GARDE

Une batterie de remplacement inappropriée peut exploser. Ne remplacez qu'avec une batterie identique ou d'un type recommandé par le fabricant. L'élimination des batteries usées doit être faite conformément aux instructions du fabricant.

**NOTE:**

Above caution is applicable for a battery pack which is for DMC-FS15 series, as well.

## 3 Service Navigation

### 3.1. Introduction

This service manual contains technical information, which allow service personnel's to understand and service this model.

Please place orders using the parts list and not the drawing reference numbers.

If the circuit is changed or modified, the information will be followed by service manual to be controlled with original service manual.

### 3.2. General Description About Lead Free Solder (PbF)

The lead free solder has been used in the mounting process of all electrical components on the printed circuit boards used for this equipment in considering the globally environmental conservation.

The normal solder is the alloy of tin (Sn) and lead (Pb). On the other hand, the lead free solder is the alloy mainly consists of tin (Sn), silver (Ag) and Copper (Cu), and the melting point of the lead free solder is higher approx.30°C (86°F) more than that of the normal solder.

#### Distinction of PCB Lead Free Solder being used

The letter of "PbF" is printed either foil side or components side on the PCB using the lead free solder.(See right figure)
---

PbF
-----

#### Service caution for repair work using Lead Free Solder (PbF)

- The lead free solder has to be used when repairing the equipment for which the lead free solder is used.  
(Definition: The letter of "PbF" is printed on the PCB using the lead free solder.)
- To put lead free solder, it should be well molten and mixed with the original lead free solder.
- Remove the remaining lead free solder on the PCB cleanly for soldering of the new IC.
- Since the melting point of the lead free solder is higher than that of the normal lead solder, it takes the longer time to melt the lead free solder.
- Use the soldering iron (more than 70W) equipped with the temperature control after setting the temperature at 350±30°C (662±86°F).

#### Recommended Lead Free Solder (Service Parts Route.)

- The following 3 types of lead free solder are available through the service parts route.
  - RFKZ03D01K----- (0.3mm 100g Reel)
  - RFKZ06D01K----- (0.6mm 100g Reel)
  - RFKZ10D01K----- (1.0mm 100g Reel)

#### Note

\* Ingredient: tin (Sn) 96.5%, silver (Ag) 3.0%, Copper (Cu) 0.5%, Cobalt (Co) / Germanium (Ge) 0.1 to 0.3%

### 3.3. Important Notice 1:(Other than U.S.A. and Canadian Market)

1. The service manual does not contain the following information, because of the impossibility of servicing at component level without concerned equipment/facilities.
  - a. Schematic diagram, Block Diagram and PCB layout of MAIN PCB.
  - b. Parts list for individual parts for MAIN PCB.When a part replacement is required for repairing MAIN PCB, replace as an assembled parts. (MAIN PCB)
2. The following category is/are recycle module part. please send it/them to Central Repair Center.
  - MAIN PCB (VEP56075A): Excluding replacement of Lithium Battery



### 3.4. How to Define the Model Suffix (NTSC or PAL model)





There are six kinds of DMC-FS15, regardless of the colours.

- a) DMC-FS15P/PC
- b) DMC-FS15EB/EF/EG/EP/GN
- c) DMC-FS15EE
- d) DMC-FS15GT
- e) DMC-FS15GK
- f) DMC-FS15PR/PU/GC/GJ

What is the difference is that the "INITIAL SETTINGS" data which is stored in Flash ROM mounted on MAIN PCB.

#### 3.4.1. Defining methods:

To define the model suffix to be serviced, refer to the nameplate which is putted on the bottom side of the Unit.

<p><b>a) DMC-FS15P/PC</b> The nameplate for these models show the following Safety registration mark.</p> 
<p><b>b) DMC-FS15EB/EF/EG/EP/GN</b> The nameplate for these models show the following Safety registration mark.</p> 
<p><b>c) DMC-FS15EE</b> The nameplate for this model show the following Safety registration mark.</p> 
<p><b>d) DMC-FS15GT</b> The nameplate for this model show the following Safety registration mark.</p> 
<p><b>e) DMC-FS15GK</b> The nameplate for this model show the following Safety registration mark.</p> 
<p><b>f) DMC-FS15PR/PU/GC/GJ</b> The nameplate for these models do not show any above Safety registration mark.</p>

**NOTE:**

After replacing the MAIN PCB, be sure to achieve adjustment.

The adjustment instruction is available at "software download" on the "Support Information from NWBG/VDBG-AVC" web-site in "TSN system", together with Maintenance software.

### 3.4.2. INITIAL SETTINGS:

After replacing the MAIN PCB, be sure to perform the initial settings after achieving the adjustment by ordering the following procedure in accordance with model suffix of the unit.

#### 1. IMPORTANT NOTICE:

Before proceeding Initial settings, be sure to read the following CAUTIONS.

#### CAUTION 1:(INITIAL SETTINGS)

---AFTER REPLACING THE MAIN P.C.B. ---

\*.The model suffix can be chosen **JUST ONE TIME**.

(Model suffix : "P/EG/EP/PU/GC/GT/GK/EF/EB/EE/GN/PC/PR and GJ")

\*.Once one of the model suffix has been chosen, the model suffix lists will not be displayed, thus, it can not be changed.

[NOTE:Only for "EG, EP, EF, EB and EE" models]

\*.When one of the "EG, EP, EF, EB and EE" has been chosen, only "EG, EP, EF, EB and EE" are displayed from second times.

#### CAUTION 2:(Stored picture image data in the unit)

This unit employs "Built-in Memory" for picture image data recording.(Approx.50MB)

After proceeding "INITIAL SETTINGS", the picture image data stored in the unit is erased.

#### 2. PROCEDURES:

• Precautions: Read the above "CAUTION 1" and "CAUTION 2", carefully.

• Preparation:

1. Attach the Battery or AC Adaptor with a DC coupler to the unit.

2. Set the recording mode to the [NORMAL PICTURE] mode.

(Press the [MODE] button and select the [NORMAL PICTURE] by pressing the "[ UP ] and [DOWN] of Cursor buttons", then press the [MENU/SET] button.)

##### NOTE:

If the unit is other than [NORMAL PICTURE] mode, it does not display the initial settings menu.

• **Step 1. The temporary cancellation of "INITIAL SETTINGS":**

Set the [REC]/[PLAYBACK] selector switch to "[ REC ] (Camera mark)".

While keep pressing "[ UP ] of Cursor button" and [ iA ] button simultaneously, turn the Power on.

• **Step 2. The cancellation of "INITIAL SETTINGS":**

Set the [REC]/[PLAYBACK] selector switch to "[ PLAYBACK ]".

Press "[ UP ] of Cursor button" and [ iA ] button simultaneously, then turn the Power off.

• **Step 3. Turn the Power on:**

Set the [REC]/[PLAYBACK] selector switch to "[ REC ] (Camera mark)", and then turn the Power on.

• **Step 4. Display the INITIAL SETTING:**

##### NOTE:

If the unit is other than [NORMAL PICTURE] mode, it does not display the initial settings menu.

While keep pressing [ MENU/SET ] and "[ RIGHT ] of Cursor buttons" simultaneously, turn the Power off.

The "INITIAL SETTINGS" menu is displayed.

There are two kinds of "INITIAL SETTINGS" menu form as follows:

[CASE 1. After replacing MAIN P.C.B.]

When MAIN P.C.B. has just been replaced, all of the model suffix is displayed as follows. (Four pages in total)



[CASE 2. Other than "After replacing MAIN P.C.B."]



• **Step 5. Chose the model suffix in "INITIAL SETTINGS": (Refer to "CAUTION 1")**

[Caution: After replacing MAIN P.C.B.]

The model suffix can be chosen, **JUST ONE TIME**.

Once one of the model suffix have been chosen, the model suffix lists will not be displayed, thus, it can be changed.

Therefore, select the area carefully.

Select the area with pressing "[ UP ] / [ DOWN ] of Cursor buttons".

• **Step 6. Set the model suffix in "INITIAL SETTINGS":**

Press the "[ RIGHT ] of Cursor buttons".

The only set area is displayed, and then press the "[ RIGHT ] of Cursor buttons" after confirmation.

(The unit is powered off automatically.)

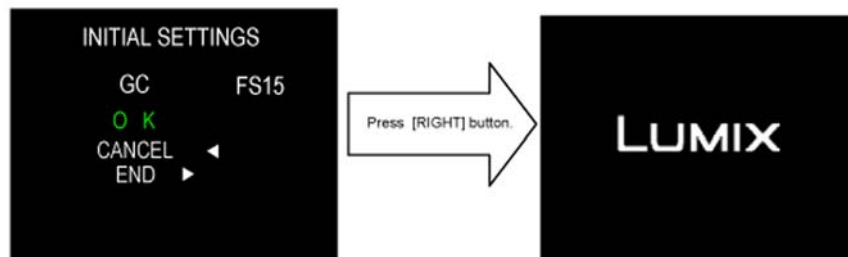

• **Step 7. CONFIRMATION:**

Confirm the display of "PLEASE SET THE CLOCK" in concerned language when the unit is turned on again.  
When the unit is connected to PC with USB cable, it is detected as removable media.

1) As for your reference, major default setting condition is as shown in the following table.

• **Default setting (After "INITIAL SETTINGS")**

	MODEL	VIDEO OUTPUT	LANGUAGE	DATE	REMARKS
a)	DMC-FS15P	NTSC	English	Month/Date/Year	
b)	DMC-FS15EG	PAL	English	Date/Month/Year	
c)	DMC-FS15EP	PAL	English	Date/Month/Year	
d)	DMC-FS15PU	NTSC	English	Month/Date/Year	
e)	DMC-FS15GC	PAL	English	Date/Month/Year	
f)	DMC-FS15GT	NTSC	Chinese (traditional)	Year/Month/Date	
g)	DMC-FS15GK	PAL	Chinese (simplified)	Year/Month/Date	
h)	DMC-FS15EF	PAL	French	Date/Month/Year	
i)	DMC-FS15EB	PAL	English	Date/Month/Year	
j)	DMC-FS15EE	PAL	Russian	Date/Month/Year	
k)	DMC-FS15GN	PAL	English	Date/Month/Year	
l)	DMC-FS15PC	NTSC	English	Month/Date/Year	
m)	DMC-FS15PR	PAL	English	Date/Month/Year	
n)	DMC-FS15GJ	PAL	Thai	Date/Month/Year	

# 4 Specifications

**Digital Camera:** Information for your safety

<b>Power Source:</b>	DC 5.1 V
<b>Power Consumption:</b>	1.35 W (When recording) 0.6 W (When playing back)

**Camera effective pixels:** 12,100,000 pixels  
**Image sensor:** 1/2.33" CCD, total pixel number 12,700,000 pixels, Primary color filter  
**Lens:** Optical 5× zoom, f=5.2 mm to 26 mm (35 mm film camera equivalent: 29 mm to 145 mm)/F3.3 to F5.9  
**Digital zoom:** Max. 4×  
**Extended optical zoom:** Max. 9.8×  
**Focus:** Normal/AF macro/Macro zoom/Face detection/AF Tracking/11-area-focusing/1-area-focusing  
**Focus range:** Normal: 50 cm (1.64 feet) (Wide)/1 m (3.28 feet) (Tele) to ∞  
Macro/Intelligent auto:  
5 cm (0.17 feet) (Wide)/1 m (3.28 feet) (Tele) to ∞  
Scene mode: There may be differences in the above settings.  
Electronic shutter+Mechanical shutter  
**Shutter system:**  
**Motion picture recording:** 848×480 pixels (30 frames/second, only when using a Card)/640×480 pixels (30 frames/second, only when using a Card)/320×240 pixels (30 frames/second)  
**Burst recording**  
**Burst speed:** 1.8 pictures/second (Normal), Approx. 1.7 pictures/second (Unlimited)  
**Number of recordable pictures:** Max. 5 pictures (Standard), Max. 3 pictures (Fine), Depends on the remaining capacity of the built-in memory or the card (Unlimited).  
(Performance in Burst recording is only with SD Memory Card/SDHC Memory Card. MultiMediaCard performance will be less.)  
**Hi-speed burst**  
**Burst speed:** Approx. 5 pictures/second  
(3M (4:3), 2.5M (3:2) or 2M (16:9) is selected as the picture size.)  
**Number of recordable pictures:** When using the built-in memory:  
Approx. 10 pictures (immediately after formatting)  
When using a Card: Max. 100 pictures (differs depending on the type of Card and the recording conditions)  
**ISO sensitivity:** AUTO/80/100/200/400/800/1600  
[HIGH SENS.] mode: 1600 to 6400  
**Shutter speed:** 8 seconds to 1/2000th of a second  
[STARRY SKY] mode: 15 seconds, 30 seconds, 60 seconds  
**White balance:** Auto white balance/Daylight/Cloudy/Shade/Incandescent lights/White set  
**Exposure (AE):** Program AE  
Exposure compensation (1/3 EV Step, -2 EV to +2 EV)  
**Metering mode:** Multiple  
**LCD monitor:** 2.7" TFT LCD  
(Approx. 230,000 dots) (field of view ratio about 100%)  
**Flash:** Flash range: [ISO AUTO]  
Approx. 30 cm (0.99 feet) to 5.3 m (17.4 feet) (Wide)  
AUTO, AUTO/Red-eye reduction, Forced flash ON (Forced ON/Red-eye reduction), Forced flash OFF (, Slow sync./Red-eye reduction)

**Microphone:** Monaural  
**Speaker:** Monaural  
**Recording media:** Built-in Memory (Approx. 50 MB)/SD Memory Card/SDHC Memory Card/MultiMediaCard (Still pictures only)

**Picture size**  
**Still picture:** When the aspect ratio setting is [4:3]  
4000×3000 pixels, 3264×2448 pixels, 2560×1920 pixels, 2048×1536 pixels, 1600×1200 pixels, 640×480 pixels  
When the aspect ratio setting is [3:2]  
4000×2672 pixels, 3264×2176 pixels, 2560×1712 pixels, 2048×1360 pixels  
When the aspect ratio setting is [16:9]  
4000×2248 pixels, 3264×1840 pixels, 2560×1440 pixels, 1920×1080 pixels  
**Motion pictures:** 848×480 pixels (Only when using a Card)/640×480 pixels (Only when using a Card)/320×240 pixels  
Fine/Standard

**Quality:**  
**Recording file format**  
**Still Picture:** JPEG (based on "Design rule for Camera File system", based on "Exif 2.21" standard)/DPOF corresponding  
**Motion pictures:** "QuickTime Motion JPEG" (motion pictures with audio)

**Interface**  
**Digital:** "USB 2.0" (High Speed)

**Analog video/ audio:** NTSC,  
Audio line output (monaural)

**Terminal**  
**[AV OUT/DIGITAL]:** Dedicated jack (8 pin)  
**Dimensions:** Approx. 97.0 mm (W)×54.4 mm (H)×21.7 mm (D)  
[Approx. 3 13/16" (W)×2 1/8"(H)×7/8" (D)]  
(excluding the projecting parts)

**Mass (weight):** Approx. 116 g/4.09 oz (excluding card and battery)  
Approx. 138 g/4.87 oz (with card and battery)

**Operating temperature:** 0 °C to 40 °C (32 °F to 104 °F)

**Operating humidity:** 10% to 80%

**Language select:** [ENGLISH]/[ESPAÑOL] (DMC-FS15P)  
[ENGLISH]/[DEUTSCH]/[FRANÇAIS]/[ESPAÑOL]/[ITALIANO]/  
[繁體中文]/[日本語] (DMC-FS15PC)

**Battery Charger**  
**(Panasonic DE-A59B):** Information for your safety

<b>Input:</b>	110 V to 240 V~50/60 Hz, 0.2 A
<b>Output:</b>	CHARGE 4.2 V===0.65 A

**Equipment mobility:** Movable

**Battery Pack**  
**(lithium-ion)**  
**(Panasonic DMW-BCF10PP):** Information for your safety

<b>Voltage/capacity</b> <b>(Minimum):</b>	3.6 V/940 mAh
--	---------------

**NOTE:(Only for "EB/EF/EG/EP/PR" models)**

- Data from the PC can not be written to the camera using the USB connection cable.
- Motion pictures can be recorded continuously for up to 15 minutes.  
The maximum continuous recording time (up to 15 minutes) is displayed on the screen.

# 5 Location of Controls and Components

## Names of the Components

- 1 Flash
- 2 Lens
- 3 Self-timer indicator  
AF assist lamp

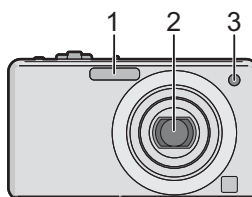

- 4 LCD monitor
- 5 Status indicator
- 6 [MENU/SET] button
- 7 [DISPLAY] button
- 8 [Q.MENU]/Delete button
- 9 [MODE] button
- 10 [REC]/[PLAYBACK] selector switch

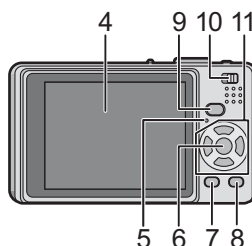

- 11 Cursor buttons
- Ⓐ: ▲/Exposure compensation/  
Auto bracket
- Ⓑ: ▼/Macro mode/AF tracking
- Ⓒ: ◀/Self-timer button
- Ⓓ: ▶/Flash setting button

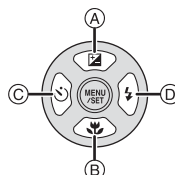

- 12 Camera ON/OFF switch
- 13 Zoom lever
- 14 Speaker
- 15 Microphone
- 16 Shutter button
- 17 Intelligent auto button

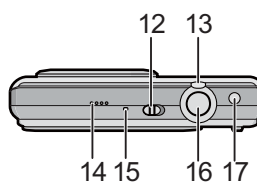

- 18 Hand strap eyelet
- Be sure to attach the hand strap when using the camera to ensure that you will not drop it.
- 19 Lens barrel
- 20 [AV OUT/DIGITAL] socket

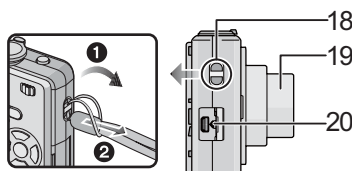

- 21 Tripod receptacle
- When you use a tripod, make sure the tripod is stable when the camera is attached to it.
- 22 Card/Battery door
- 23 Release lever
- 24 DC coupler cover
- When using an AC adaptor, ensure that the Panasonic DC coupler (DMW-DCC4; optional) and AC adaptor (DMW-AC5PP; optional) are used.

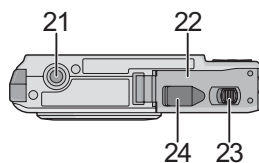

## Selecting the [REC] Mode

When the [REC] mode is selected, the camera can be set to the Intelligent auto mode in which the optimal settings are established in line with the subject to be recorded and the recording conditions, or to the Scene mode which enables you to take pictures that match the scene being recorded.

- 1 Turn the camera on.**
  - [MENU/SET] button
  - [REC]/[PLAYBACK] selector switch
  - [MODE] button
- 2 Slide the [REC]/[PLAYBACK] selector switch to .**
- 3 Press [MODE].**
- 4 Press  $\blacktriangle/\blacktriangledown$  to select the mode.**
- 5 Press [MENU/SET].**

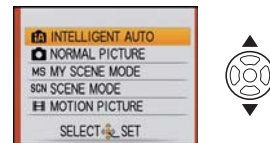
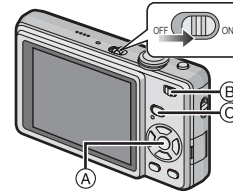

### List of [REC] modes

#### Intelligent auto mode

The subjects are recorded using settings automatically selected by the camera.

#### Normal picture mode

The subjects are recorded using your own settings.

#### **MS** My scene mode

Pictures are taken using previously registered recording scenes.

#### **SCN** Scene mode

This allows you to take pictures that match the scene being recorded.

#### Motion picture mode

This mode allows you to record motion pictures with audio.

### Note

- When the mode has been switched from [PLAYBACK] mode to [REC] mode, the previously set [REC] mode will be set.

## About the Battery

- This unit has a function that can distinguish useable batteries. Exclusive batteries are supported by this function. (Conventional batteries not supported by this function cannot be used.)

It has been found that counterfeit battery packs which look very similar to the genuine product are made available to purchase in some markets. Some of these battery packs are not adequately protected with internal protection to meet the requirements of appropriate safety standards. There is a possibility that these battery packs may lead to fire or explosion. Please be advised that we are not liable for any accident or failure occurring as a result of use of a counterfeit battery pack. To ensure that safe products are used we would recommend that a genuine Panasonic battery pack is used.

# 6 Service Mode

## 6.1. Error Code Memory Function

### 1. General description

This unit is equipped with history of error code memory function, and can be memorized 16 error codes in sequence from the latest. When the error is occurred more than 16, the oldest error is overwritten in sequence.

The error code is not memorized when the power supply is shut down forcibly (i.e., when the unit is powered on by the battery, the battery is pulled out) The error code is memorized to FLASH ROM when the unit has just before powered off.

### 2. How to display

The error code can be displayed by ordering the following procedure:

#### • Preparation:

1. Attach the Battery or AC Adaptor with a DC coupler to the unit.

#### NOTE:

\*Since this unit has built-in memory, it can be performed without inserting SD memory card.

\*It is not a matter of the setting condition of Recording mode (such as "normal picture/ iA / scene mode) to display the error code.

#### • Step 1. The temporary cancellation of "INITIAL SETTINGS":

Set the [REC]/[PLAYBACK] selector switch to "[ REC ] (Camera mark)".

While keep pressing "[ UP ] of Cursor button" and [ iA ] button simultaneously, turn the Power on.

#### • Step 2. Execute the error code display mode:

Press the "[ LEFT ] of Cursor button", [ MENU/SET ] button and [ iA ] button simultaneously.

The display is changed as shown below when the above buttons are pressed simultaneously.

Normal display → Error code display → Operation history display → Normal display → .....

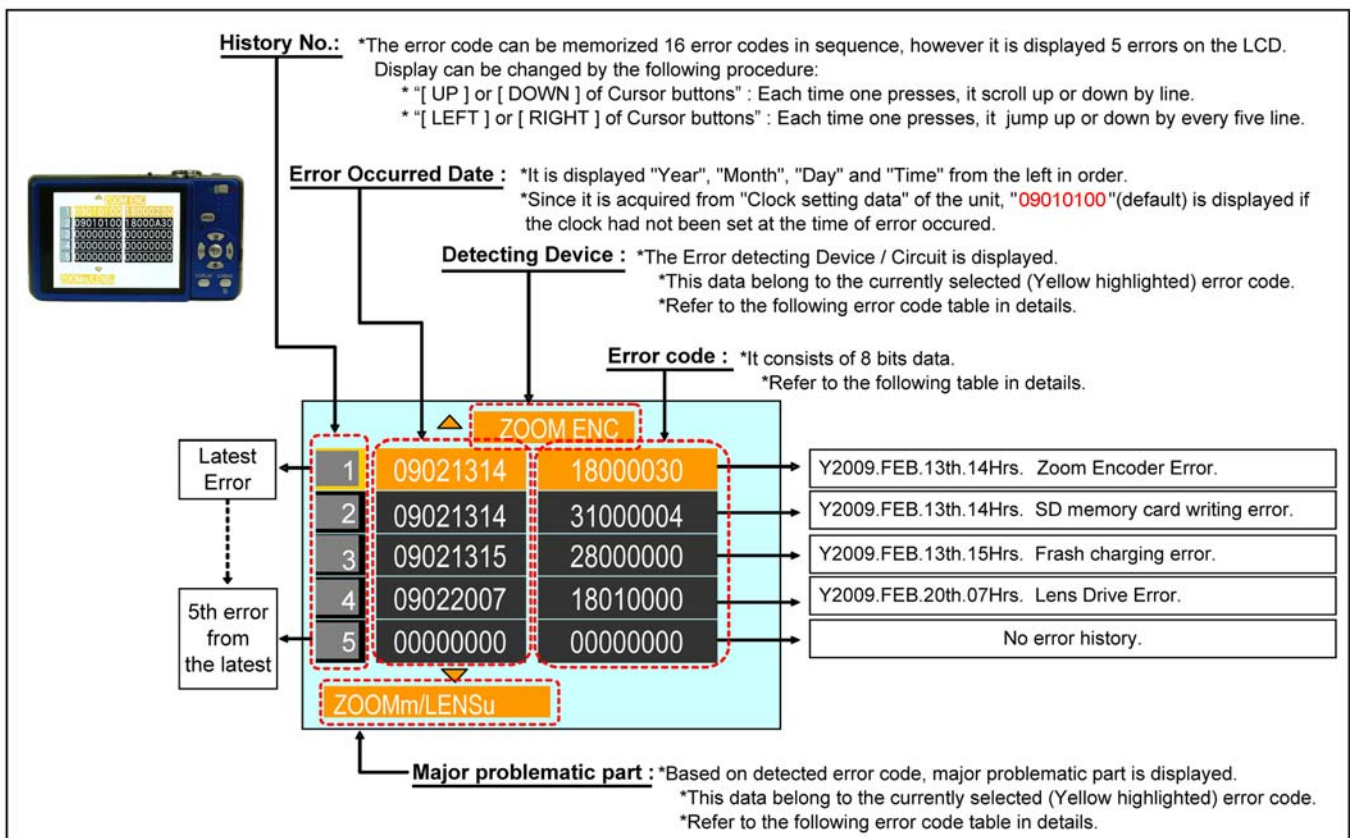

Example of Error Code Display



• 3. Error Code List

The error code consists of 8 bits data and it shows the following information.

Attribute	Main item	Sub item	Error code		Contents (Upper line)	Error Indication			
			High 4 bits	Low 4 bits	Problematic Part & Check point (Lower line)	Detecting device	Problematic Part/Circuit		
LENS	Lens drive	OIS	18*0	1000	PSD (X) error. Hall element (X axis) position detect error in OIS unit. OIS Unit	OIS X	LENSu NG		
				2000	PSD (Y) error. Hall element (Y axis) position detect error in OIS unit. OIS Unit	OIS Y			
			3000	GYRO (X) error. Gyro (IC7101: X axis) detect error on Main P.C.B.. IC7101 (Gyro element) or IC6001 (VENUS 4)	JYRO X	JYRO NG			
			4000	GYRO (Y) error. Gyro (IC7101: Y axis) detect error on Main P.C.B.. IC7101 (Gyro element) or IC6001 (VENUS 4)	JYRO Y				
			5000	MREF error (Reference voltage error). IC9101 (SYSTEM) or IC6001 (VENUS 4)	OIS REF	LENSsd/DSP NG			
			6000	Drive voltage (X) error. LENS Unit, LENS flex breaks, IC6001 (VENUS 4) AD value error, etc.	OISX REF	LENSu/LENS FPC			
			7000	Drive voltage (Y) error. LENS Unit, LENS flex breaks, IC6001 (VENUS 4) AD value error, etc.	OISY REF				
		Zoom (C.B.)	0710	Collapsible barrel Low detect error (Collapsible barrel encoder always detects Low.) Mechanical lock, FP9002-(3) signal line or IC6001 (VENUS 4)	ZOOM L	ZOOMm/LENSu			
				0720	Collapsible barrel High detect error (Collapsible barrel encoder always detects High.) Mechanical lock, FP9002-(3) signal line or IC6001 (VENUS 4)		ZOOM H		
			0730	Zoom motor sensor error. Mechanical lock, FP9002-(35), (38) signal line or IC6001 (VENUS 4)	ZOOM ENC				
			0740	Zoom motor sensor error. (During monitor mode.) Mechanical lock, FP9002-(35), (38) signal line or IC6001 (VENUS 4)					
			0750	Zoom motor sensor error. (During monitor mode with slow speed.) Mechanical lock, FP9002-(35), (38) signal line or IC6001 (VENUS 4)					
		Focus	0701	HP High detect error (Focus encoder always detects High, and not becomes Low) Mechanical lock, FP9002-(3) signal line or IC6001 (VENUS 4)	FOCUS L	LENS FPC/DSP			
			0702	HP Low detect error (Focus encoder always detects Low, and not becomes High) Mechanical lock, FP9002-(3) signal line or IC6001 (VENUS 4)	FOCUS H				
	Lens	18*1	0000	Power ON time out error. Lens drive system	LENS DRV	LENSu			
			18*2	0000			Power OFF time out error. Lens drive system		
	Adj. History	OIS	19*0	2000	OIS adj. Yaw direction amplitude error (small)	OIS ADJ	OIS ADJ		
				3000	OIS adj. Pitch direction amplitude error (small)				
				4000	OIS adj. Yaw direction amplitude error (large)				
				5000	OIS adj. Pitch direction amplitude error (large)				
				6000	OIS adj. MREF error				
				7000	OIS adj. time out error				
				8000	OIS adj. Yaw direction off set error				
				9000	OIS adj. Pitch direction off set error				
				A000	OIS adj. Yaw direction gain error				
				B000	OIS adj. Pitch direction gain error				
				C000	OIS adj. Yaw direction position sensor error				
				D000	OIS adj. Pitch direction position sensor error				
E000				OIS adj. other error					
HARD				VENUS A/D	Flash			28*0	0000
	FLASH ROM (EEPROM Area)	FLASH ROM (EEPROM Area)	2B*0	0001	EEPROM read error	FROM RE	FROM		
				0003	IC6002 (FLASH ROM)	FROM WR	FROM		
				0004	EEPROM write error IC6002 (FLASH ROM)				
				0005	Firmware version up error Replace the firmware file in the SD memory card.	(No indication)	(No indication)		
				0008	SDRAM error	(No indication)	(No indication)		
	0009	SDRAM Mounting defective							
	SYSTEM	RTC	2C*0	0001	SYSTEM IC initialize failure error Communication between IC6001 (VENUS 4) and IC9101 (SYSTEM)	SYS INIT	MAIN PCB		
	SOFT	CPU	Reset	30*0	0001	NMI reset Non Mask-able Interrupt (30000001-30000007 are caused by factors)	NMI RST	MAIN PCB	
		Card	Card	31*0	0001	Card logic error SD memory card data line or IC6001 (VENUS 4)	SD CARD	SD CARD/DSP	
0002					Card physical error SD memory card data line or IC6001 (VENUS 4)				
0004					Write error SD memory card data line or IC6001 (VENUS 4)	SD WRITE			
39*0					0005	Format error	INMEMORY		FROM
CPU ASIC					Stop	38*0	0001		Camera task finish process time out. Communication between Lens system and IC6001 (VENUS 4)
		0002	Camera task invalid code error. IC6001 (VENUS 4)	DSP			DSP		
		0100	File time out error in recording motion image IC6001 (VENUS 4)						
		0200	File data cue send error in recording motion image IC6001 (VENUS 4)						
Memory area		3A*0	0008	USB work area partitioning failure USB dynamic memory securing failure when connecting	(No indication)	(No indication)			
				Operation Zoom	Power on Zoom	3B*0	0000	FLASHROM processing early period of camera during movement.	INIT
Zoom		Zoom	3C*0	0000	Imperfect zoom lens processing Zoom lens	ZOOM	ZOOMm/LENSu		
				35*0	0000	Software error (0-7bit : command, 8-15bit : status)	DSP	DSP	
	35*1			FFFF	Though record preprocessing is necessary, it is not called.				
	35*2			0000	Though record preprocessing is necessary, it is not completed.	(No indication)			(No indication)

## Important notice about "Error Code List"

### 1) About "\*" indication:

The third digit from the left is different as follows.

- In case of 0 (example: 18001000)

When the third digit from the left shows "0", this error occurred under the condition of INITIAL SETTINGS has been completed.

It means that this error is occurred basically at user side.

- In case of 8 (example: 18801000)

When the third digit from the left shows "8", this error occurred under the condition of INITIAL SETTINGS has been released.

(Example; Factory assembling-line before unit shipment, Service mode etc.)

It means that this error is occurred at service side.

### 2) About "?" indication: ("18\*0 0?01" to "18\*0 0?50"):

The third digit from the right shows one of the hexadecimal ("0" to "F") character.

### • 4. How to exit from Error Code display mode:

Simply, turn the power off. (Since Error code display mode is executed under the condition of temporary cancellation of "INITIAL SETTINGS", it wake up with normal condition when turn off the power.)



#### NOTE:

The error code can not be initialized.

# 7 Service Fixture & Tools

## 7.1. Service Fixture and Tools

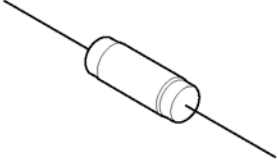
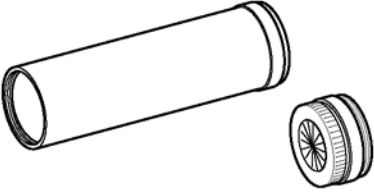
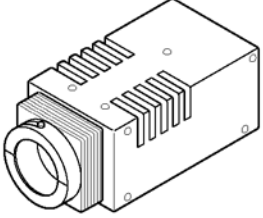
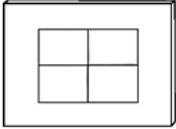
The following Service Fixture and tools are used for checking and servicing this unit.

<b>Resistor for Discharging</b> <b>ERG5SJ102</b>	<b>Infinity Lens (with Focus Chart)</b> <b>VFK1164TCM02</b>	<b>LIGHT BOX</b> <b>VFK1164TDVLB</b>
 <p>An equivalent type of Resistor may be used.</p>	 <p>* RFKZ0422 can be used.</p>	 <p>※ with DC Cable</p>
<b>TR Chart</b> <b>RFKZ0443</b>	<b>Lens Cleaning Kit (BK)</b> <b>VFK1900BK</b>	<b>Grease (for lens)</b> <b>RFKZ0472</b>
	 <p>* Only supplied as 10 set/box.</p>	

## 7.2. When Replacing the Main PCB

After replacing the MAIN PCB, be sure to achieve adjustment.

The adjustment instruction is available at “software download” on the “Support Information from NWBG/VDBG-AVC” web-site in “TSN system”, together with Maintenance software.

## 7.3. Service Position

This Service Position is used for checking and replacing parts. Use the following Extension cables for servicing.

Table S1 Extension Cable List

No.	Parts No.	Connection	Form
1	RFKZ0416	FP9001 (MAIN) - CCD UNIT	41PIN 0.3 FFC
2	RFKZ0477	FP9002 (MAIN) - LENS UNIT	45PIN 0.3 FFC
3	RFKZ0418	PP9001 (MAIN) - PS8001 (FLASH TOP)	30PIN B to B

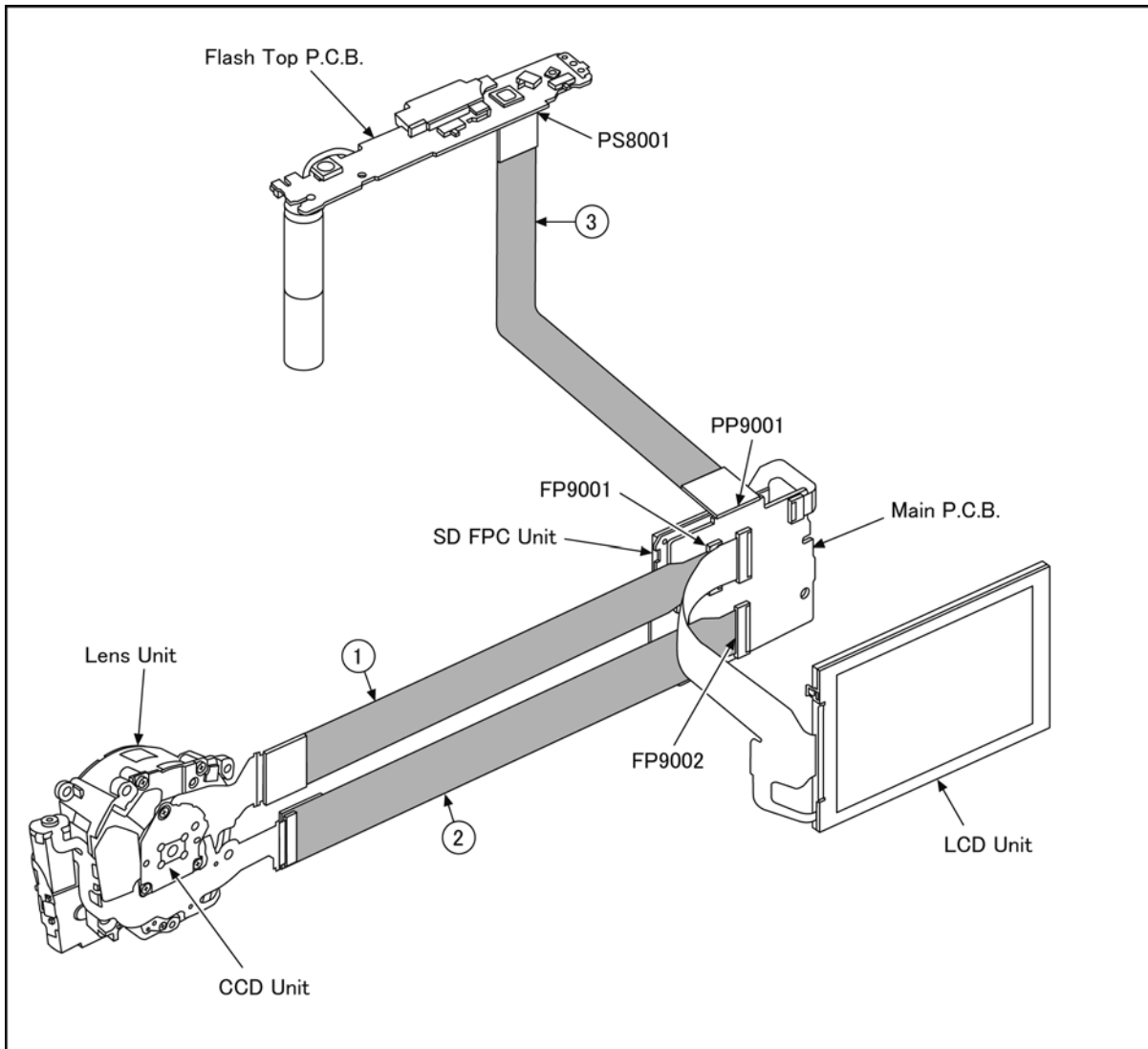

### CAUTION-1. (When servicing FLASH TOP PCB)

1. Be sure to discharge the capacitor on FLASH TOP PCB.

Refer to “HOW TO DISCHARGE THE CAPACITOR ON FLASH TOP PCB”.

The capacitor voltage is not lowered soon even if the AC Cord is unplugged or the battery is removed.

2. Be careful of the high voltage circuit on FLASH TOP PCB.

3. DO NOT allow other parts to touch the high voltage circuit on FLASH TOP PCB.

# 8 Disassembly and Assembly Instructions

## 8.1. Disassembly Flow Chart

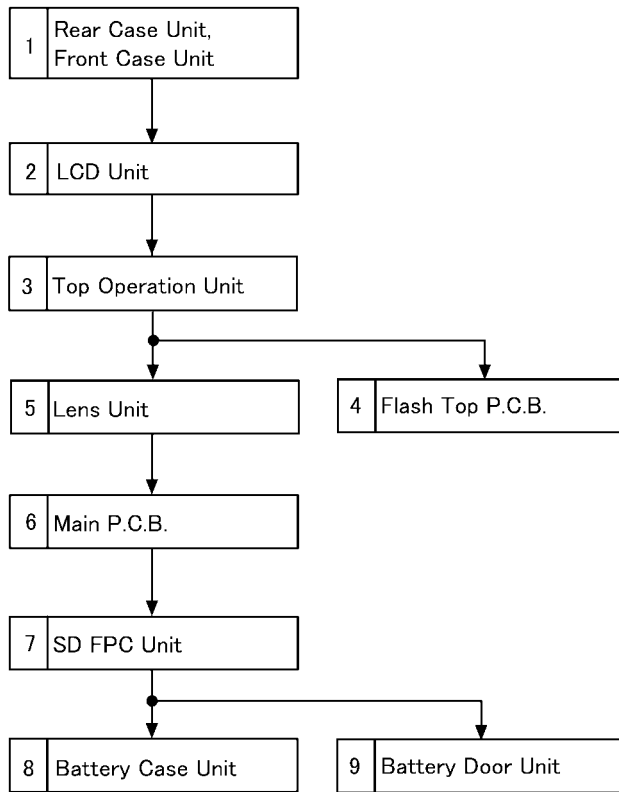

## 8.2. PCB Location

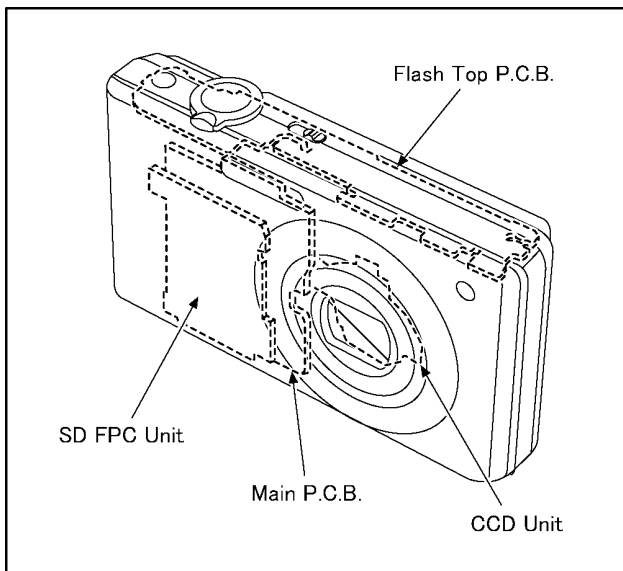

## 8.3. Disassembly Procedure

### 8.3.1. Removal of the Rear Case Unit and Front Case Unit

No.	Item	Fig	Removal
1	Rear Case Unit Front Case Unit	(Fig. D1)	Card
			Battery
			1 Screw (A)
			3 Screws (B)
			2 Screws (C)
			Side Ornament (L)
			Jack Door
		(Fig. D2)	Side Ornament (R)
			4 Locking tabs
			Rear Case Unit
			Front Case Unit
2	LCD Unit	(Fig. D3)	1 Locking tab (A)
			2 Locking tabs (B)
			3 Screws (D)
			Frame Plate
			Tripod Fixing Plate
			FP9103(Flex)
			LCD Unit
3	Top Operation Unit	(Fig. D4)	PS8001(Connector)
			Top Operation Unit
4	Flash Top P.C.B.	(Fig. D5)	5 Locking tabs
			AF Panel Light
			2 Screws (E)
		(Fig. D6)	Top Ornament Unit
			Speaker Unit
			Mic Damper
			Power Knob Base
			Power Knob
			Flash Top P.C.B.
(Fig. D7)	NOTE: (When installing)		
5	Lens Unit	(Fig. D8)	FP9001(Flex)
			FP9002(Flex)
			Lens Unit
6	Main P.C.B.	(Fig. D9)	1 Screw (F)
			FP9005(Flex)
			1 Locking tab
			Main P.C.B.
7	SD FPC Unit	(Fig. D10)	1 Screw (G)
			SD FPC Unit
8	Battery Case Unit	(Fig. D11)	Earth Plate
			1 Locking tab
		(Fig. D12)	Battery Out Spring
9	Battery Door Unit	(Fig. D13)	Battery Case Unit
			Battery Door Shaft
			Battery Door Spring
			Battery Door Unit

#### NOTE:

When servicing and reassembling, remove the card and battery from the unit.

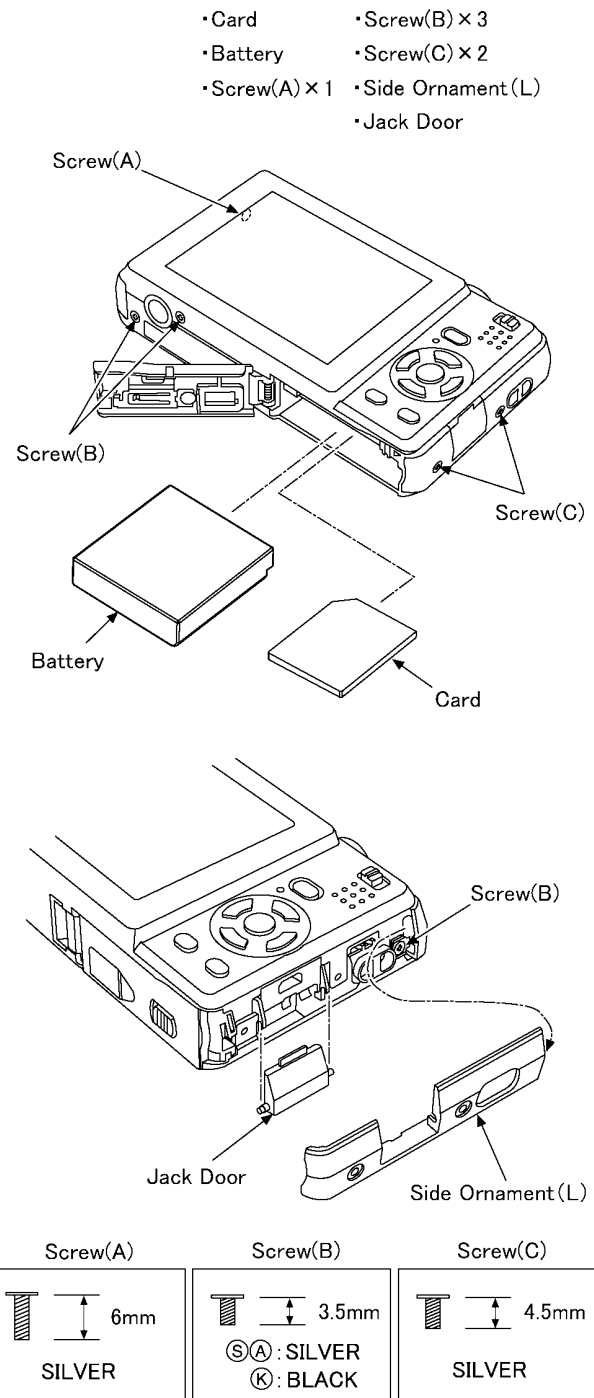

(Fig. D1)

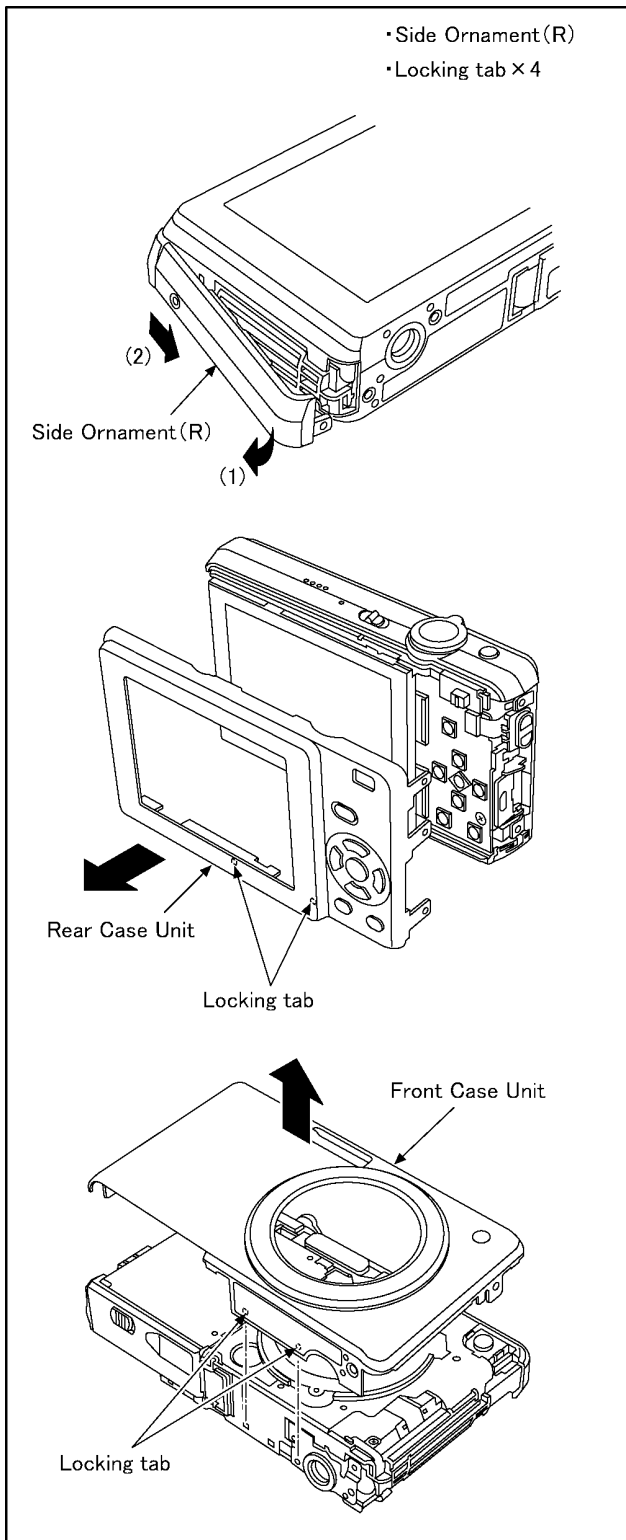

(Fig. D2)

### 8.3.2. Removal of the LCD Unit

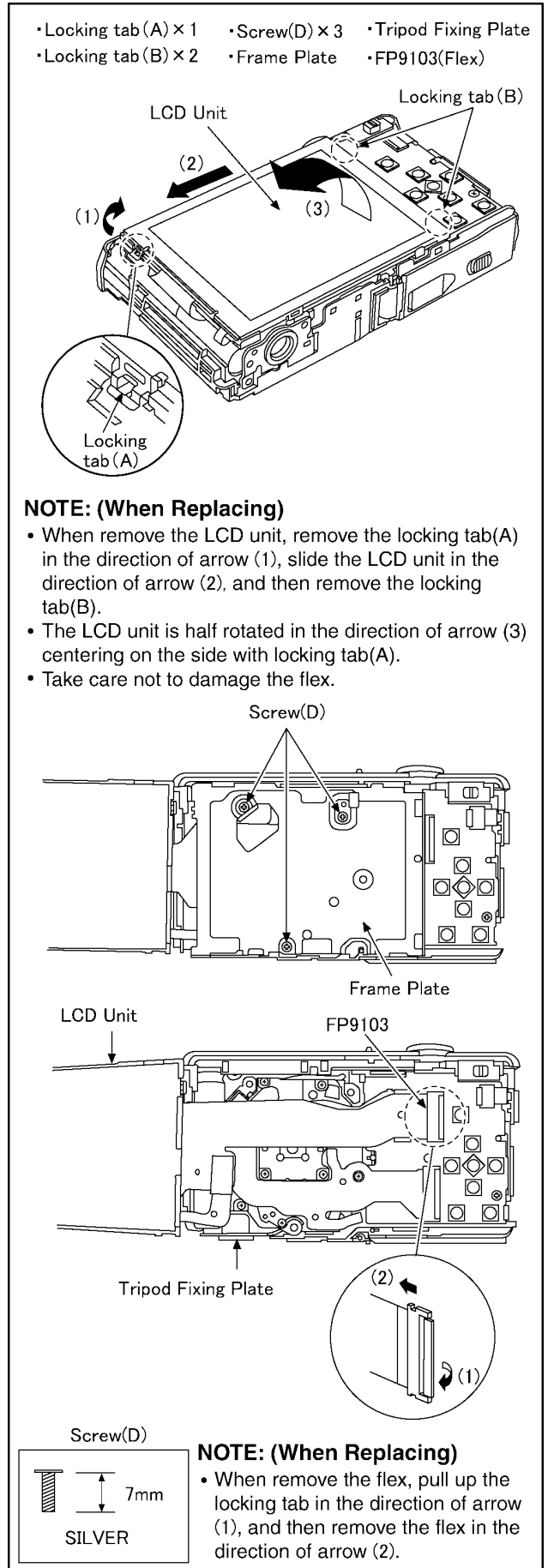

(Fig. D3)

### 8.3.3. Removal of the Top Operation Unit

**IMPORTANT NOTICE:**

Take care not apply any bending load to the charging capacitor. It brings about the possibility of PCB and/or component damage on the Flash Top P.C.B.

•PS8001(Connector)

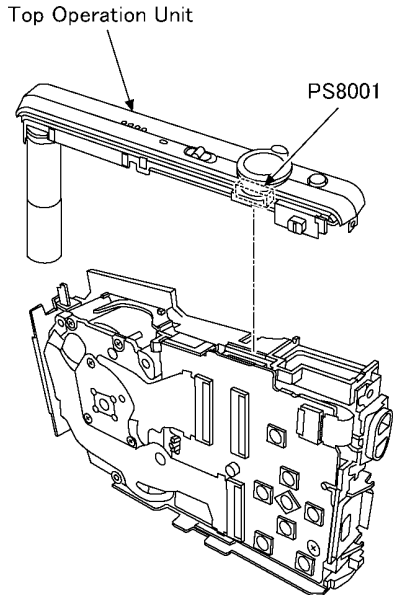

(Fig. D4)

### 8.3.4. Removal of the Flash Top P.C.B.

•Locking tab × 5  
•AF Panel Light  
•Screw(E) × 2

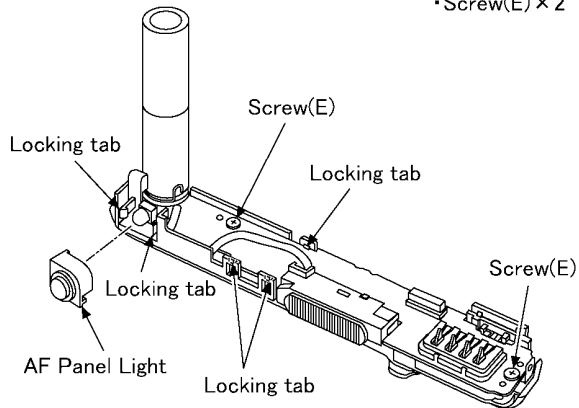

(Fig. D5)

**IMPORTANT NOTICE:**

Take care not apply any bending load to the charging capacitor. It brings about the possibility of PCB and/or component damage on the Flash Top P.C.B.

•Top Ornament Unit      •POWER Knob Base  
•Speaker Unit            •POWER Knob  
•Mic Damper

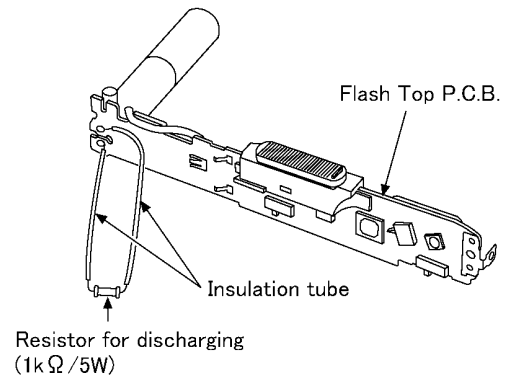
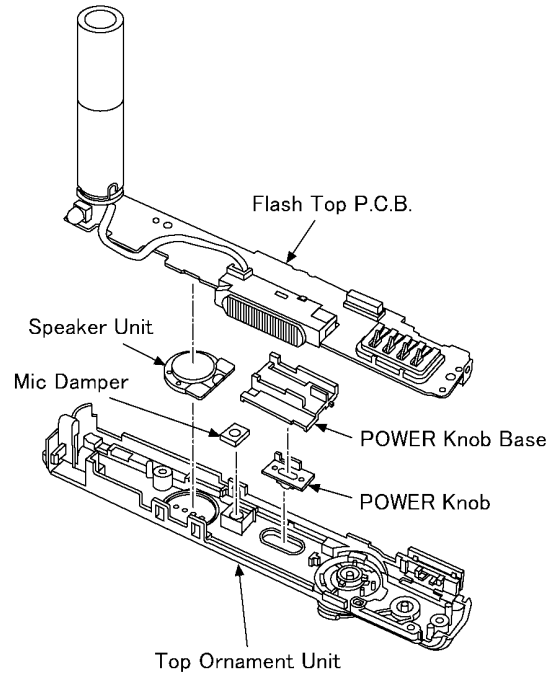

**CAUTION**

**Be sure to discharge the capacitor on Flash Top P.C.B. before disassembling.**

1. Remove the Flash Top P.C.B..
2. Put the insulation tube on the lead part of resistor (ERG5SJ102: 1kΩ/5W).
3. Put the resistor between both terminals of capacitor unit for approx. 5 seconds.

(Fig. D6)



**NOTE: (When Installing)**

- Align the convex of power switch and power knob.
- Align the convex of REC/PLAYBACK selector switch and REC/PLAYBACK selector knob.

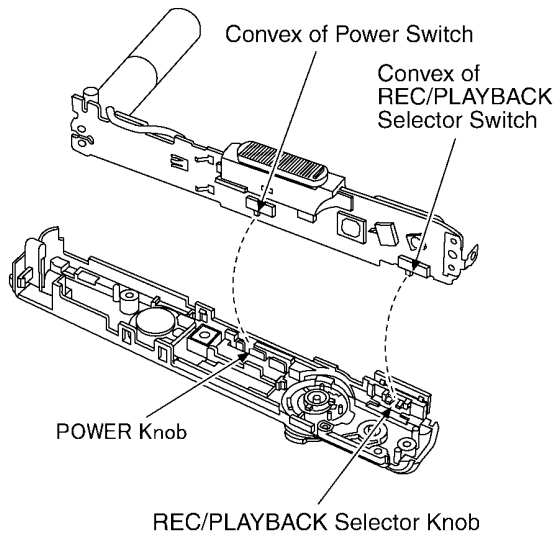

(Fig. D7)

**8.3.5. Removal of the Lens Unit**

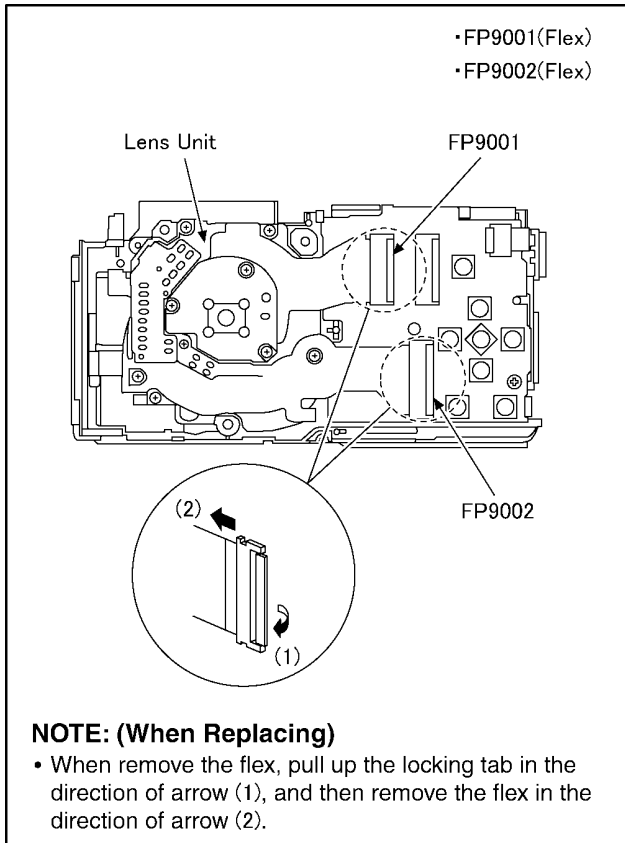

(Fig. D8)

**8.3.6. Removal of the Main P.C.B.**

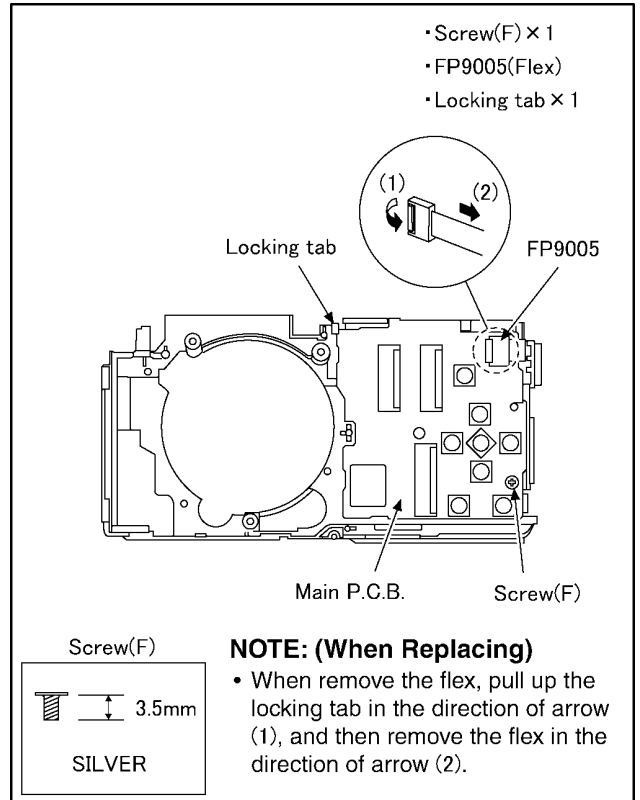

(Fig. D9)

**8.3.7. Removal of the SD FPC Unit**

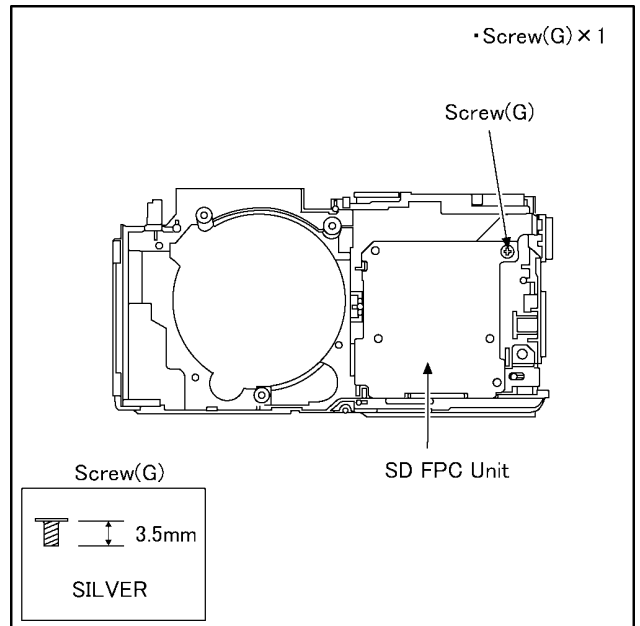

(Fig. D10)

### 8.3.8. Removal of the Battery Case Unit

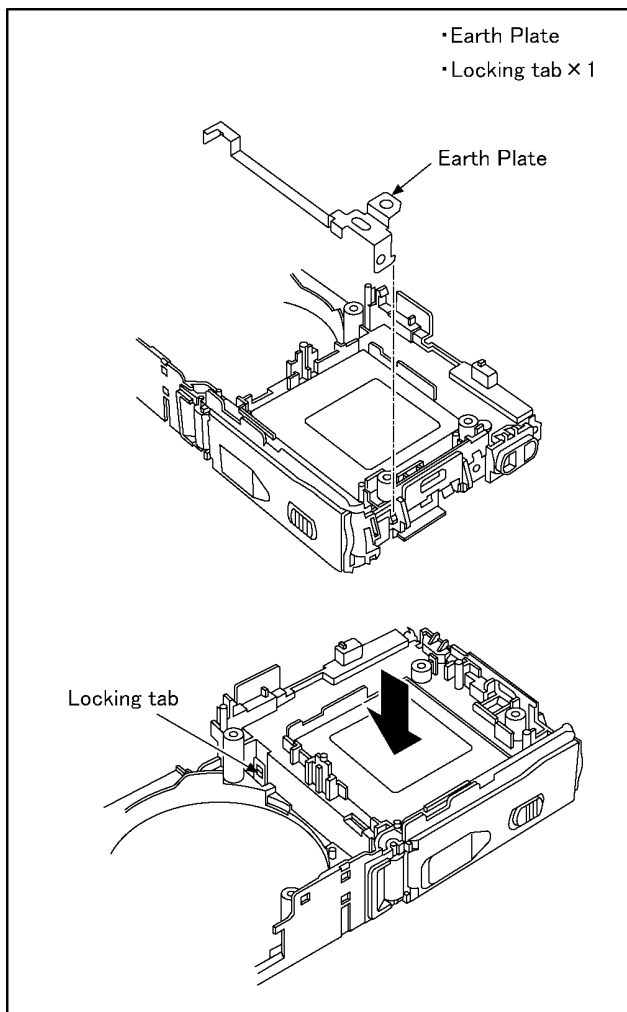

(Fig. D11)

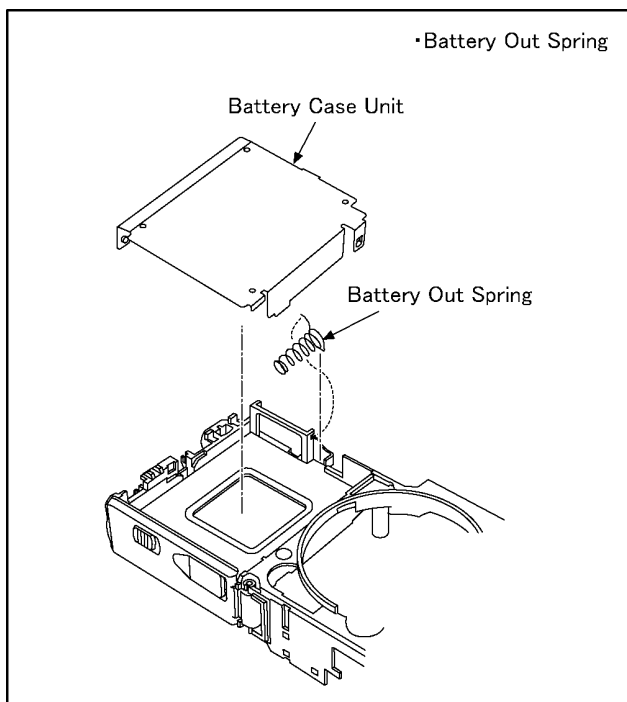

(Fig. D12)

### 8.3.9. Removal of the Battery Door Unit

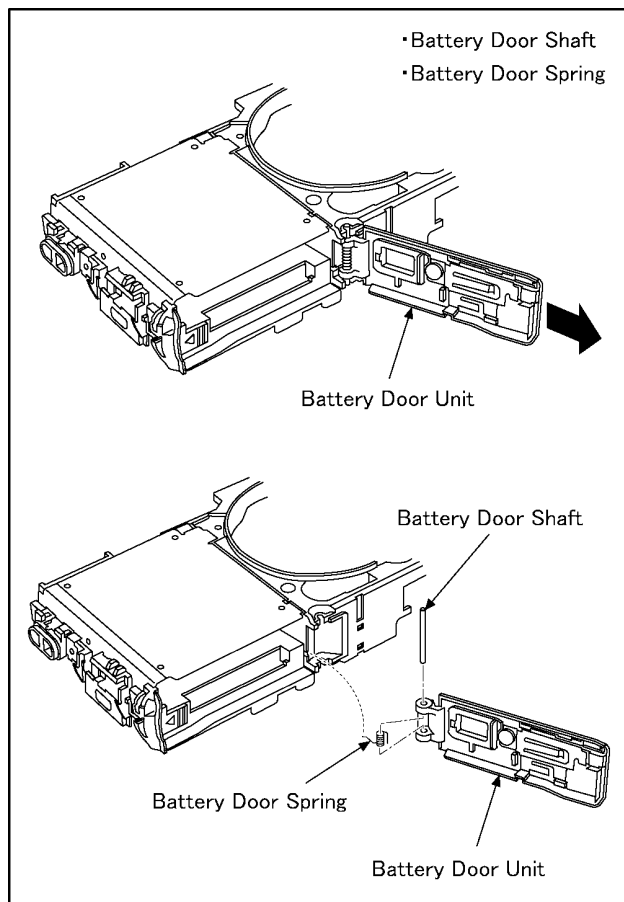

(Fig. D13)

#### NOTE: (When Assembling)

Be sure to confirm the following points when assembling.

- The Screw is tightened enough.
- Assembling conditions are fine. (No distortion, no illegal-space.)
- No dust and/or dirt on every Lens surfaces.
- LCD image is fine. (No dust and dirt on it, and no gradient images.)

## 8.4. Disassembly Procedure for the Lens

### NOTE: When Disassembling and Assembling for the Lens

- To minimize the possibility of the CCD being dirt, perform disassemble and/or assemble under the condition of the CCD is being mounted.  
Disassembling procedures for the CCD unit, refer to item 8.6.
- Take care that the dust and dirt are not entered into the lens.  
In case of the dust is putted on the lens, blow off them by airbrush.
- Do not touch the surface of lens.
- Use lens cleaning KIT (BK)(VFK1900BK).
- Apply the grease (RFKZ0472) to the point where is shown to "Grease apply" in the figure.  
When the grease is applied, use a toothpick and apply thinly.
- When repair the fixed frame, drive frame and direct frame, must be unit exchange.

### 8.4.1. Removal of the Zoom Motor Unit and Lens FPC P.C.B. Unit

- Remove the 1 solder (A).
- Remove the 1 solder (B).
- Unscrew the 2 screws (A).
- Unscrew the 1 screw (B).
- Remove the 2 locks.
- Remove the zoom motor unit to the indicated by arrow (1).
- Remove the lens FPC P.C.B. unit to the indicated by arrow (2).

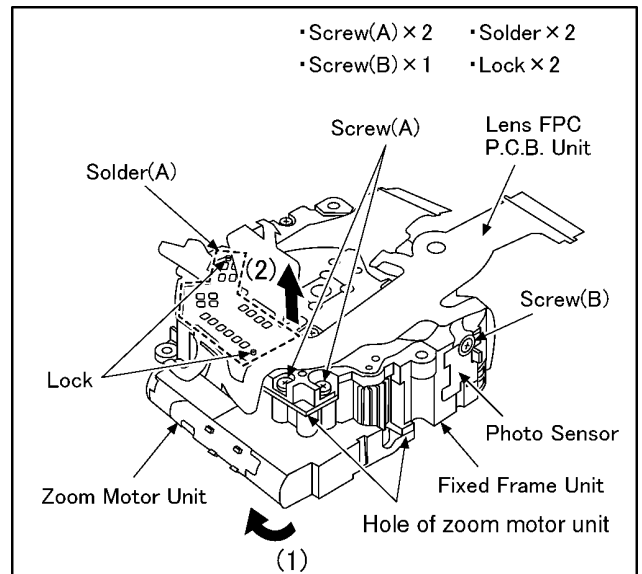

### NOTE: (When Assembling)

- Align the convex of fixed frame unit and hole of zoom motor unit, and then install them.

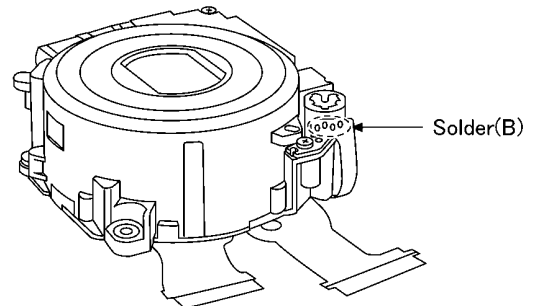

### NOTE: (When Assembling)

- Take care not to damage the flex.

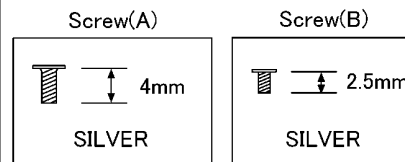

### 8.4.2. Removal of the Master Flange Unit

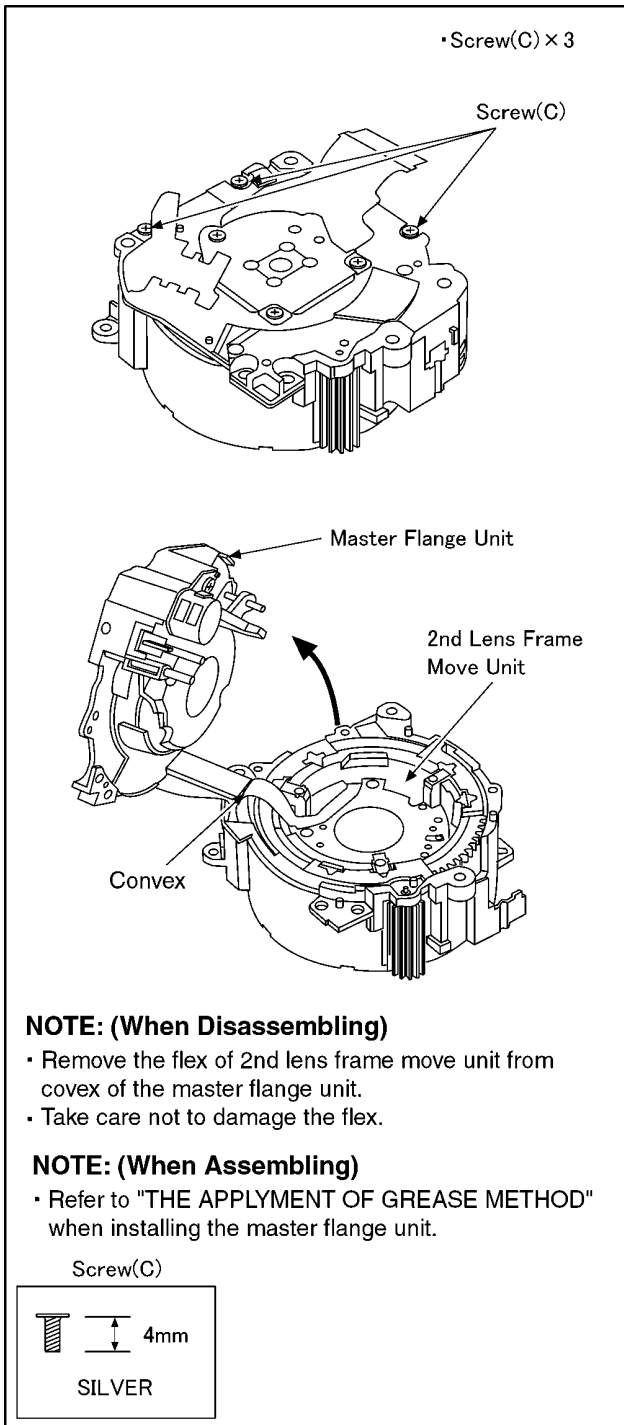

### 8.4.3. Removal of the 1st Lens Frame/2nd Lens Frame Move Unit

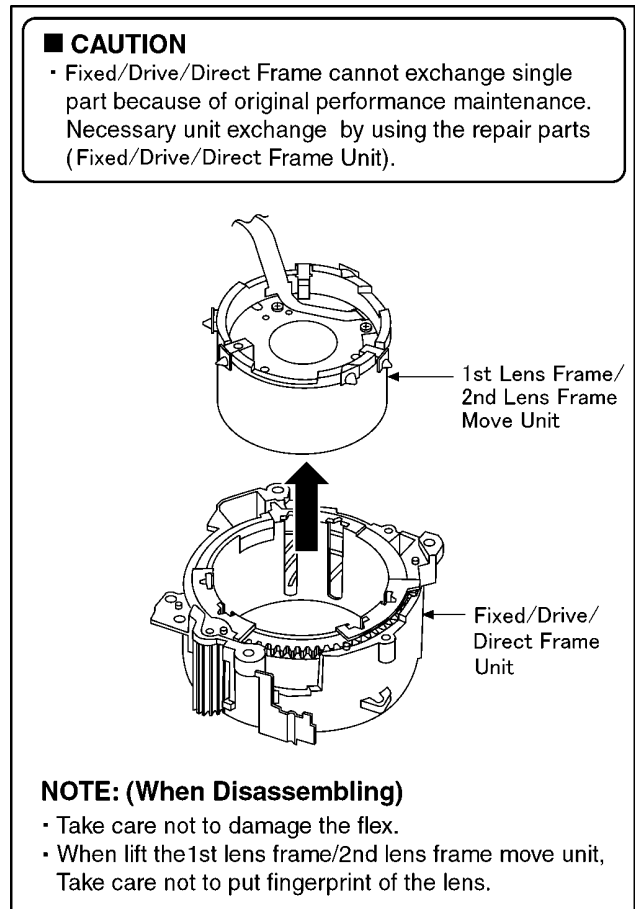

### 8.4.4. Removal of the 2nd Lens Frame Move Unit

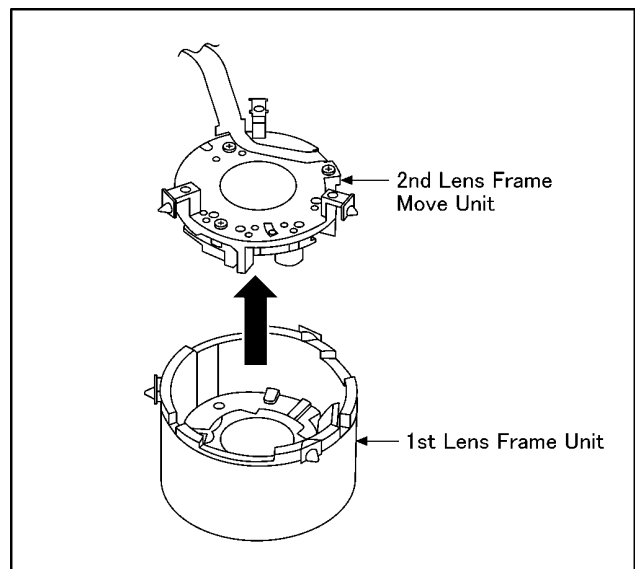

## 8.5. Assembly Procedure for the Lens

### 8.5.1. Phase alignment of the Direct Frame and Drive Frame Unit

- Insert the shading sheet to drive frame.  
(When insert the shading sheet, so that the luster side facing to subject side)
- Align the  $\Delta$  mark of direct frame and groove in the interior of  $\Delta$  mark of drive frame, and then install the direct frame to drive frame.

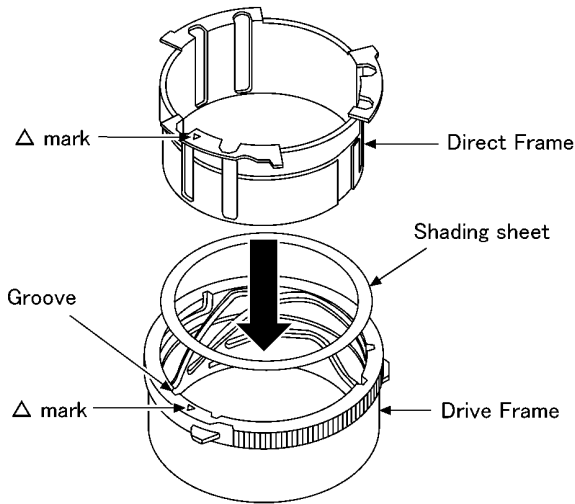

- Move the external U cut of direct frame to gear edge, and then align the phase of the groove (6 points).

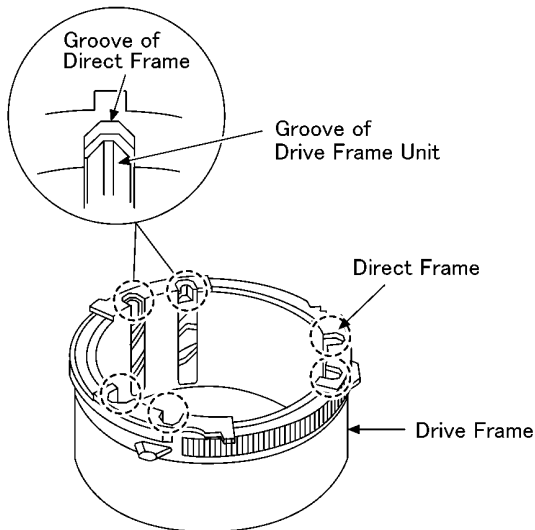

### 8.5.2. Phase alignment of the Drive/Direct Unit and Fixed Frame Unit

- Align the  $\Delta$  mark, and then install the drive/direct frame unit to fixed frame unit.

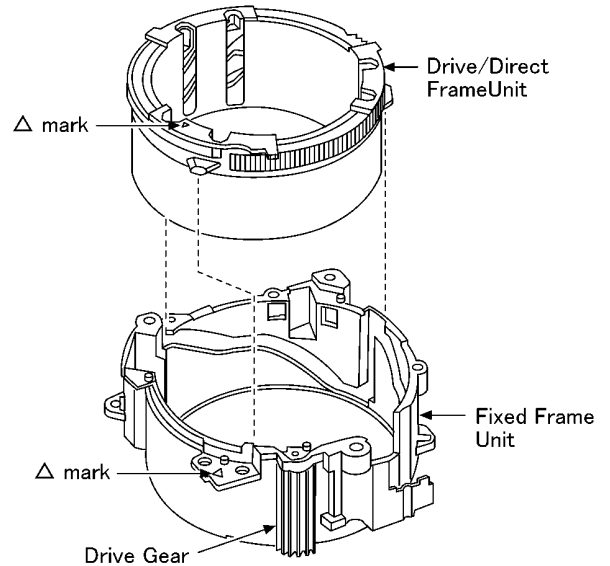

#### NOTE: (When Assembling)

- With aligning the phase of the drive/direct frame unit, confirm the gear of drive unit is engaged with the fixed frame unit firmly.

**8.5.3. Assembly for the 1st Lens Frame Unit and Fixed/Drive/Direct Frame Unit**

- Inserts the 1st lens frame unit to the drive/direct/fixed frame unit so that the barrier drive lever may become the position of the figure below.

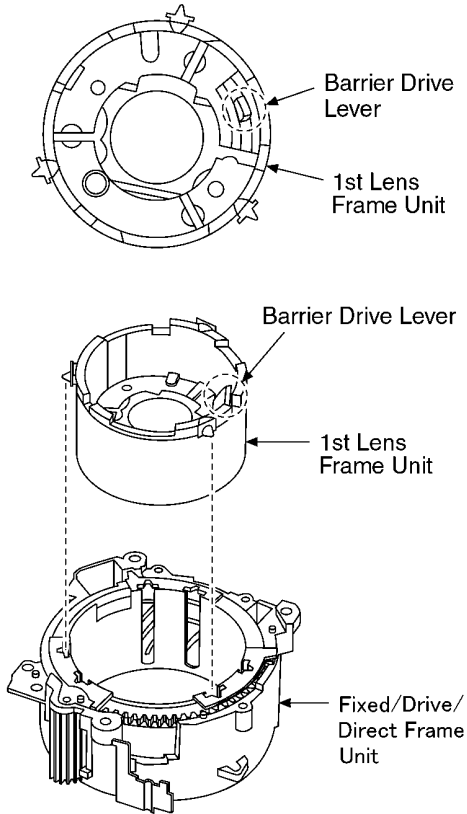

**NOTE: (When Assembling)**

Take care not to put fingerprint of the lens.

**FRONT VIEW**

- Install the 1st lens frame unit so that the "LEICA" character may become the position of the figure below.

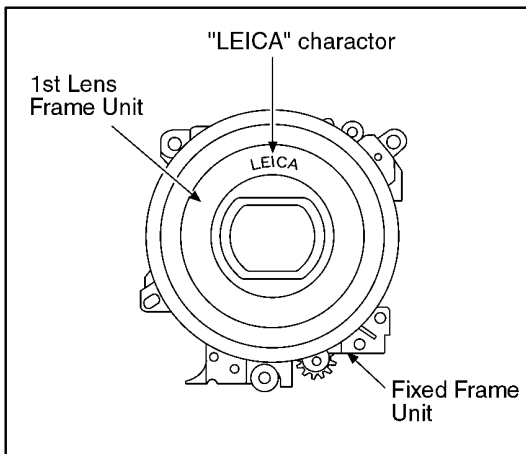

**8.5.4. Assembly for the 2nd Lens Frame Move Unit and Fixed/Drive/Direct Frame/1st Lens Frame Unit**

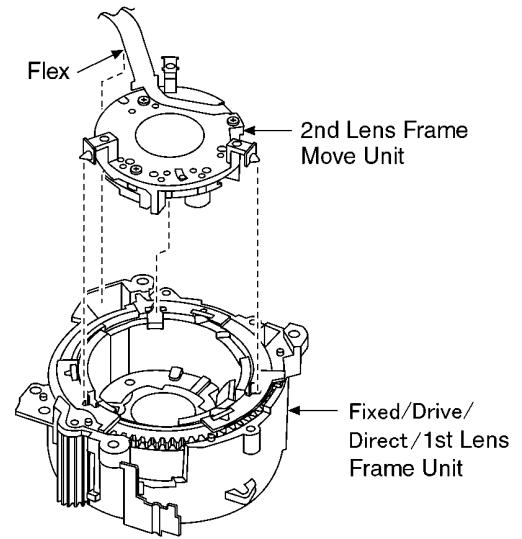

**NOTE: (When Assembling)**

Take care not to put fingerprint of the lens.

### 8.5.5. Assembly for the Master Flange Unit and Fixed/Drive/Direct Frame/1st Lens Frame/2nd Lens Frame Move Unit

• Screw(C) × 3

- Align the flex insert part of fixed frame unit and convex of the master flange unit, and then insert the master flange unit.

Flex  
Flex insert part  
Master Flange Unit  
Fixed/Drive/Direct/1st Lens Frame/2nd Lens Frame Move Unit  
Convex  
Flex insert part

**NOTE: (When Assembling)**

- Take care not to damage the flex.
- Refer to "THE APPLYMENT OF GREASE METHOD" when installing the master flange unit.

Shutter  
LE 2A

- Turn the Drive Gear in the direction of an arrow, and then confirm the lens shutter is closed.

Screw(C)  
Drive Gear

Screw(C)  
4mm  
SILVER

### 8.6. Removal of the CCD Unit

To prevent the CCD unit from catching the dust and dirt, do not remove the CCD unit except for replacing.

• Screw(D) × 3      • Optical Filter × 1  
• CCD Cushion × 1

CCD Unit  
Screw(D)

Screw(D)  
3mm  
BLACK

CCD side (red is pale)  
Lens side (red is deep)  
CCD Cushion  
Optical Filter

**NOTE: (When Assembling)**

Definitions of mount side of Optical filter.

- \*Set the optical filter under the condition of reflecting the fluorescent lamp can be seen by your eyes.
- \*Although depth of the red color may be changed in accordance with seeing angle, compare the deepest red color in both sides to define each side.  
Lens side: red color is deeper than the other side.  
CCD side: red color is paler than the other side.
- It can be easy to confirm the red color density on the blue paper.
- \*The optical filter might stuck to CCD unit.  
When replace the CCD unit, remove the optical filter, and then install it with CCD unit.

## 8.7. Removal of the Focus Motor Unit

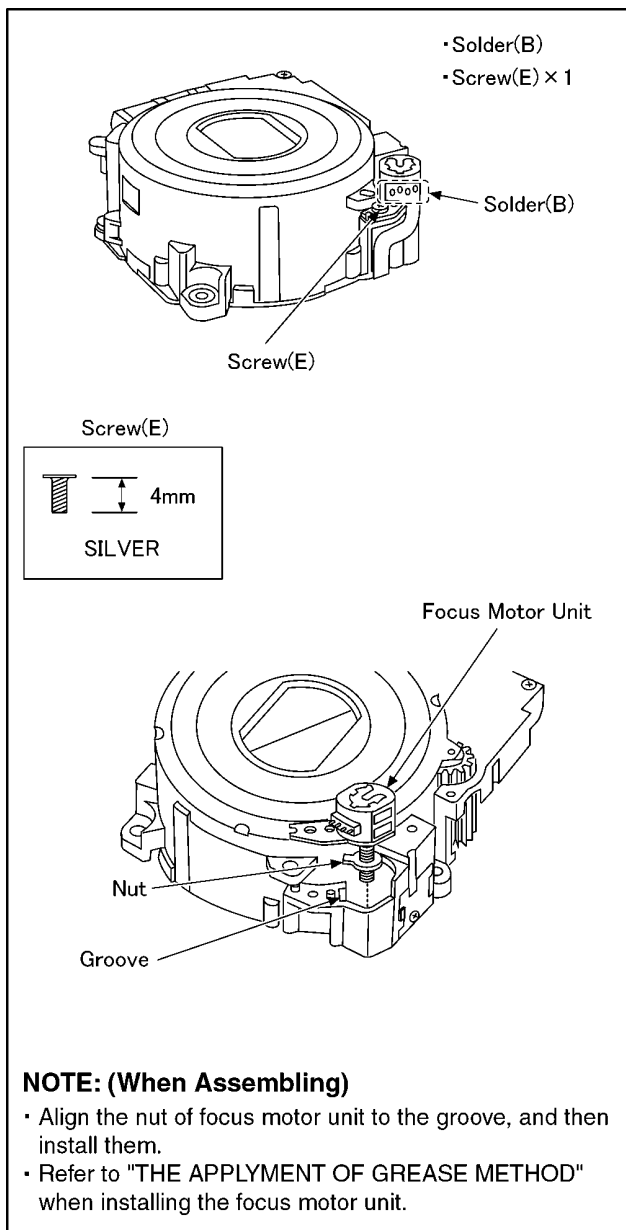

## 8.8. The Applyment of Grease Method

The grease apply point of lens unit are as follows.

Apply grease additionally in the specified position if necessary.  
When the grease is applied, use a toothpick and apply thinly.

- Guide pole L,S/Fasten groove of nut/Focus motor unit (Lead screw)
  - Grease: RFKZ0472
  - Amount of apply: 2 - 4 mg

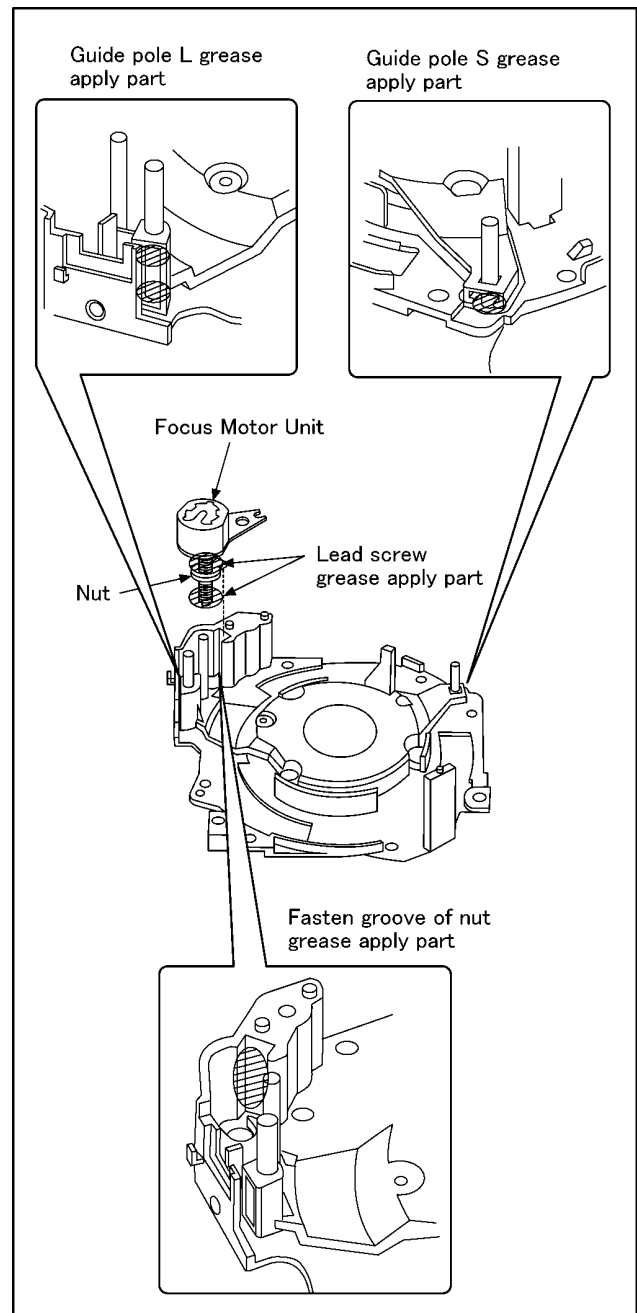



# 9 Measurements and Adjustments

## 9.1. Matrix Chart for Replaced Part and Necessary Adjustment

The relation between Replaced part and Necessary Adjustment is shown in the following table.

When concerned part is replaced, be sure to achieve the necessary adjustment(s).

As for Adjustment condition/procedure, consult the "Adjustment Manual" which is available in Adjustment software.

The Adjustment software is available at "TSN Website", therefore, access to "TSN Website" at "Support Information from NWBG/VDBG-AVC".

**NOTE:**

After adjustments have been terminated, make sure to achieve "INITIAL SETTINGS".

Adjustment Item		Replaced Part				
		Main P.C.B.	VENUS (IC6001)	Flash-ROM (IC6002)	Lens Part (Excluding CCD)	CCD Unit
Camera Section	OIS hall element adjustment (OIS)	○	○	○	○	-
	Back focus adjustment (BF)	○	○	○	○	○*1
	Shutter adjustment (SHT)	○	○	○	○	○
	ISO sensitivity adjustment (ISO)	○	○	○	○	○
	AWB adjustment High brightness coloration inspection (WBL)	○	○	○	○	○
	CCD white scratch compensation (WKI)	○	○	○	-	○*1
	CCD black scratch compensation (BKI)	○	○	○	-	○*1
	Venus zoom inspection (PZM)	○	○	○	-	-
	Monitor linearity inspection (MLN)	○	○	○	○	○
	Colour reproduction inspection, MIC inspection (COL)	○	○	○	○	○

\*1: This adjustment is necessary, not only replacing CCD unit but also removing it from the lens unit.

**NOTE:**

\*There is no LCD adjustment in this model.

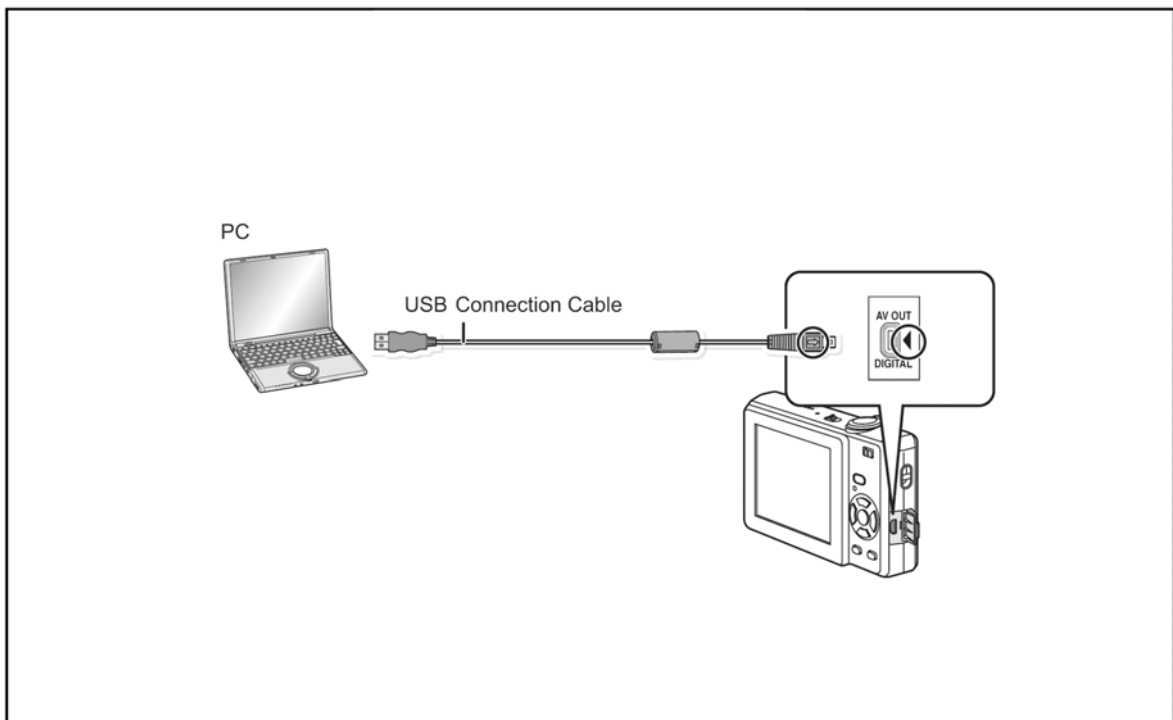

# 10 Maintenance

## 10.1. Cleaning Lens and LCD Panel

Do not touch the surface of lens and LCD Panel with your hand.

When cleaning the lens, use air-Blower to blow off the dust.

When cleaning the LCD Panel, dampen the lens cleaning paper with lens cleaner, and the gently wipe the their surface.

**Note:**

The Lens Cleaning KIT ; VFK1900BK (Only supplied as 10 set/Box) is available as Service Aid.

# Service Manual

---

## Diagrams and Replacement Parts List

### Digital Camera

Model No.

DMC-FS15P	DMC-FS15EG
DMC-FS15PC	DMC-FS15EP
DMC-FS15PR	DMC-FS15GC
DMC-FS15PU	DMC-FS15GJ
DMC-FS15EB	DMC-FS15GK
DMC-FS15EE	DMC-FS15GN
DMC-FS15EF	DMC-FS15GT

Vol. 1  
 Colour  
 (S).....Silver Type (except PC/PR/EF/GJ)  
 (K).....Black Type  
 (A).....Blue Type (except PR/EF/GJ/GK/GN/GT)

### Table of contents

S1. About Indication of The Schematic Diagram ..... S-1  
 S1.1. Important Safety Notice..... S-1

S2. Voltage Chart ..... S-2  
 S2.1. Flash Top P.C.B..... S-2

S3. Block Diagram..... S-3  
 S3.1. Overall Block Diagram ..... S-3

S4. Schematic Diagram..... S-4  
 S4.1. Interconnection Diagram ..... S-4  
 S4.2. Flash Top Schematic Diagram ..... S-5  
 S4.3. CCD Flex Schematic Diagram ..... S-6  
 S4.4. Lens Flex Schematic Diagram ..... S-7

S5. Print Circuit Board..... S-8  
 S5.1. Flash Top P.C.B..... S-8  
 S5.2. CCD Flex P.C.B..... S-9  
 S5.3. Lens Flex P.C.B..... S-10

S6. Replacement Parts List..... S-11

S7. Exploded View ..... S-16  
 S7.1. Frame and Casing Section..... S-16  
 S7.2. Camera Lens Section..... S-17  
 S7.3. Packing Parts and Accessories Section (1) ..... S-18  
 S7.4. Packing Parts and Accessories Section (2) ..... S-19

## S1. About Indication of The Schematic Diagram

### S1.1. Important Safety Notice

COMPONENTS IDENTIFIED WITH THE MARK  $\triangle$  HAVE THE SPECIAL CHARACTERISTICS FOR SAFETY. WHEN REPLACING ANY OF THESE COMPONENTS USE ONLY THE SAME TYPE.

1. Although reference number of the parts is indicated on the P.C.B. drawing and/or schematic diagrams, it is NOT mounted on the P.C.B. when it is displayed with "\$" mark.
2. It is only the "Test Round" and no terminal (Pin) is available on the P.C.B. when the TP (Test Point) indicated as "●" mark.
3. The voltage being indicated on the schematic diagram is measured in "Standard-Playback" mode when there is no specify mode is mentioned.
4. Although the voltage and waveform available on here is measured with standard frame, it may be differ from actual measurement due to modification of circuit and so on.
5. The voltage being indicated here may be include observational-error (deviation) due to internal-resistance and/or reactance of equipment. Therefore, handle the value indicated on here as reference.
6. Use the parts number indicated on the Replacement Parts List .
7. Indication on Schematic diagrams:

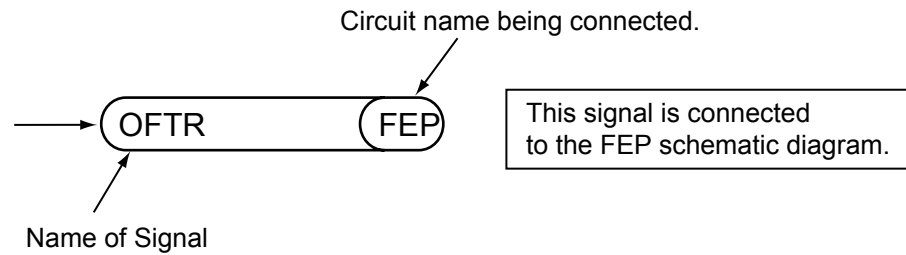

## S2. Voltage Chart

Note) Indicated voltage values are the standard values for the unit measured by the DC electronic circuit tester (high-impedance) with the chassis taken as standard.  
Therefore, there may exist some errors in the voltage values, depending on the internal impedance of the DC circuit tester.

### S2.1. Flash Top P.C.B.

REF No.	PIN No.	POWER ON
IC8001	1	5.8
IC8001	2	0
IC8001	3	0
IC8001	4	0
IC8001	5	5.8
Q8009	1	6.9
Q8009	2	6.9
Q8009	3	0
Q8009	4	0
Q8009	5	6.9
Q8009	6	6.9

# S3. Block Diagram

## S3.1. Overall Block Diagram

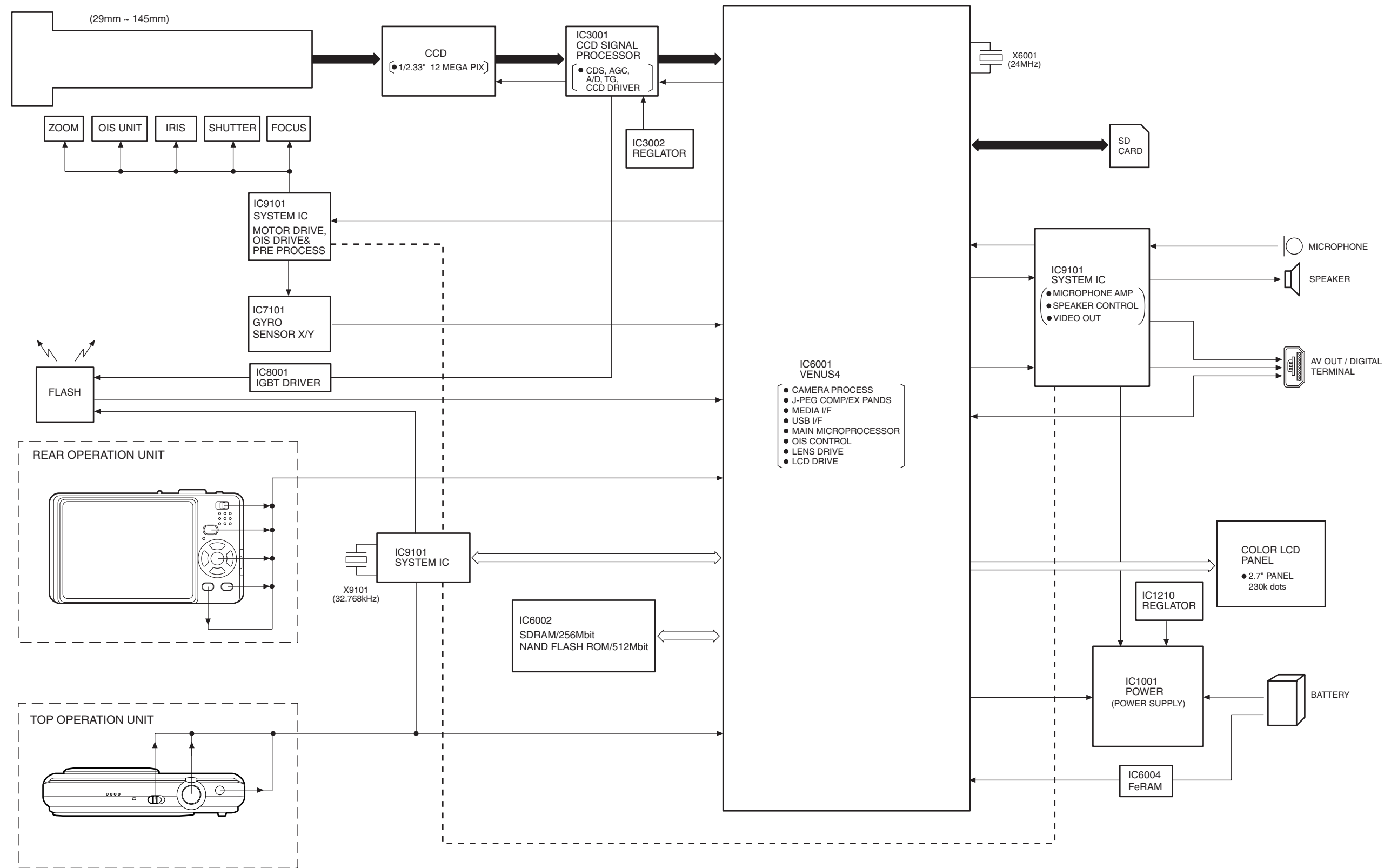

# S4. Schematic Diagram

## S4.1. Interconnection Diagram

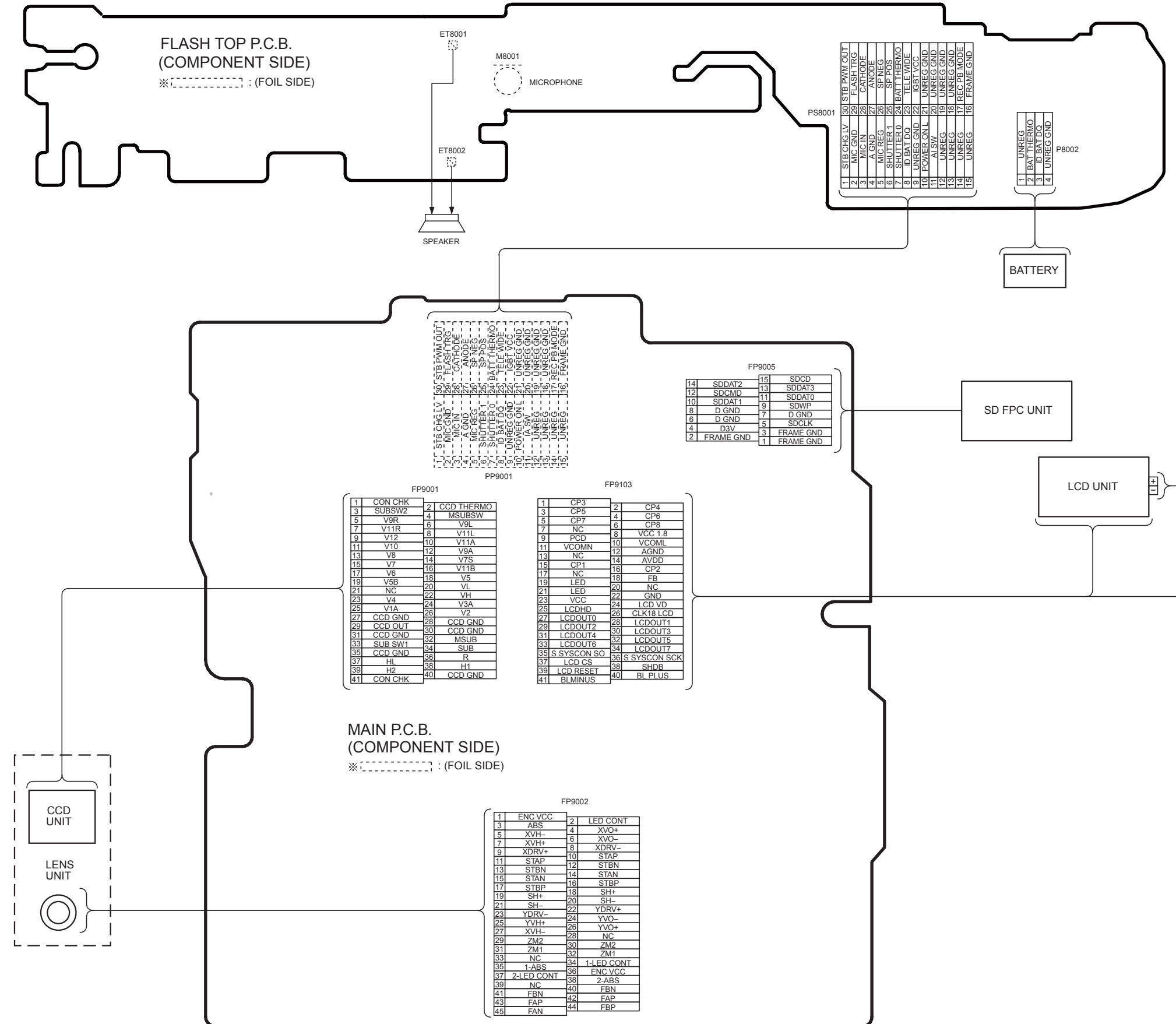

# S4.2. Flash Top Schematic Diagram

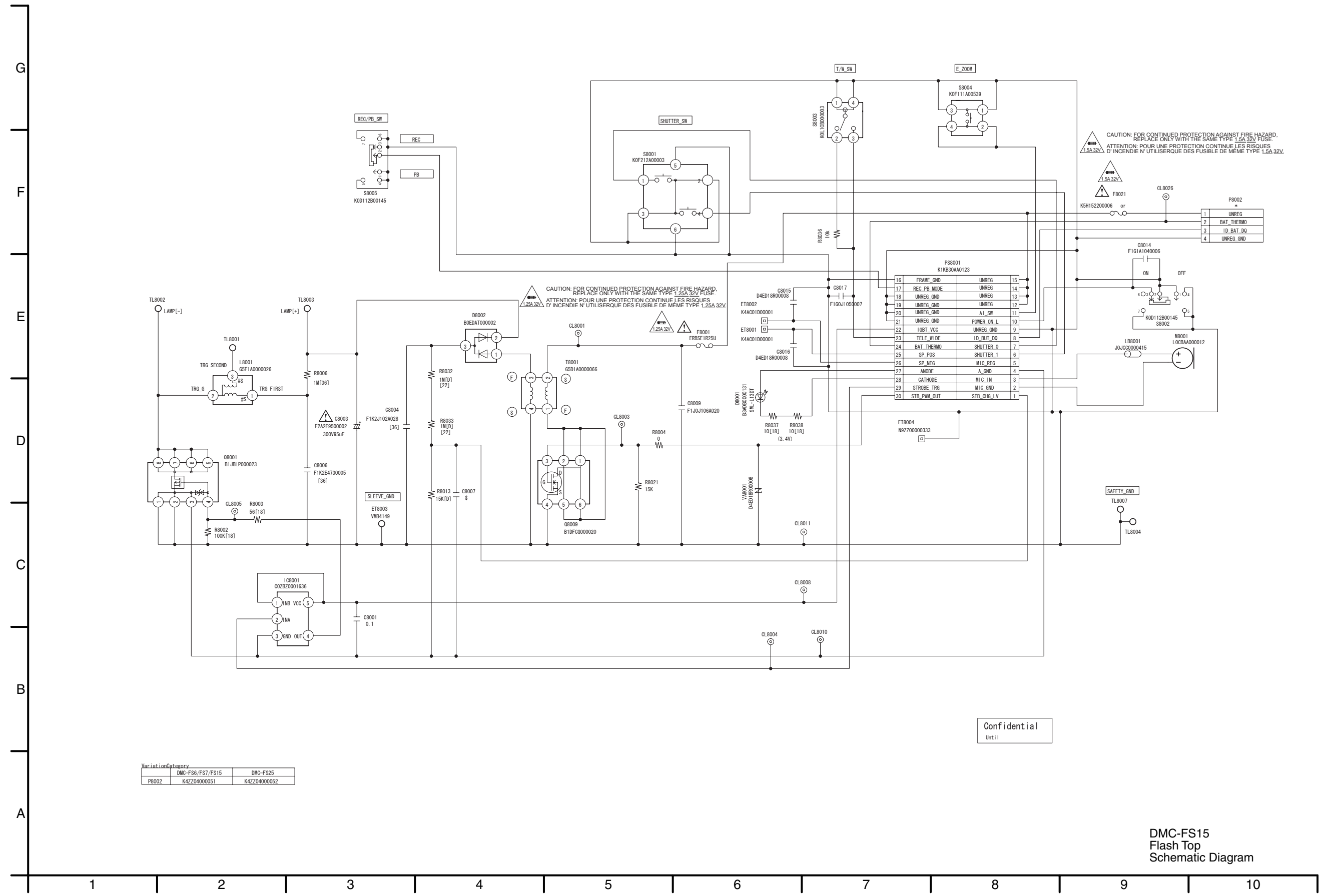

VariationCategory	DMC-FS6/FS7/FS15	DMC-FS25
P8002	K42Z04000051	K42Z04000052

Confidential  
 Unt:1

DMC-FS15  
 Flash Top  
 Schematic Diagram

### S4.3. CCD Flex Schematic Diagram

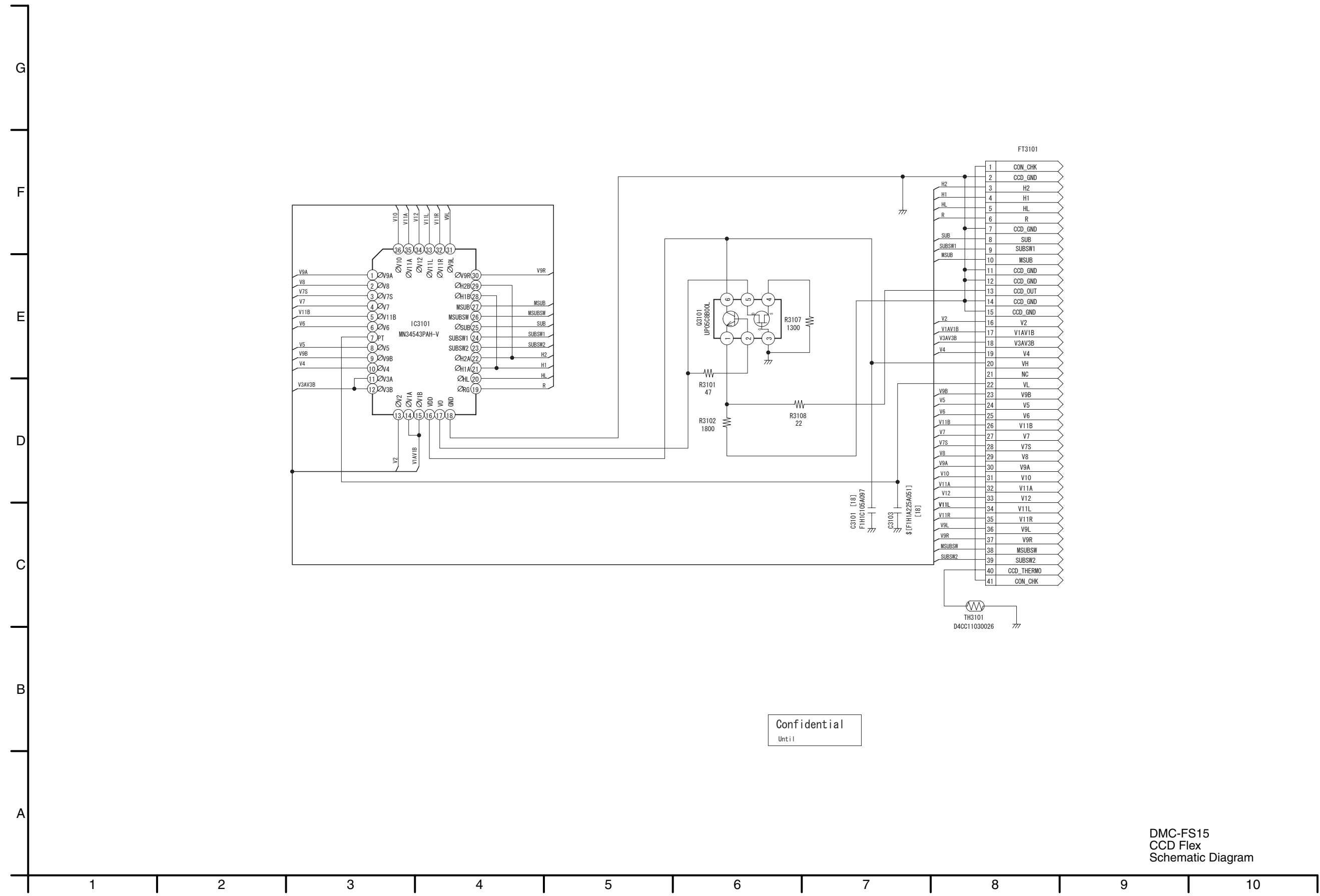

Confidential  
Until



### S4.4. Lens Flex Schematic Diagram

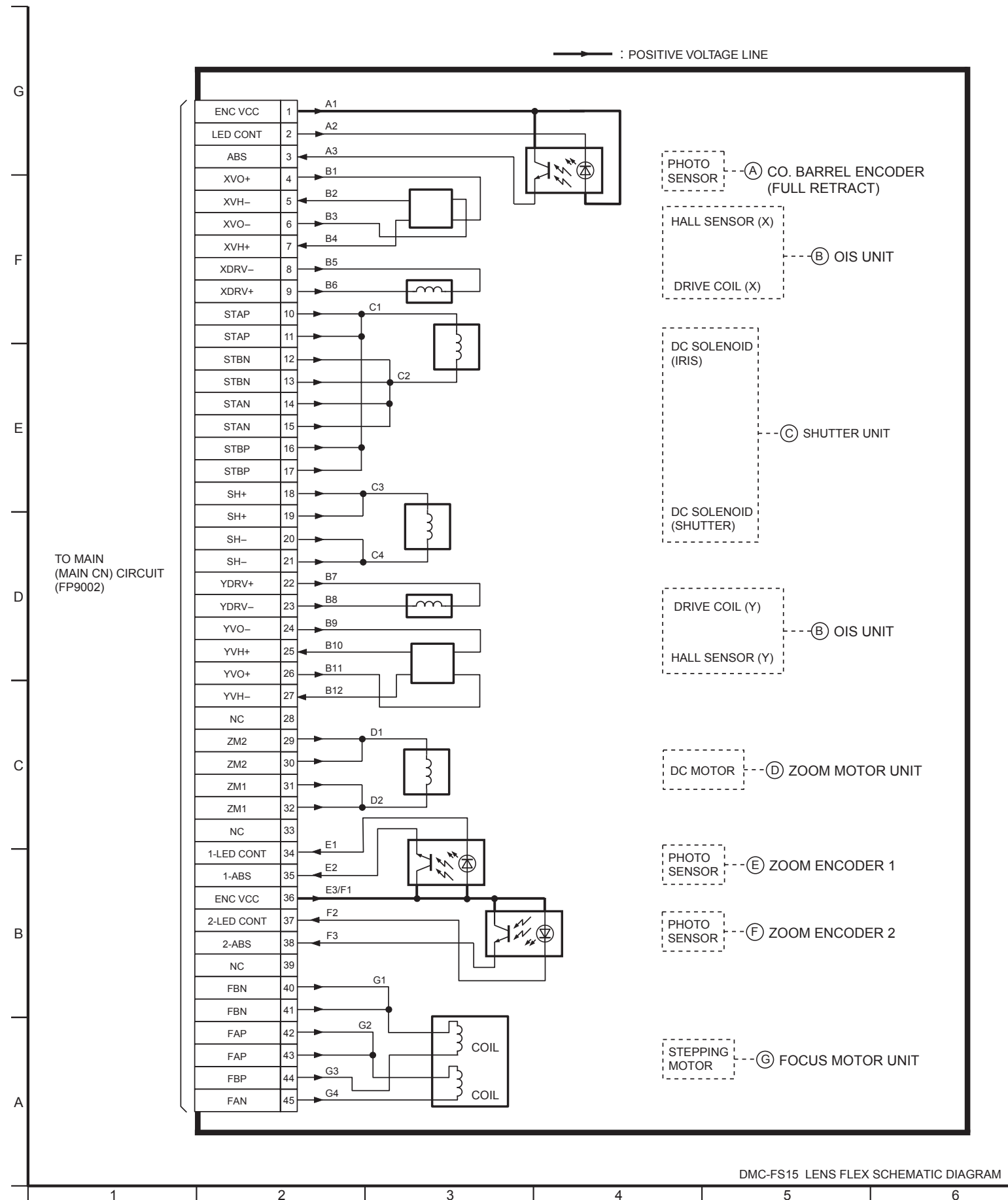

# S5. Print Circuit Board

## S5.1. Flash Top P.C.B.

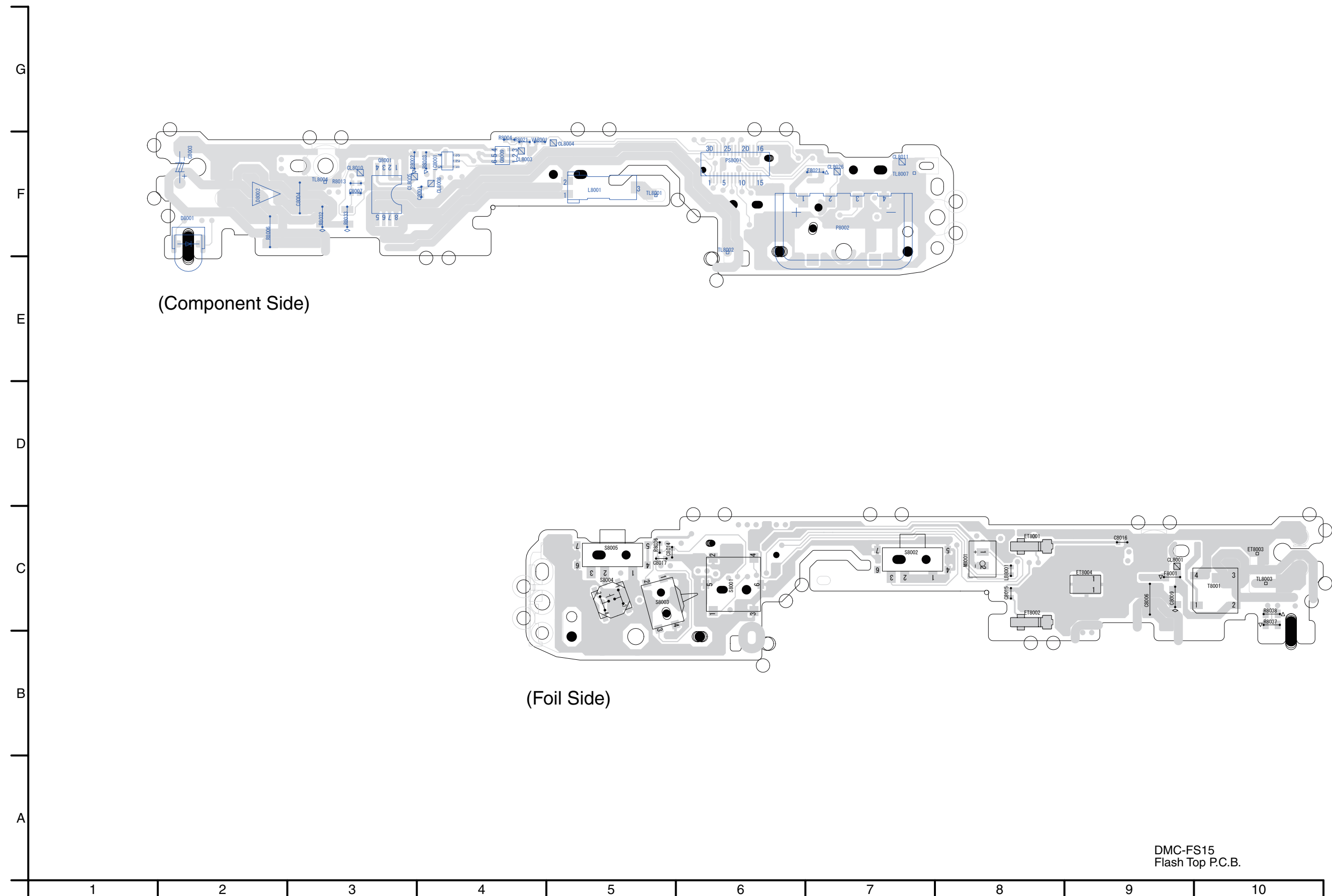

DMC-FS15  
Flash Top P.C.B.

S5.2. CCD Flex P.C.B.

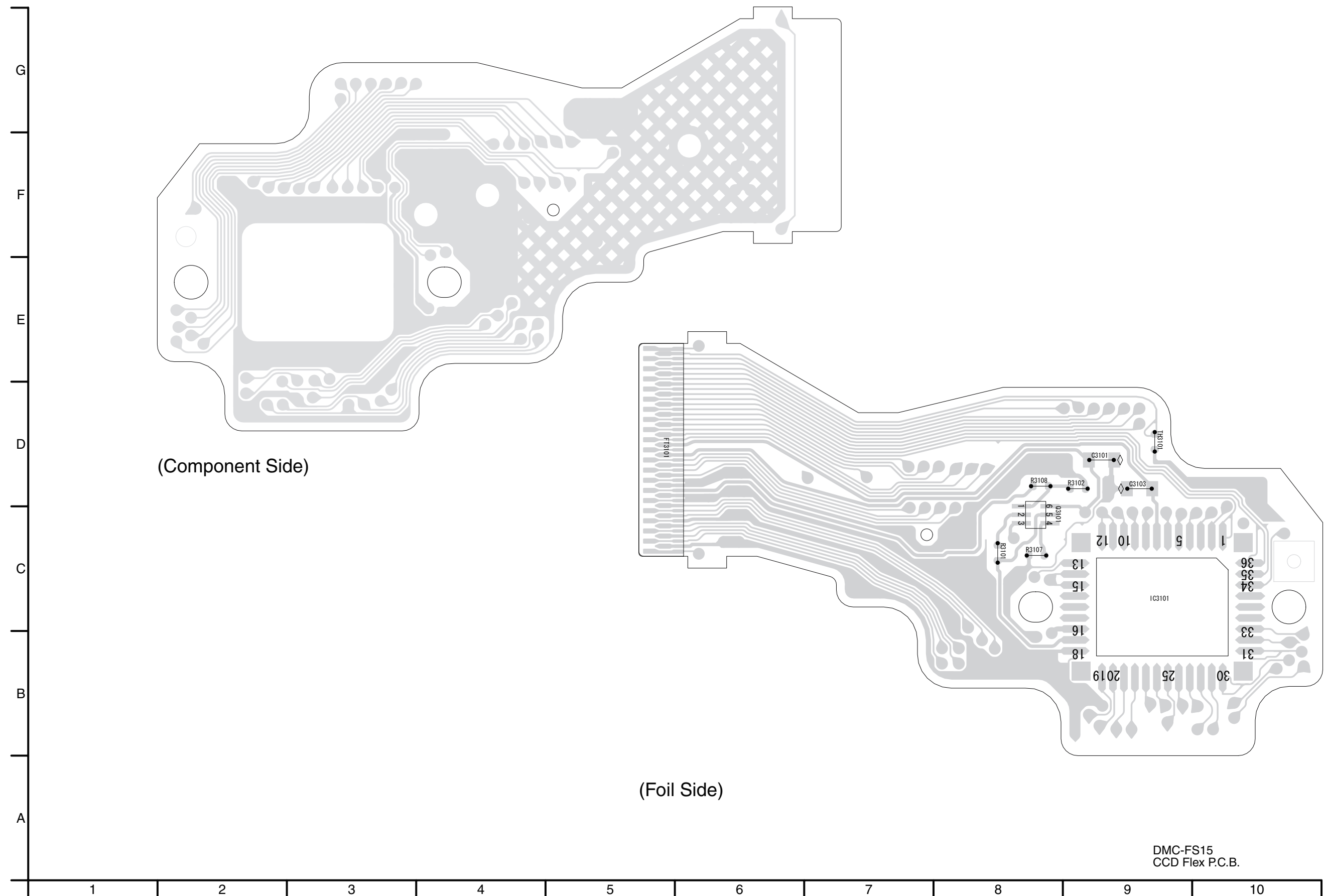

S5.3. Lens Flex P.C.B.

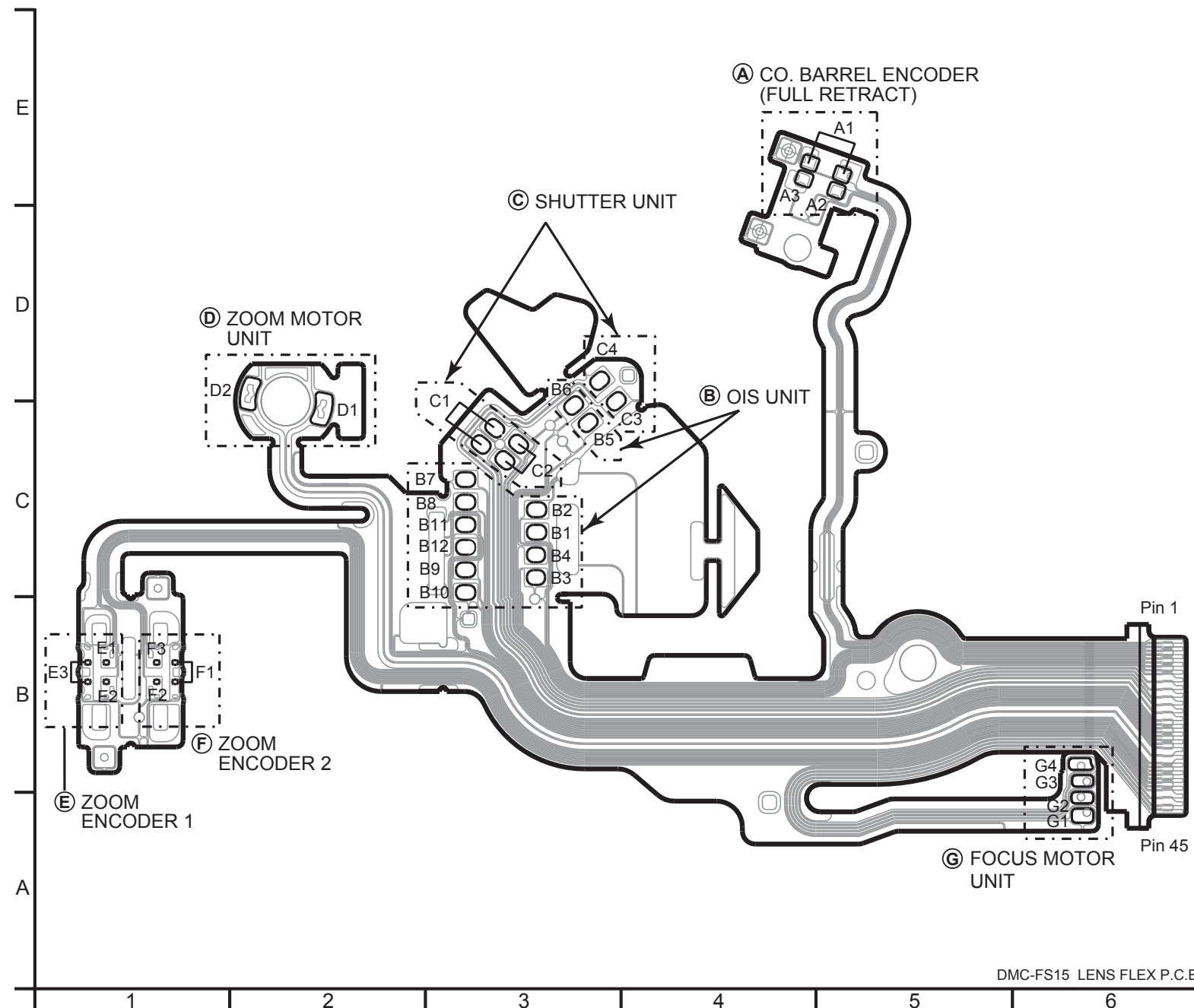

## S6. Replacement Parts List

- Note:
1. \* Be sure to make your orders of replacement parts according to this list.
  2. **IMPORTANT SAFETY NOTICE**  
Components identified with the mark  have the special characteristics for safety. When replacing any of these components, use only the same type.
  3. Unless otherwise specified,  
All resistors are in OHMS, K=1,000 OHMS. All capacitors are in MICRO-FARADS (uf), P=uuF.
  4. The marking (RTL) indicates the retention time is limited for this item. After the discontinuation of this assembly in production, it will no longer be available.
  5. Supply of CD-ROM, in accordance with license protection, is allowable as replacement parts only for customers who accidentally damaged or lost their own.

**E.S.D. standards for Electrostatically Sensitive Devices, refer to PREVENTION OF ELECTROSTATIC DISCHARGE (ESD) TO ELECTROSTATICALLY SENSITIVE (ES) DEVICES section.**

**Definition of Parts supplier:**

1. Parts marked with [ENERGY] in the remarks column are supplied from Panasonic Corporation Energy Company.
2. Parts marked with [SPC] in the remarks column are supplied from AVC-CSC-SPC. Others are supplied from PAVCSG.

DMC-FS15P/PC/PR/PU/EB/EE/EF/EG/EP/GC/GJ/GK/GN/GT  
VEP58076A / VEK0N44

Ref.No.	Part No.	Part Name & Description	Pcs	Remarks
		----- P.C.B. LIST -----		
	VEP56075A	MAIN P.C.B.		(RTL) E.S.D.
	VEP58076A	FLASH TOP P.C.B.		(RTL) E.S.D.
	VEK0N44	CCD UNIT		[SPC] E.S.D.
		-- INDIVIDUAL PARTS --		
△ C8003	F2A2F9500002	E.CAPACITOR		
ET8003	VMB4149	EARTH SPRING		
		-- ELEC. COMPONENTS --		
#	VEP58076A	FLASH TOP P.C.B.		(RTL) E.S.D.
C8001	F1G1A1040006	C.CAPACITOR CH 10V 0.1U	1	
C8004	F1K2J102A028	C.CAPACITOR 630V 1000P	1	
C8006	F1K2E4730005	C.CAPACITOR 250V 0.047U	1	
C8009	F1J0J106A020	C.CAPACITOR CH 6.3V 10U	1	
C8014	F1G1A1040006	C.CAPACITOR CH 10V 0.1U	1	
C8015	D4ED18R00008	VARISTOR	1	
C8016	D4ED18R00008	VARISTOR	1	
C8017	F1G0J1050007	C.CAPACITOR CH 6.3V 1U	1	
D8001	B3ADB0000131	DIODE	1	E.S.D.
D8002	B0EDAT000002	DIODE	1	E.S.D.
ET8001	K4AC01D00001	EARTH SPRING	1	
ET8002	K4AC01D00001	EARTH SPRING	1	
ET8004	N9ZZ00000333	EARTH SPRING	1	
△ F8001	ERBSE1R25U	FUSE 32V 1.25A	1	
△ F8021	K5H152200006	FUSE	1	
IC8001	C0ZBZ0001636	IC	1	E.S.D.
L8001	G5F1A0000026	CHIP INDUCTOR	1	
LB8001	J0JCC0000415	FILTER	1	
M8001	L0CBAA000012	MICROPHONE	1	
P8002	K4ZZ04000051	CONNECTOR 4P	1	
PS8001	K1KB30AA0123	CONNECTOR 30P	1	
Q8001	B1JBLP000023	TRANSISTOR	1	E.S.D.
Q8009	B1DFCG000020	TRANSISTOR	1	E.S.D.
R8002	ERJ3GEYJ104V	M.RESISTOR CH 1/10W 100K	1	
R8003	ERJ3GEYJ560V	M.RESISTOR CH 1/10W 56	1	
R8004	ERJ2GE0R00X	M.RESISTOR CH 1/16W 0	1	
R8006	ERJ8GEYJ105V	M.RESISTOR CH 1/8W 1M	1	
R8013	ERJ2RHD153X	M.RESISTOR CH 1/16W 15K	1	
R8021	ERJ2GEJ153X	M.RESISTOR CH 1/16W 15K	1	
R8032	ERJ6RED105V	M.RESISTOR CH 1/16W 1M	1	
R8033	ERJ6RED105V	M.RESISTOR CH 1/16W 1M	1	
R8036	ERJ2GEJ103X	M.RESISTOR CH 1/16W 10K	1	
R8037	ERJ3GEYJ100V	M.RESISTOR CH 1/10W 10	1	
R8038	ERJ3GEYJ100V	M.RESISTOR CH 1/10W 10	1	
S8001	K0F212A00003	SWITCH	1	
S8002	K0D112B00145	SWITCH	1	
S8003	K0L1CB000003	SWITCH	1	
S8004	K0F111A00539	SWITCH	1	
S8005	K0D112B00145	SWITCH	1	
T8001	G5D1A0000066	TRANSFORMER	1	
VA8001	D4ED18R00008	VARISTOR	1	

Ref.No.	Part No.	Part Name & Description	Pcs	Remarks
#	VEK0N44	CCD UNIT		[SPC] E.S.D.
C3101	F1H1C105A097	C.CAPACITOR CH 16V 1U	1	[SPC]
Q3101	UP05C8B00L	TRANSISTOR	1	[SPC] E.S.D.
R3101	ERJ2GEJ470	M.RESISTOR CH 1/16W 47	1	[SPC]
R3102	ERJ2GEJ182	M.RESISTOR CH 1/16W 1.8K	1	[SPC]
R3107	ERJ2GEJ132	M.RESISTOR CH 1/16W 1.3K	1	[SPC]
R3108	ERJ2GEJ220	M.RESISTOR CH 1/16W 22	1	[SPC]
TH3101	D4CC11030026	NTC THERMISTORS	1	[SPC]

DMC-FS15P/PC/PR/PU/EB/EE/EF/EG/EP/GC/GJ/GK/GN/GT

Ref.No.	Part No.	Part Name & Description	Pcs	Remarks	Ref.No.	Part No.	Part Name & Description	Pcs	Remarks
1	VEP56075A	MAIN P.C.B.	1	(RTL) E.S.D.	100	VXW1024	LENS UNIT(W/O CCD)	1	[SPC]
A 2	ML-421S/DN	BUTTON BATTERY	1	(B9101)[ENERGY]	101	VDL2046	OPTICAL FILTER	1	[SPC]
3	VEK0N16	SD FPC UNIT	1		102	VEK0N44	CCD UNIT	1	[SPC] E.S.D.
4	VGK3489	SIDE ORNAMENT L	1		103	VMX3650	CCD CUSHION	1	[SPC]
5	VGK3490	SIDE ORNAMENT R	1		104	VXP3105	1ST LENS FRAME UNIT	1	[SPC]
6	VKF4429	JACK DOOR	1		105	VXP3146	FIX/DRIVE/DIRECT FRAME UNIT	1	[SPC]
7	VYK2Z05	FRONT CASE UNIT	1	(-S)	109	L6DA8BEC0003	ZOOM MOTOR	1	[SPC]
7	VYK2Z12	FRONT CASE UNIT	1	(-K)	110	VXP3110	2ND LENS FRAME UNIT	1	[SPC]
7	VYK2Z14	FRONT CASE UNIT	1	(-A)	113	VXQ1699	MASTER FLANGE UNIT	1	[SPC]
8	VYK2Z06	BATTERY DOOR UNIT	1	(-S)	113-1	L6HA64NC0014	FOCUS MOTOR UNIT	1	[SPC]
8	VYK2Y29	BATTERY DOOR UNIT	1	(-K)	113-2	VMB4157	FOCUS SPRING	1	[SPC]
8	VYK2Z16	BATTERY DOOR UNIT	1	(-A)	113-3	VXP3101	3RD LENS FRAME UNIT	1	[SPC]
8-1	VMB4143	BATTERY DOOR SPRING	1		114	VEP50024A	LENS FPC UNIT	1	[SPC]
8-2	VMS7863	BATTERY DOOR SHAFT	1		114-1	B3NBA0000011	PHOTO SENSOR	1	[SPC]
9	VYK2Z07	REAR CASE UNIT	1	(-S)	114-2	B3NBA0000011	PHOTO SENSOR	1	[SPC]
9	VYK2Z13	REAR CASE UNIT	1	(-K)	114-3	B3NBA0000011	PHOTO SENSOR	1	[SPC]
9	VYK2Z15	REAR CASE UNIT	1	(-A)					
9-1	VGL1288	REAR PANEL LIGHT	1		B100	VHD1871	SCREW	1	[SPC]
9-2	VGU0D72	CORSOR BUTTTON	1		B101	VHD1871	SCREW	1	[SPC]
10	VGQ0B87	PCB SPACER	1		B102	VHD1871	SCREW	1	[SPC]
13	VGQ9717	BATTERY LOCK KNOB	1		B103	XQN14+CJ4FN	SCREW	1	[SPC]
14	VMB4152	BATTERY LOCK SPRING	1		B104	XQN14+CJ4FN	SCREW	1	[SPC]
15	VMB4222	BATTERY OUT SPRING	1		B105	XQN14+CJ4FN	SCREW	1	[SPC]
16	VMP9238	FRAME	1		B106	XQN14+CJ4FN	SCREW	1	[SPC]
17	VMP9369	FRAME PLATE	1		B107	VHD2011	SCREW	1	[SPC]
18	VMP9240	TRIPOD	1		B108	XQN14+CJ4FN	SCREW	1	[SPC]
19	VMP9242	EARTH PLATE	1		B109	XQN14+CJ4FN	SCREW	1	[SPC]
20	VYK2W99	BATTERY CASE UNIT	1						
A 21	F2A2F9500002	E.CAPACITOR	1	(C8003)					
22	L0AA01A00032	SPEAKER UNIT	1						
23	VEK0N43	FLASH UNIT	1						
24	VEP58076A	FLASH TOP P.C.B.	1	(RTL) E.S.D.					
25	VGL1290	AF PANEL LIGHT	1						
26	VGQ0B86	POWER KNOB BASE	1						
27	VYK3H29	TOP ORNAMENT UNIT	1						
28	VGU0C05	REC/PLAYBACK SELECTOR KNOB	1						
29	VGU0E68	POWER KNOB	1						
30	VGU0D76	IA BUTTON	1						
31	VMB4149	EARTH SPRING	1	(ET8003)					
32	VMP9243	TOP PLATE L	1						
33	VMT1968	MIC DAMPER	1						
34	VYK3H33	LCD UNIT	1						
34-1	VYK3G47	LCD PANEL UNIT	1						
35	VMX3700	LCD CUSHION	1						
36	VGQ0F16	EARTH PLATE TAPE	1						
B1	VHD2081	SCREW	1	(-S,-A)					
B1	VHD2082	SCREW	1	(-K)					
B2	VHD2081	SCREW	1	(-S,-A)					
B2	VHD2082	SCREW	1	(-K)					
B3	VHD2081	SCREW	1	(-S,-A)					
B3	VHD2082	SCREW	1	(-K)					
B4	VHD2083	SCREW	1						
B5	VHD2083	SCREW	1						
B6	VHD2084	SCREW	1						
B7	VHD1998	SCREW	1						
B8	VHD1998	SCREW	1						
B9	XQN16+BJ7FN	SCREW	1						
B10	XQN16+BJ7FN	SCREW	1						
B11	XQN16+BJ7FN	SCREW	1						
B12	VHD1998	SCREW	1						
B13	VHD1998	SCREW	1						





DMC-FS15P/PC/PR/PU/EB/EE/EF/EG/EP/GC/GJ/GK/GN/GT  
MM

Ref.No.	Part No.	Part Name & Description	Pcs	Remarks	Ref.No.	Part No.	Part Name & Description	Pcs	Remarks
300	VPF1302	CAMERA BAG	1	EXCEPT P,PC,PU	326	VQT1W20	O/I SOFTWARE	1	GC,GJ
△ 301	DE-A60DA/SX	BATTERY CHARGER	1	PR			(ENGLISH/CHINESE(TRADITIONAL)/		
△ 301	DE-A60AA/SX	BATTERY CHARGER	1	EB,EF,EG,EP,GN			ARABIC/PERSIAN)		
△ 301	DE-A60BA/SX	BATTERY CHARGER	1	EE,GC,GJ,GK	326	VQT1W23	O/I SOFTWARE	1	GK
△ 301	DE-A60CA/SX	BATTERY CHARGER	1	GT			(CHINESE(SIMPLIFIED))		
△ 302	-----	BATTERY	1	EXCEPT P,PC,PU	326	VQT1W22	O/I SOFTWARE	1	GT
304	K1HA08AD0002	USB CABLE W/PLUG	1	EXCEPT P,PC,PU			(CHINESE(TRADITIONAL))		
305	K1HA08CD00028	AV CABLE W/PLUG	1	EXCEPT P,PC,PU					
306	VFC4297-B	HAND STRAP	1	EXCEPT P,PC,PU					
307	VFF0445-S	CD-ROM	1	PR,EB,EE,EF,EG,EP,GC,GJ,					
				GN,GT See"Notes"[SPC]					
307	VFF0446-S	CD-ROM	1	GK See"Notes"[SPC]					
308	VGQ0D56	BATTERY PROTECTION CASE	1	EXCEPT P,PC,PU					
310	VPF1100	BAG, POLYETHYLENE	1	EXCEPT P,PC,PU					
314	VPK3715	PACKING CASE	1	EBS,EES,EGS,EPS,GCS,					
				GNS,GTS					
314	VPK3719	PACKING CASE	1	PRK,EBK,EEK,EFK,EGK,					
				EPK,GCK,GJK,GNK,GTK					
314	VPK3723	PACKING CASE	1	EBA,EEA,EGA,EPA,GCA					
314	VPK3716	PACKING CASE	1	GKS					
314	VPK3720	PACKING CASE	1	GKK					
315	VPN6663	CUSHION	1	PR,EB,EE,EF,EG,EP,GC,GJ,					
				GK,GN,GT					
318	VQL1G34-6A	OPERATING LABEL	1	GT					
△ 319	K2CT3CA00004	AC CORD W/PLUG	1	EB,GC					
△ 320	K2CQ2CA00006	AC CORD W/PLUG	1	EE,EF,EG,EP,GC					
△ 320	K2CP2Y00001	AC CORD W/PLUG	1	GJ					
△ 321	K2CJ2DA00008	AC CORD W/PLUG	1	GN					
△ 322	K2CA2CA000020	AC CORD W/PLUG	1	GK					
△ 322	K2CA2CA000027	AC CORD W/PLUG	1	GT					
△ 323	K2CJ2DA00006	AC CORD W/PLUG	1	PR					
△ 324	VFF0452-C	CD-ROM(INSTRUCTION BOOK)	1	PR,EG,EP					
△ 324	VFF0453-C	CD-ROM(INSTRUCTION BOOK)	1	GC,GJ					
△ 325	VQT1W33	SIMPLIFIED O/I	1	PR,EG					
		(SPANISH/PORTUGUESE)							
△ 325	VQT1W38	INSTRUCTION BOOK	1	EB					
		(ENGLISH)							
△ 325	VQT1W39	INSTRUCTION BOOK	1	EE					
		(RUSSIAN)							
△ 325	VQT1W40	INSTRUCTION BOOK	1	EE					
		(UKRAINIAN)							
△ 325	VQT1W37	INSTRUCTION BOOK	1	EF					
		(FRENCH)							
△ 325	VQT1W31	SIMPLIFIED O/I	1	EG					
		(GERMAN/FRENCH)							
△ 325	VQT1W32	SIMPLIFIED O/I	1	EG					
		(ITALIAN/DUTCH)							
△ 325	VQT1W36	SIMPLIFIED O/I	1	EP					
		(HUNGARIAN/FINNISH)							
△ 325	VQT1W35	SIMPLIFIED O/I	1	EP					
		(POLISH/CZECH)							
△ 325	VQT1W34	SIMPLIFIED O/I	1	EP					
		(SWEDISH/DANISH)							
△ 325	VQT1W42	SIMPLIFIED O/I	1	GC					
		(ARABIC/PERSIAN)							
△ 325	VQT1W41	SIMPLIFIED O/I	1	GC,GJ					
		(ENGLISH/CHINESE(TRADITIONAL))							
△ 325	VQT1W45	INSTRUCTION BOOK	1	GK					
		(CHINESE(SIMPLIFIED))							
△ 325	VQT1W46	INSTRUCTION BOOK	1	GN					
		(ENGLISH)							
△ 325	VQT1W44	INSTRUCTION BOOK	1	GT					
		(CHINESE(TRADITIONAL))							
326	VQT1W15	O/I SOFTWARE	1	PR,EG					
		(GERMAN/FRENCH/ITALIAN/							
		DUTCH/SPANISH/PORTUGUESE)							
326	VQT1W18	O/I SOFTWARE	1	EB,GN					
		(ENGLISH)							
326	VQT1W19	O/I SOFTWARE	1	EE					
		(RUSSIAN/UKRAINIAN)							
326	VQT1W17	O/I SOFTWARE	1	EF					
		(FRENCH)							
326	VQT1W16	O/I SOFTWARE	1	EP					
		(FINNISH/SWEDISH/DANISH/							
		POLISH/CZECH/HUNGARIAN)							

# S7. Exploded View

## S7.1. Frame and Casing Section

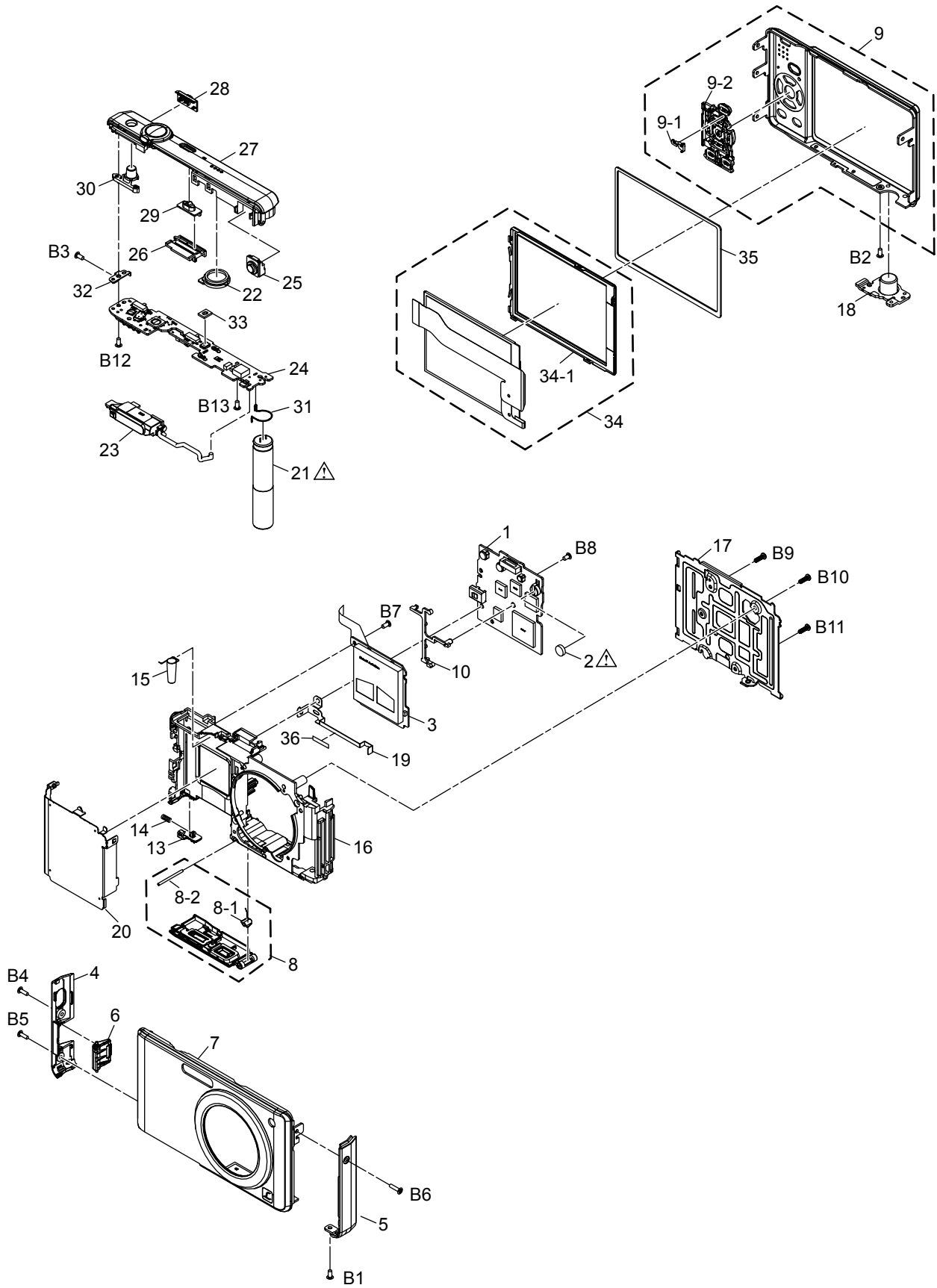

## S7.2. Camera Lens Section

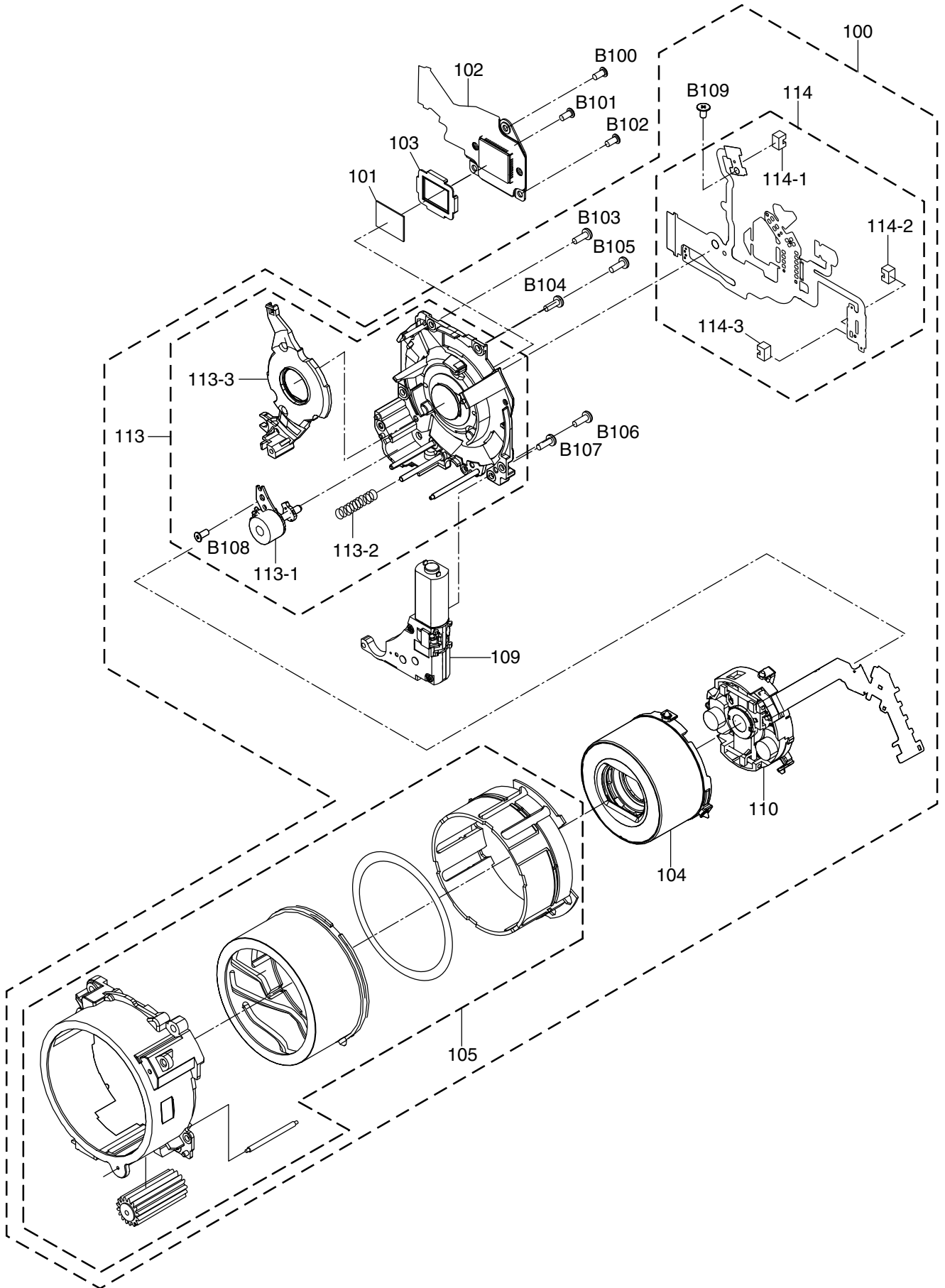

### S7.3. Packing Parts and Accessories Section (1)

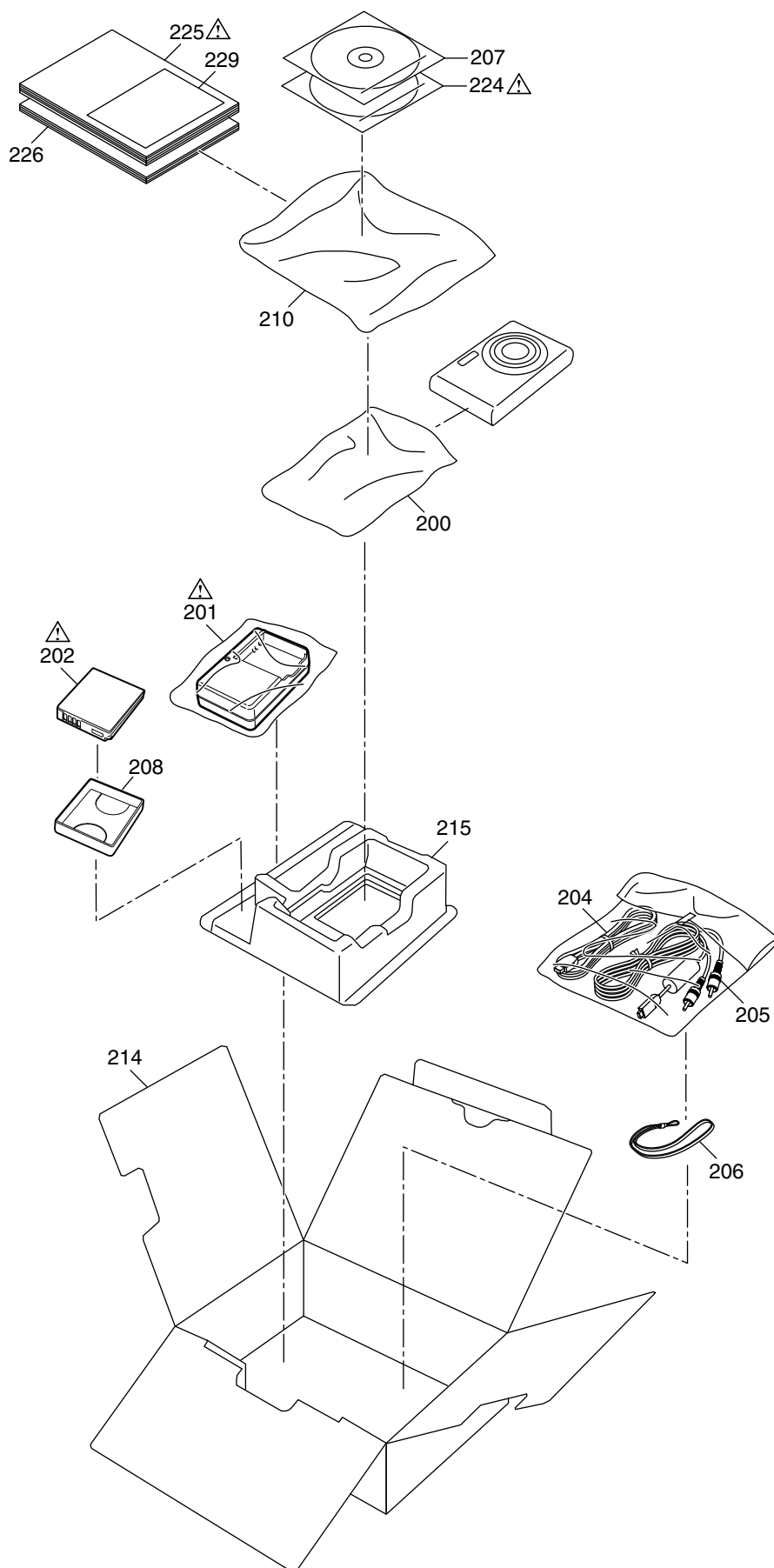

## S7.4. Packing Parts and Accessories Section (2)

