

# Service Manual

Digital Camera

LUMIX

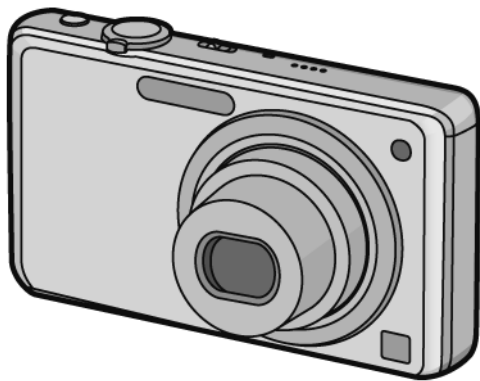

Model No. **DMC-FS30EB**  
**DMC-FS30EE**  
**DMC-FS30EF**  
**DMC-FS30EG**  
**DMC-FS30EP**  
**DMC-FH20P**  
**DMC-FH20PC**  
**DMC-FH20PR**  
**DMC-FH20PU**  
**DMC-FH20GC**  
**DMC-FH20GD**  
**DMC-FH20GF**  
**DMC-FH20GN**  
**DMC-FH20GT**

Vol. 1

Colour

[ DMC-FS30 ]

(S).....Silver Type (except EF)  
(K).....Black Type  
(A).....Blue Type (except EE)  
(V).....Violet Type

[ DMC-FH20 ]

(S).....Silver Type (except PR/GD/GT)  
(K).....Black Type  
(A).....Blue Type (except PC/PR/GD/GT)  
(V).....Violet Type (except PC/GF)  
(R).....Red Type (except GD/GN/GT)

**Panasonic**<sup>®</sup>

© Panasonic Corporation 2010 Unauthorized copying and distribution is a violation of law.

## **WARNING**

This service information is designed for experienced repair technicians only and is not designed for use by the general public. It does not contain warnings or cautions to advise non-technical individuals of potential dangers in attempting to service a product. Products powered by electricity should be serviced or repaired only by experienced professional technicians. Any attempt to service or repair the product or products dealt with in this service information by anyone else could result in serious injury or death.

# TABLE OF CONTENTS

	PAGE	PAGE
<b>1 Safety Precautions</b> .....	<b>3</b>	
1.1. General Guidelines .....	3	
1.2. Leakage Current Cold Check .....	3	
1.3. Leakage Current Hot Check (See Figure 1.) .....	3	
1.4. How to Discharge the Capacitor on Flash Top P.C.B. ....	4	
<b>2 Warning</b> .....	<b>5</b>	
2.1. Prevention of Electrostatic Discharge (ESD) to Electrostatically Sensitive (ES) Devices .....	5	
2.2. How to Recycle the Lithium Ion Battery (U.S. Only) .....	5	
2.3. Caution for AC Cord(For EB/GC) .....	6	
2.4. How to Replace the Lithium Battery .....	7	
<b>3 Service Navigation</b> .....	<b>8</b>	
3.1. Introduction .....	8	
3.2. General Description About Lead Free Solder (PbF) .....	8	
3.3. Important Notice 1:(Other than U.S.A. and Canadian Market) .....	8	
3.4. How to Define the Model Suffix (NTSC or PAL model) .....	9	
<b>4 Specifications</b> .....	<b>13</b>	
<b>5 Location of Controls and Components</b> .....	<b>14</b>	
<b>6 Service Mode</b> .....	<b>16</b>	
6.1. Error Code Memory Function .....	16	
6.2. ICS (Indication of additional Camera Settings when picture was taken) .....	18	
<b>7 Service Fixture &amp; Tools</b> .....	<b>20</b>	
7.1. Service Fixture and Tools .....	20	
7.2. When Replacing the Main P.C.B. ....	21	
7.3. Service Position .....	21	
<b>8 Disassembly and Assembly Instructions</b> .....	<b>22</b>	
8.1. Disassembly Flow Chart .....	22	
8.2. PCB Location .....	22	
8.3. Disassembly Procedure .....	23	
8.4. Lens Disassembly Procedure .....	28	
8.5. Assembly Procedure for the Lens .....	32	
8.6. Removal of the CCD Unit .....	38	
8.7. Removal of the Focus Motor Unit .....	38	
8.8. The Application of Grease Method .....	38	
<b>9 Measurements and Adjustments</b> .....	<b>39</b>	
9.1. Introduction .....	39	
9.2. Before Disassembling the unit .....	39	
9.3. Details of Electrical Adjustment .....	41	
9.4. After Adjustment .....	44	
<b>10 Maintenance</b> .....	<b>45</b>	
10.1. Cleaning Lens and LCD Panel .....	45	

# 1 Safety Precautions

## 1.1. General Guidelines

### 1. IMPORTANT SAFETY NOTICE

There are special components used in this equipment which are important for safety. These parts are marked by

 in the Schematic Diagrams, Circuit Board Layout, Exploded Views and Replacement Parts List. It is essential that these critical parts should be replaced with manufacturer's specified parts to prevent X-RADIATION, shock, fire, or other hazards. Do not modify the original design without permission of manufacturer.

2. An Isolation Transformer should always be used during the servicing of AC Adaptor whose chassis is not isolated from the AC power line. Use a transformer of adequate power rating as this protects the technician from accidents resulting in personal injury from electrical shocks. It will also protect AC Adaptor from being damaged by accidental shorting that may occur during servicing.
3. When servicing, observe the original lead dress. If a short circuit is found, replace all parts which have been overheated or damaged by the short circuit.
4. After servicing, see to it that all the protective devices such as insulation barriers, insulation papers shields are properly installed.
5. After servicing, make the following leakage current checks to prevent the customer from being exposed to shock hazards.

## 1.2. Leakage Current Cold Check

1. Unplug the AC cord and connect a jumper between the two prongs on the plug.
2. Measure the resistance value, with an ohmmeter, between the jumpered AC plug and each exposed metallic cabinet part on the equipment such as screwheads, connectors, control shafts, etc. When the exposed metallic part has a return path to the chassis, the reading should be between  $1\text{ M}\Omega$  and  $5.2\text{ M}\Omega$ . When the exposed metal does not have a return path to the chassis, the reading must be infinity.

## 1.3. Leakage Current Hot Check (See Figure 1.)

1. Plug the AC cord directly into the AC outlet. Do not use an isolation transformer for this check.
2. Connect a  $1.5\text{ k}\Omega$ ,  $10\text{ W}$  resistor, in parallel with a  $0.15\text{ }\mu\text{F}$  capacitor, between each exposed metallic part on the set and a good earth ground, as shown in Figure 1.
3. Use an AC voltmeter, with  $1\text{ k}\Omega/\text{V}$  or more sensitivity, to measure the potential across the resistor.
4. Check each exposed metallic part, and measure the voltage at each point.
5. Reverse the AC plug in the AC outlet and repeat each of the above measurements.
6. The potential at any point should not exceed  $0.75\text{ V RMS}$ . A leakage current tester (Simpson Model 229 or equivalent) may be used to make the hot checks, leakage current must not exceed  $1/2\text{ mA}$ . In case a measurement is outside of the limits specified, there is a possibility of a shock hazard, and the equipment should be repaired and rechecked before it is returned to the customer.

Hot-Check Circuit



Figure. 1

## 1.4. How to Discharge the Capacitor on Flash Top P.C.B.

### CAUTION:

1. Be sure to discharge the capacitor on FLASH TOP P.C.B..
2. Be careful of the high voltage circuit on FLASH TOP P.C.B. when servicing.

### [Discharging Procedure]

1. Refer to the disassemble procedure and remove the necessary parts/unit.
2. Install the insulation tube onto the lead part of resistor (ERG5SJ102:1k $\Omega$  /5W).  
(an equivalent type of resistor may be used.)
3. Place a resistor between both terminals of capacitor on the FLASH TOP P.C.B. for approx. 5 seconds.
4. After discharging, confirm that the capacitor voltage is lower than 10V using a voltmeter.

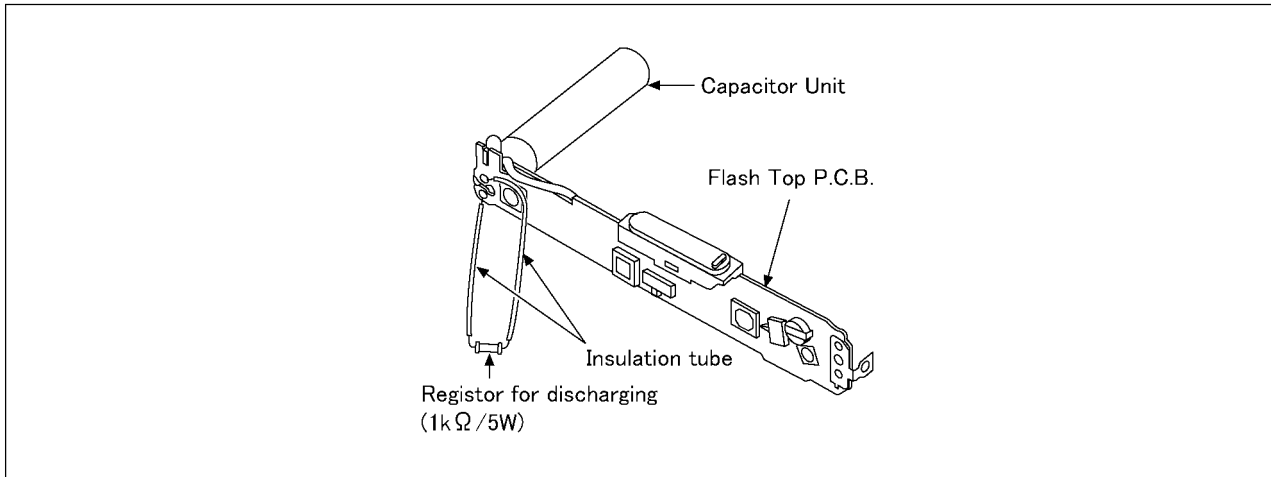

Fig. F1

## 2 Warning

### 2.1. Prevention of Electrostatic Discharge (ESD) to Electrostatically Sensitive (ES) Devices

Some semiconductor (solid state) devices can be damaged easily by static electricity. Such components commonly are called Electrostatically Sensitive (ES) Devices.

Examples of typical ES devices are CCD image sensor, IC (integrated circuits) and some field-effect transistors and semiconductor "chip" components.

The following techniques should be used to help reduce the incidence of component damage caused by electrostatic discharge (ESD).

1. Immediately before handling any semiconductor component or semiconductor-equipped assembly, drain off any ESD on your body by touching a known earth ground. Alternatively, obtain and wear a commercially available discharging ESD wrist strap, which should be removed for potential shock reasons prior to applying power to the unit under test.
2. After removing an electrical assembly equipped with ES devices, place the assembly on a conductive surface such as aluminum foil, to prevent electrostatic charge buildup or exposure of the assembly.
3. Use only a grounded-tip soldering iron to solder or unsolder ES devices.
4. Use only an antistatic solder removal device. Some solder removal devices not classified as "antistatic (ESD protected)" can generate electrical charge sufficient to damage ES devices.
5. Do not use freon-propelled chemicals. These can generate electrical charges sufficient to damage ES devices.
6. Do not remove a replacement ES device from its protective package until immediately before you are ready to install it. (Most replacement ES devices are packaged with leads electrically shorted together by conductive foam, aluminum foil or comparable conductive material).
7. Immediately before removing the protective material from the leads of a replacement ES device, touch the protective material to the chassis or circuit assembly into which the device will be installed.

**CAUTION :**

Be sure no power is applied to the chassis or circuit, and observe all other safety precautions.

8. Minimize bodily motions when handling unpackaged replacement ES devices. (Otherwise harmless motion such as the brushing together of your clothes fabric or the lifting of your foot from a carpeted floor can generate static electricity (ESD) sufficient to damage an ES device).

### 2.2. How to Recycle the Lithium Ion Battery (U.S. Only)

**ENGLISH**



A lithium ion battery that is recyclable powers the product you have purchased. Please call 1-800-8-BATTERY for information on how to recycle this battery.

**FRANÇAIS**



L'appareil que vous vous êtes procuré est alimenté par une batterie au lithium-ion recyclable. Pour des renseignements sur le recyclage de la batterie, veuillez composer le 1-800-8-BATTERY.

## 2.3. Caution for AC Cord (For EB/GC)

### 2.3.1. Information for Your Safety

#### IMPORTANT

Your attention is drawn to the fact that recording of pre-recorded tapes or discs or other published or broadcast material may infringe copyright laws.

#### WARNING

To reduce the risk of fire or shock hazard, do not expose this equipment to rain or moisture.

#### CAUTION

To reduce the risk of fire or shock hazard and annoying interference, use the recommended accessories only.

#### FOR YOUR SAFETY

##### DO NOT REMOVE THE OUTER COVER

To prevent electric shock, do not remove the cover. No user serviceable parts inside. Refer servicing to qualified service personnel.

### 2.3.2. Caution for AC Mains Lead

For your safety, please read the following text carefully.

This appliance is supplied with a moulded three-pin mains plug for your safety and convenience.

A 5-ampere fuse is fitted in this plug.

Should the fuse need to be replaced please ensure that the replacement fuse has a rating of 5 amperes and it is approved by ASTA or BSI to BS1362

Check for the ASTA mark or the BSI mark on the body of the fuse.



If the plug contains a removable fuse cover you must ensure that it is refitted when the fuse is replaced.

If you lose the fuse cover, the plug must not be used until a replacement cover is obtained.

A replacement fuse cover can be purchased from your local Panasonic Dealer.

If the fitted moulded plug is unsuitable for the socket outlet in your home then the fuse should be removed and the plug cut off and disposed of safely.

There is a danger of severe electrical shock if the cut off plug is inserted into any 13-ampere socket.

If a new plug is to be fitted please observe the wiring code as shown below.

If in any doubt, please consult a qualified electrician.

### 2.3.2.1. Important

The wires in this mains lead are coloured in accordance with the following code:

Blue	Neutral
Brown	Live

As the colours of the wires in the mains lead of this appliance may not correspond with the coloured markings identifying the terminals in your plug, proceed as follows:

The wire which is coloured BLUE must be connected to the terminal in the plug which is marked with the letter N or coloured BLACK.

The wire which is coloured BROWN must be connected to the terminal in the plug which is marked with the letter L or coloured RED.

Under no circumstances should either of these wires be connected to the earth terminal of the three pin plug, marked with the letter E or the Earth Symbol.

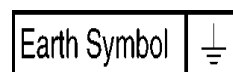

### 2.3.2.2. Before Use

Remove the Connector Cover as follows.

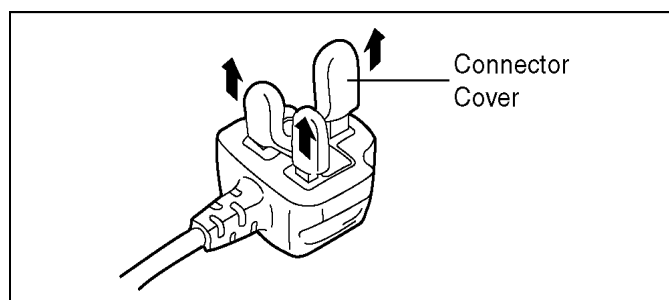

### 2.3.2.3. How to Replace the Fuse

1. Remove the Fuse Cover with a screwdriver.

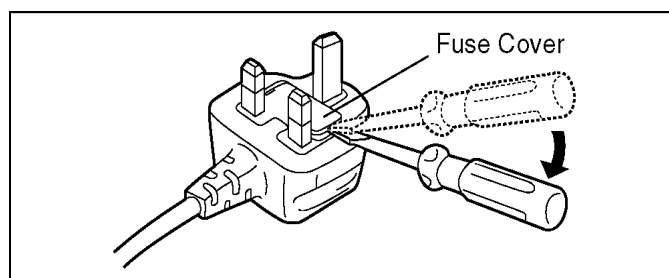

2. Replace the fuse and attach the Fuse cover.

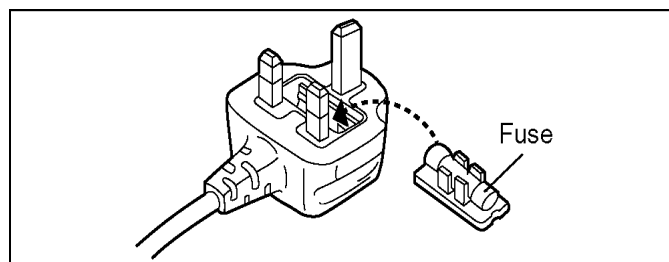

## 2.4. How to Replace the Lithium Battery

### 2.4.1. Replacement Procedure

1. Remove the FLASH TOP P.C.B.. (Refer to Disassembly Procedures.)
2. Unsolder the each soldering point of electric lead terminal for Lithium battery (Ref. No. "B8001" at foil side of FLASH TOP P.C.B.) and remove the Lithium battery together with electric lead terminal. Then replace it into new one.

**NOTE:**

The Type No. ML421 includes electric lead terminals.

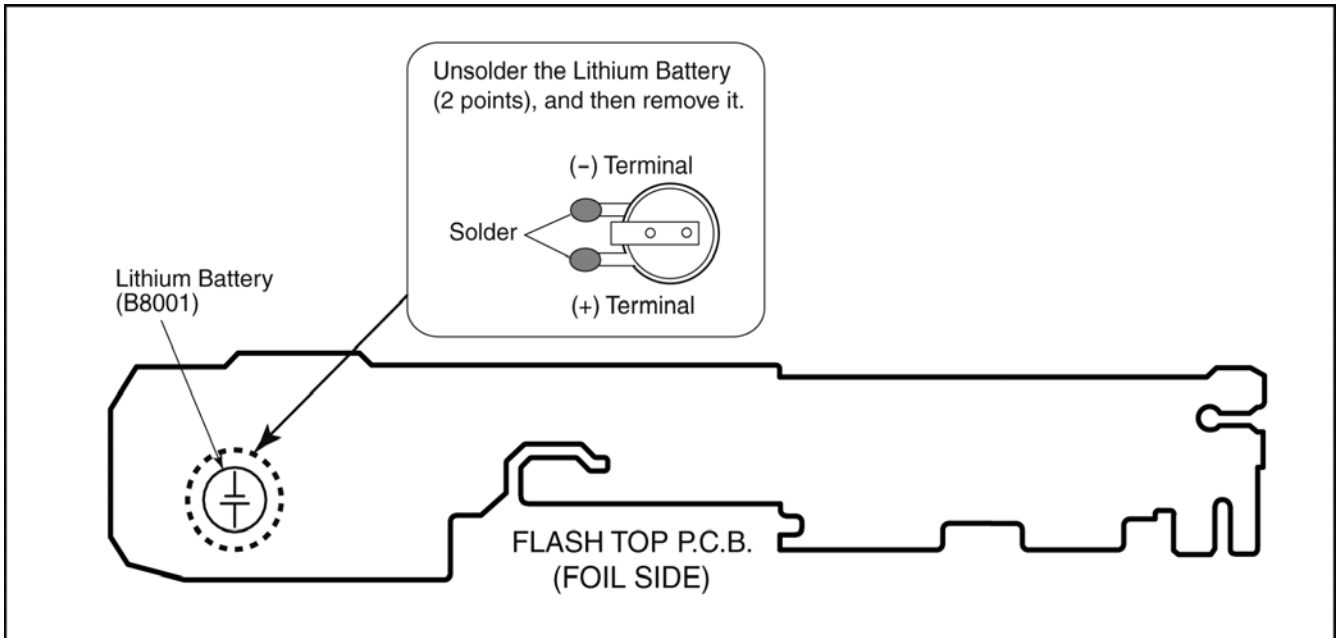

**NOTE:**

This Lithium battery is a critical component.

(Type No.: ML421 **Manufactured by Energy Company, Panasonic Corporation.**)

It must never be subjected to excessive heat or discharge.

It must therefore only be fitted in requirement designed specifically for its use.

Replacement batteries must be of same type and manufacture.

They must be fitted in the same manner and location as the original battery, with the correct polarity contacts observed.

Do not attempt to re-charge the old battery or re-use it for any other purpose.

It should be disposed of in waste products destined for burial rather than incineration.

**(For English)**

### **CAUTION**

Danger of explosion if battery is incorrectly replaced.

Replace only with the same or equivalent type recommended by the manufacturer.

Dispose of used batteries according to the manufacturer's instructions.

**(For German)**

### **ACHTUNG**

Explosionsgefahr bei falschem Anbringen der Batterie. Ersetzen Sie nur mit einem äquivalentem vom Hersteller empfohlenem Typ.

Behandeln Sie gebrauchte Batterien nach den Anweisungen des Herstellers.

**(For French)**

### **MISE EN GARDE**

Une batterie de remplacement inappropriée peut exploser. Ne remplacez qu'avec une batterie identique ou d'un type recommandé par le fabricant. L'élimination des batteries usées doit être faite conformément aux instructions du fabricant.

**NOTE:**

Above caution is applicable for a battery pack which is for DMC-FS30, FH20 series, as well.

## 3 Service Navigation

### 3.1. Introduction

This service manual contains technical information, which allow service personnel's to understand and service this model.

Please place orders using the parts list and not the drawing reference numbers.

If the circuit is changed or modified, the information will be followed by service manual to be controlled with original service manual.

### 3.2. General Description About Lead Free Solder (PbF)

The lead free solder has been used in the mounting process of all electrical components on the printed circuit boards used for this equipment in considering the globally environmental conservation.

The normal solder is the alloy of tin (Sn) and lead (Pb). On the other hand, the lead free solder is the alloy mainly consists of tin (Sn), silver (Ag) and Copper (Cu), and the melting point of the lead free solder is higher approx.30°C (86°F) more than that of the normal solder.

#### Distinction of P.C.B. Lead Free Solder being used

The letter of "PbF" is printed either foil side or components side on the P.C.B. using the lead free solder.(See right figure)
--

PbF
-----

#### Service caution for repair work using Lead Free Solder (PbF)

- The lead free solder has to be used when repairing the equipment for which the lead free solder is used.  
(Definition: The letter of "PbF" is printed on the P.C.B. using the lead free solder.)
- To put lead free solder, it should be well molten and mixed with the original lead free solder.
- Remove the remaining lead free solder on the P.C.B. cleanly for soldering of the new IC.
- Since the melting point of the lead free solder is higher than that of the normal lead solder, it takes the longer time to melt the lead free solder.
- Use the soldering iron (more than 70W) equipped with the temperature control after setting the temperature at 350±30°C (662±86°F).

#### Recommended Lead Free Solder (Service Parts Route.)

- The following 3 types of lead free solder are available through the service parts route.
  - RFKZ03D01KS-----(0.3mm 100g Reel)
  - RFKZ06D01KS-----(0.6mm 100g Reel)
  - RFKZ10D01KS-----(1.0mm 100g Reel)

#### Note

\* Ingredient: tin (Sn) 96.5%, silver (Ag) 3.0%, Copper (Cu) 0.5%, Cobalt (Co) / Germanium (Ge) 0.1 to 0.3%

### 3.3. Important Notice 1:(Other than U.S.A. and Canadian Market)

1. The service manual does not contain the following information because of issues servicing to component level without necessary equipment/facilities.
  - a. Schematic diagram, Block Diagram and P.C.B. layout of MAIN P.C.B. and SUB OPERATION P.C.B..
  - b. Parts list for individual parts for MAIN P.C.B. and SUB OPERATION P.C.B..When a part replacement is required for repairing MAIN P.C.B. and/or SUB OPERATION P.C.B., replace as an assembled parts. (MAIN P.C.B. / SUB OPERATION P.C.B.)
2. The following category is/are recycle module part. please send it/them to Central Repair Center.
  - MAIN P.C.B. (VEP56098A)
  - SUB OPERATION P.C.B. (VEP59075A)



### 3.4. How to Define the Model Suffix (NTSC or PAL model)







There are seven kinds of DMC-FS30/FH20, regardless of the colours.

- a) DMC-FH20P/PC
- b) DMC-FS30EB/EF/EG/EP
- c) DMC-FS30EE
- d) DMC-FH20GT
- e) DMC-FH20GD
- f) DMC-FH20GN
- g) DMC-FH20PU/PR/GC/GF

What is the difference is that the "INITIAL SETTINGS" data which is stored in Flash-ROM mounted on MAIN P.C.B..

#### 3.4.1. Defining methods:

To define the model suffix to be serviced, refer to the nameplate which is putted on the bottom side of the Unit.

<p><b>a) DMC-FH20P/PC</b> The nameplate for these models show the following Safety registration mark.</p> 
<p><b>b) DMC-FS30EB/EF/EG/EP</b> The nameplate for these models show the following Safety registration mark.</p> 
<p><b>c) DMC-FS30EE</b> The nameplate for this model show the following Safety registration mark.</p> 
<p><b>d) DMC-FH20GT</b> The nameplate for this model show the following Safety registration mark.</p> 
<p><b>e) DMC-FH20GD</b> The nameplate for this model show the following Safety registration mark.</p> 
<p><b>f) DMC-FH20GN</b> The nameplate for this model show the following Safety registration mark.</p> 
<p><b>g) DMC-FH20PU/PR/GC/GF</b> The nameplate for these models do not show any above Safety registration mark.</p>

**NOTE:**

After replacing the MAIN P.C.B., be sure to achieve adjustment.

The adjustment instruction is available at "software download" on the "Support Information from NWBG/VDBG-AVC" web-site in "TSN system", together with Maintenance software.

### 3.4.2. INITIAL SETTINGS:

After replacing the MAIN P.C.B., be sure to perform the initial settings after achieving the adjustment by ordering the following procedure in accordance with model suffix of the unit.

#### 1. IMPORTANT NOTICE:

Before proceeding Initial settings, be sure to read the following CAUTIONS.

#### CAUTION 1:(INITIAL SETTINGS)

---AFTER REPLACING THE MAIN P.C.B. ---

\*.The model suffix can be chosen **JUST ONE TIME**.

(Model suffix : "P/EG/EP/PU/GD/GC/GT/EF/EB/EE/GN/PC/PR and GF")

\*.Once one of the model suffix has been chosen, the model suffix lists will not be displayed, thus, it can not be changed.

[NOTE:Only for "EG, EP, EF, EB and EE" models]

\*.When one of the "EG, EP, EF, EB and EE" has been chosen, only "EG, EP, EF, EB and EE" are displayed from second times.

#### CAUTION 2:(Stored picture image data in the unit)

This unit employs "Built-in Memory" for picture image data recording.(Approx.40MB)

After proceeding "INITIAL SETTINGS", the picture image data stored in the unit is erased.

#### 2. PROCEDURES:

• Precautions: Read the above "CAUTION 1" and "CAUTION 2", carefully.

• Preparation:

1. Attach the Battery or AC Adaptor with a DC coupler to the unit.

(Since this unit has built-in memory, it can be performed without inserting SD memory card.)

2. Set the recording mode to the [ NORMAL PICTURE ] mode.

(Press the [ MODE ] button and select the [ NORMAL PICTURE ] by pressing the "[ UP ] and [ DOWN ] of Cursor buttons", then press the [ MENU/SET ] button.)

#### NOTE:

If the unit is other than [ NORMAL PICTURE ] mode, it does not display the initial settings menu.

• **Step 1. The temporary cancellation of "INITIAL SETTINGS":**

Set the [ REC ]/[ PLAYBACK ] selector switch to "[ REC ] (Camera mark)".

While keep pressing "[ UP ] of Cursor button" and [ i A ] button simultaneously, turn the Power on.

• **Step 2. The cancellation of "INITIAL SETTINGS":**

Set the [ REC ]/[ PLAYBACK ] selector switch to "[ PLAYBACK ]".

Press "[ UP ] of Cursor button" and [ i A ] button simultaneously, then turn the Power off.

• **Step 3. Turn the Power on:**

Set the [ REC ]/[ PLAYBACK ] selector switch to "[ REC ] (Camera mark)", and then turn the Power on.

• **Step 4. Display the INITIAL SETTING:**

While keep pressing [ MENU/SET ] and "[ RIGHT ] of Cursor buttons" simultaneously, turn the Power off.

The "INITIAL SETTINGS" menu is displayed.

There are two kinds of "INITIAL SETTINGS" menu form as follows:

[CASE 1. After replacing MAIN P.C.B.]

When MAIN P.C.B. has just been replaced, all of the model suffix is displayed as follows. (Five pages in total)

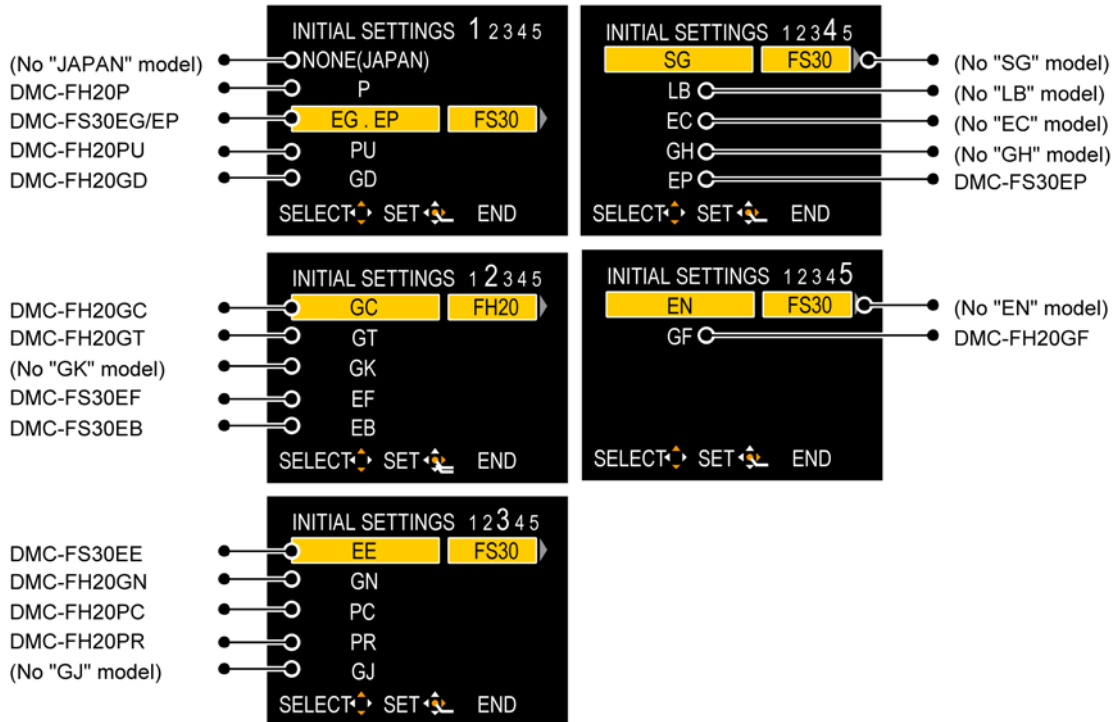

[CASE 2. Other than "After replacing MAIN P.C.B."]



• **Step 5. Choose the model suffix in "INITIAL SETTINGS": (Refer to "CAUTION 1")**

**[Caution: After replacing MAIN P.C.B.]**

The model suffix can be chosen, **JUST ONE TIME**.

Once one of the model suffix have been chosen, the model suffix lists will not be displayed, thus, it can not be changed.

Therefore, select the area carefully.

Select the area with pressing "[ UP ] / [ DOWN ] of Cursor buttons".

• **Step 6. Set the model suffix in "INITIAL SETTINGS":**

• Press the "[ RIGHT ] of Cursor buttons".

• The only set area is displayed, and then press the "[ RIGHT ] of Cursor buttons" after confirmation.

(The unit is powered off automatically.)

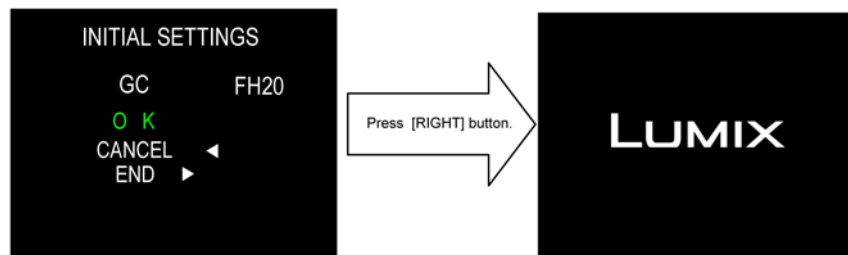

• **Step 7. CONFIRMATION:**

Confirm the display of "PLEASE SET THE CLOCK" in concerned language when the unit is turned on again.  
When the unit is connected to PC with USB cable, it is detected as removable media.

1) As for your reference, major default setting condition is as shown in the following table.

• **Default setting (After "INITIAL SETTINGS")**

	MODEL	VIDEO OUTPUT	LANGUAGE	DATE	REMARKS
a)	DMC-FH20P	NTSC	English	Month/Date/Year	
b)	DMC-FS30EG	PAL	English	Date/Month/Year	
c)	DMC-FS30EP	PAL	English	Date/Month/Year	
d)	DMC-FH20PU	NTSC	English	Month/Date/Year	
e)	DMC-FH20GD	NTSC	Korean	Year/Month/Date	
f)	DMC-FH20GC	PAL	English	Date/Month/Year	
g)	DMC-FH20GT	NTSC	Chinese (traditional)	Year/Month/Date	
h)	DMC-FS30EF	PAL	French	Date/Month/Year	
i)	DMC-FS30EB	PAL	English	Date/Month/Year	
j)	DMC-FS30EE	PAL	Russian	Date/Month/Year	
k)	DMC-FH20GN	PAL	English	Date/Month/Year	
l)	DMC-FH20PC	NTSC	English	Month/Date/Year	
m)	DMC-FH20PR	PAL	English	Date/Month/Year	
n)	DMC-FH20GF	PAL	English	Date/Month/Year	

# 4 Specifications

**Digital Camera:** Information for your safety

<b>Power Source:</b>	DC 5.1 V
<b>Power Consumption:</b>	1.1 W (When recording) 0.6 W (When playing back)

<b>Camera effective pixels:</b>	14,100,000 pixels
<b>Image sensor:</b>	1/2.33" CCD, total pixel number 14,500,000 pixels, Primary color filter
<b>Lens:</b>	Optical 8×zoom, f=5 mm to 40 mm (35 mm film camera equivalent: 28 mm to 224 mm)/F3.3 to F5.9
<b>Digital zoom:</b>	Max. 4×
<b>Extended optical zoom:</b>	Max. 16.9×
<b>Focus range:</b>	Normal: 50 cm (1.64 feet) (Wide)/2 m (6.56 feet) (Tele) to ∞ Macro/Intelligent auto: 5 cm (0.17 feet) (Wide)/1 m (3.28 feet) (Tele) to ∞ Scene Mode: There may be differences in the above settings.
<b>Shutter system:</b>	Electronic shutter+Mechanical shutter
<b>Burst recording</b>	
<b>Burst speed:</b>	Approx. 1.5 pictures/second
<b>Number of recordable pictures:</b>	Depends on the remaining capacity of the built-in memory/ card.
<b>Hi-speed burst</b>	
<b>Burst speed:</b>	Approx. 4.6 pictures/second [3M (4:3), 2.5M (3:2) or 2M (16:9) is selected as the picture size.]
<b>Number of recordable pictures:</b>	When using the built-in memory: Approx. 15 pictures (immediately after formatting) When using a Card: Max. 100 pictures (differs depending on the type of Card and the recording conditions)
<b>Shutter speed:</b>	8 seconds to 1/1600th of a second [STARRY SKY] Mode: 15 seconds, 30 seconds, 60 seconds
<b>Exposure (AE):</b>	Program AE Exposure compensation (1/3 EV Step, -2 EV to +2 EV)
<b>Metering mode:</b>	Multiple
<b>LCD monitor:</b>	2.7" TFT LCD (Approx. 230,000 dots) (field of view ratio about 100%)

<b>Flash:</b>	Flash range: <b>[ISO]</b> Approx. 60 cm (1.97 feet) to 5.8 m (19.0 feet) (Wide)
<b>Microphone:</b>	Monaural
<b>Speaker:</b>	Monaural
<b>Recording media:</b>	Built-in Memory (Approx. 40 MB)/SD Memory Card/SDHC Memory Card/SDXC Memory Card
<b>Recording file format</b>	
<b>Still Picture:</b>	JPEG (based on "Design rule for Camera File system", based on "Exif 2.21" standard)/DPOF corresponding "QuickTime Motion JPEG" (motion pictures with audio)
<b>Motion pictures:</b>	"QuickTime Motion JPEG" (motion pictures with audio)
<b>Interface</b>	
<b>Digital:</b>	"USB 2.0" (Full Speed)
<b>Analog video/audio:</b>	NTSC/PAL composite (switched by menu), Audio line output (monaural)
<b>Terminal</b>	
<b>[AV OUT/DIGITAL]:</b>	Dedicated jack (8 pin)
<b>Dimensions:</b>	Approx. 100.0 mm (W)×56.5 mm (H)×27.8 mm (D) [3.9"(W)×2.3"(H)×1.1"(D)] (excluding the projecting parts)
<b>Mass (Weight):</b>	Approx. 160 g/0.35 lb (with card and battery) Approx. 138 g/0.30lb (excluding card and battery)
<b>Operating temperature:</b>	0 °C to 40 °C (32 °F to 104 °F)
<b>Operating humidity:</b>	10% to 80%

**Battery Charger:** Information for your safety

<b>Input:</b>	110 V to 240 V ~ 50/60 Hz, 0.2 A
<b>Output:</b>	4.2 V = 0.65 A (Battery charging)

**Equipment mobility:** Movable

**Battery Pack (lithium-ion):** Information for your safety

<b>Voltage/capacity:</b>	3.6 V/740 mAh
--------------------------	---------------

**NOTE:(Only for "EB/EF/EG/EP/PR" models)**

- Data from the PC can not be written to the camera using the USB connection cable.
- Motion pictures can be recorded continuously for up to 15 minutes.  
The maximum continuous recording time (up to 15 minutes) is displayed on the screen.

# 5 Location of Controls and Components

## Names of the Components

- 1 Flash
- 2 Lens
- 3 Self-timer indicator  
AF assist lamp

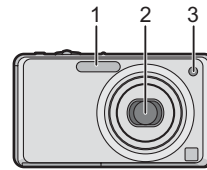

- 4 LCD monitor
- 5 [MENU/SET] button
- 6 [DISPLAY] button
- 7 [Q.MENU]/Delete button
- 8 [MODE] button
- 9 [REC]/[PLAYBACK] selector switch

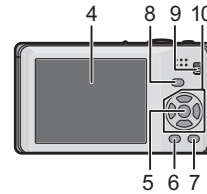

- 10 Cursor buttons
  - (A): ▲/Exposure compensation
  - (B): ▼/Macro Mode
  - (C): ◀/Self-timer button
  - (D): ▶/Flash setting button

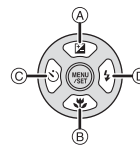

- 11 Camera ON/OFF switch
- 12 Zoom lever
- 13 Speaker
- 14 Microphone
- 15 Shutter button
- 16 Intelligent auto button

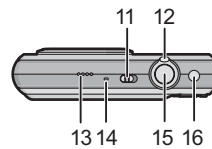

- 17 Hand strap eyelet
  - Be sure to attach the hand strap when using the camera to ensure that you will not drop it.
- 18 Lens barrel
- 19 [AV OUT/DIGITAL] socket

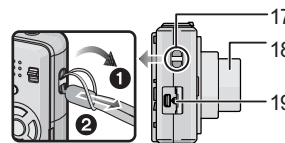

- 20 Tripod receptacle
  - When you use a tripod, make sure the tripod is stable when the camera is attached to it.
- 21 Card/Battery door
- 22 Release lever

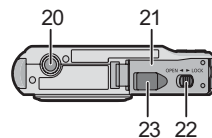

- 23 DC coupler cover
  - When using an AC adaptor, ensure that the Panasonic DC coupler and AC adaptor are used.
  - We recommend you use a battery with sufficient battery power or the AC adaptor when recording motion pictures.
  - If while recording motion pictures using the AC adaptor and the power supply is cut off due to a power outage or if the AC adaptor is disconnected etc., the motion picture being recorded will not be recorded.

## Selecting the [REC] Mode

### Intelligent Auto Mode

The subjects are recorded using settings automatically selected by the camera.

#### ■ To select a [REC] modes from the [REC] modes list

- 1 Turn the camera on.**
  - [MENU/SET] button
  - [REC]/[PLAYBACK] selector switch
  - [MODE] button
- 2 Slide the [REC]/[PLAYBACK] selector switch to .**
- 3 Press [MODE].**
- 4 Press  $\blacktriangle/\blacktriangledown$  to select the mode.**
- 5 Press [MENU/SET].**

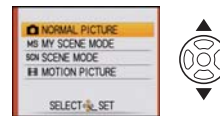
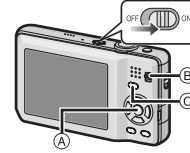

#### ■ List of [REC] Modes

### Normal Picture Mode

The subjects are recorded using your own settings.

### **MS** My Scene Mode

Pictures are taken using previously registered recording scenes.

### **SCN** Scene Mode

This allows you to take pictures that match the scene being recorded.

### Motion Picture Mode

This mode allows you to record motion pictures with audio.

## About the Battery

- The camera has a function for distinguishing batteries which can be used safely. The dedicated battery supports this function. The only batteries suitable for use with this unit are genuine Panasonic products and batteries manufactured by other companies and certified by Panasonic. (Batteries which do not support this function cannot be used). Panasonic cannot in any way guarantee the quality, performance or safety of batteries which have been manufactured by other companies and are not genuine Panasonic products.

It has been found that counterfeit battery packs which look very similar to the genuine product are made available to purchase in some markets. Some of these battery packs are not adequately protected with internal protection to meet the requirements of appropriate safety standards. There is a possibility that these battery packs may lead to fire or explosion. Please be advised that we are not liable for any accident or failure occurring as a result of use of a counterfeit battery pack. To ensure that safe products are used we would recommend that a genuine Panasonic battery pack is used.

# 6 Service Mode

## 6.1. Error Code Memory Function

### 1. General description

This unit is equipped with history of error code memory function, and can be memorized 16 error codes in sequence from the latest. When the error is occurred more than 16, the oldest error is overwritten in sequence.

The error code is not memorized when the power supply is shut down forcibly (i.e., when the unit is powered on by the battery, the battery is pulled out) The error code is memorized to FLASH-ROM when the unit has just before powered off.

### 2. How to display

The error code can be displayed by ordering the following procedure:

#### • Preparation:

1. Attach the Battery or AC Adaptor with a DC coupler to the unit.

#### NOTE:

\*Since this unit has built-in memory, it can be performed without inserting SD memory card.

\*It is not a matter or the setting condition of Recording mode (such as "normal picture/scene/motion picture" mode) to display the error code.

#### • Step 1. The temporary cancellation of "INITIAL SETTINGS":

Set the [ REC ]/[ PLAYBACK ] selector switch to "[ REC ] (Camera mark)".

While keep pressing "[ UP ] of Cursor button" and [ iA ] button simultaneously, turn the Power on.

#### • Step 2. Execute the error code display mode:

Press the "[ LEFT ] of Cursor button", [ MENU/SET ] button and [ iA ] button simultaneously.

The display is changed as shown below when the above buttons are pressed simultaneously.

Normal display → Error code display → Operation history display → Normal display → .....

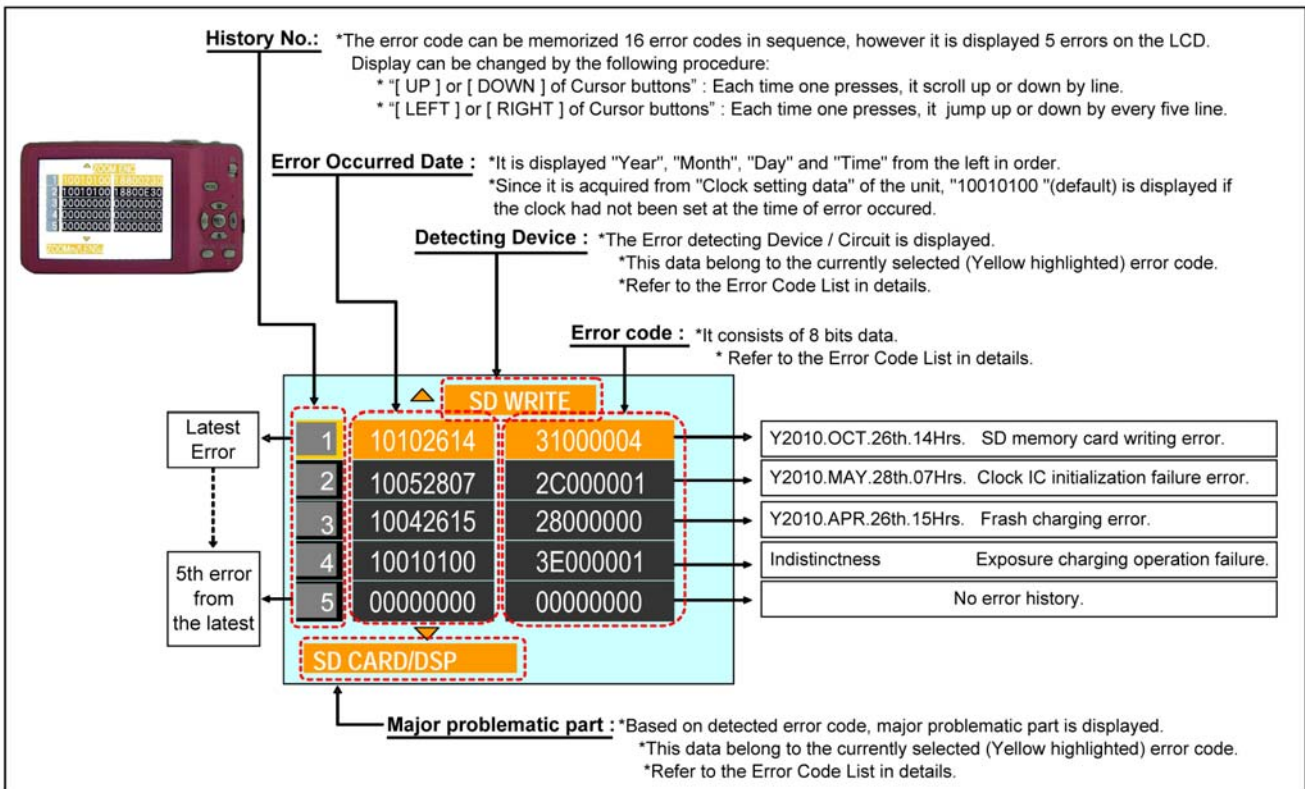

Example of Error Code Display



• 3. Error Code List

The error code consists of 8 bits data and it shows the following information.

Attribute	Main item	Sub item	Error code		Contents (Upper line)		Error Indication					
			High 4 bits	Low 4 bits	Problematic Part & Check point (Lower line)		Detecting device	Problematic Part/Circuit				
LENS	Lens drive	OIS	18*0	1000	PSD (X) error. Hall element (X axis) position detect error in OIS unit.	OIS Unit	OIS X	LENSu NG				
				2000	PSD (Y) error. Hall element (Y axis) position detect error in OIS unit.	OIS Unit	OIS Y					
			3000	GYRO (X) error. Gyro (IC7101: X axis) detect error on Sub Operation P.C.B., IC7101 (Gyro element) or IC6001 (VENUS 4)	GYRO X	GYRO NG						
				4000	GYRO (Y) error. Gyro (IC7101: Y axis) detect error on Sub Operation P.C.B., IC7101 (Gyro element) or IC6001 (VENUS 4)		GYRO Y					
			5000	MREF error (Reference voltage error).	OIS REF	LENSSd/DSP NG						
				6000	IC9101 (SYSTEM) or IC6001 (VENUS 4)		OISX REF					
			7000	Drive voltage (X) error.	OISX REF	LENSu/LENS FPC						
		7000		LENS Unit, LENS flex breaks, IC6001 (VENUS 4) AD value error, etc.	OISY REF							
		Zoom	Zoom	0710	Collapsible barrel Low detect error	(Collapsible barrel encoder always detects Low.)	Mechanical lock, FP9002-(2) signal line or IC6001 (VENUS 4)	ZOOM L	ZOOMm/LENSu			
					0720	Collapsible barrel High detect error	(Collapsible barrel encoder always detects High.)	Mechanical lock, FP9002-(2) signal line or IC6001 (VENUS 4)		ZOOM H		
				0730	Zoom motor sensor error.	Mechanical lock, FP9002-(32), (35) signal line or IC6001 (VENUS 4)	ZOOM ENC					
					0740	Zoom motor sensor error. (During monitor mode.)						
				0750	Zoom motor sensor error. (During monitor mode with slow speed.)	Mechanical lock, FP9002-(32), (35) signal line or IC6001 (VENUS 4)	ZOOM ENC					
					0750	Zoom motor sensor error. (During monitor mode with slow speed.)						
				0701	HP High detect error	(Focus encoder always detects High, and not becomes Low)	LENS FPC/DSP					
					0702	HP Low detect error		(Focus encoder always detects Low, and not becomes High)				
				Lens	Lens	18*1	0000	Power ON time out error.		LENS drive system	LENS DRV	LENSu
							18*2	0000		Power OFF time out error.		
	Adj. History	OIS	19*0	2000	OIS adj. Yaw direction amplitude error (small)	OIS ADJ	OIS ADJ					
				3000	OIS adj. Pitch direction amplitude error (small)							
				4000	OIS adj. Yaw direction amplitude error (large)							
				5000	OIS adj. Pitch direction amplitude error (large)							
				6000	OIS adj. MREF error							
				7000	OIS adj. time out error							
8000				OIS adj. Yaw direction off set error								
9000				OIS adj. Pitch direction off set error								
A000				OIS adj. Yaw direction gain error								
B000				OIS adj. Pitch direction gain error								
C000				OIS adj. Yaw direction position sensor error								
D000				OIS adj. Pitch direction position sensor error								
E000				OIS adj. other error								
HARD				VENUS A/D	Flash			28*0	0000	Flash charging error.	STRB CHG	STRB PCB/FPC
	FLASH ROM (EEPROM Area)	FLASH ROM (EEPROM Area)	2B*0	0001	EEPROM read error	FROM RE	FROM					
				0002	EEPROM write error	FROM WR	FROM					
				0005	Firmware version up error	(No indication)	(No indication)					
				0008	SDRAM error	(No indication)	(No indication)					
	SYSTEM	RTC	2C*0	0001	SDRAM Mounting defective	SYS INIT	MAIN PCB					
0001				SYSTEM IC initialize failure error	SYS INIT	MAIN PCB						
SOFT	CPU	Reset	30*0	0001	NMI reset	NMI RST	MAIN PCB					
				0007	Non Mask-able Interrupt (30000001-30000007 are caused by factors)							
	Card	Card	31*0	0001	Card logic error	SD CARD	SD CARD/DSP					
				0002	SD memory card data line or IC6001 (VENUS 4)							
				0004	Card physical error							
				0004	Write error							
	CPU, ASIC hard	Stop	38*0	0001	SD memory card data line or IC6001 (VENUS 4)	INMEMORY	FROM					
				0001	Camera task finish process time out.							
				0002	Communication between Lens system and IC6001 (VENUS 4)							
				0100	Camera task invalid code error.							
				0200	IC6001 (VENUS 4)							
				0300	File time out error in recording motion image							
	Memory area	Memory area	3A*0	0008	File data cue send error in recording motion image	(No indication)	(No indication)					
				0008	IC6001 (VENUS 4)							
Operation	Power on	3B*0	0000	Single or burst recording brake time out.	INIT	(No indication)						
			0000	USB work area partitioning failure								
Zoom	Zoom	3C*0	0000	USB dynamic memory securing failure when connecting	ZOOM	ZOOMm/LENSu						
			0000	FLASHROM processing early period of camera during movement.								
			0000	Inperfect zoom lens processing								
			0000	Zoom lens								
			0000	Software error	DSP	DSP						
			0000	(0-7bit : command, 8-15bit : status)								
			0000	Though record preprocessing is necessary, it is not called.								
			0000	Though record preprocessing is necessary, it is not completed.	(No indication)	(No indication)						

## Important notice about "Error Code List"

### 1) About "\*" indication:

The third digit from the left is different as follows.

- In case of 0 (example: 18001000)

When the third digit from the left shows "0", this error occurred under the condition of INITIAL SETTINGS has been completed.

It means that this error is occurred basically at user side.

- In case of 8 (example: 18801000)

When the third digit from the left shows "8", this error occurred under the condition of INITIAL SETTINGS has been released.

(Example; Factory assembling-line before unit shipment, Service mode etc.)

It means that this error is occurred at service side.

### 2) About "?" indication: ("18\*0 0?01" to "18\*0 0?50"):

The third digit from the right shows one of the hexadecimal ("0" to "F") character.

## • 4. How to exit from Error Code display mode:

Simply, turn the power off. (Since Error code display mode is executed under the condition of temporary cancellation of "INITIAL SETTINGS", it wake up with normal condition when turn off the power.)

### NOTE:

The error code can not be initialized.

## 6.2. ICS (Indication of additional Camera Settings when picture was taken) function

### 1. General description

This unit is equipped with ICS (ICS: Indication of additional Camera Settings when picture was taken) function by playing back the concerned picture on the LCD display.

(This function is achieved by utilizing "maker note" data stored in Exif data area of recorded picture file.)

To proceed failure diagnosis, use this ICS function together with "displaying the recorded picture with picture information" function.

### NOTE:

- The ICS function operates with a picture which is only taken with the same model. (It may not be displayed when the picture was taken with other model.)
- Since Exif data is not available after the picture is edited by PC, the ICS function may not be activated.

### 2. How to display

The ICS data is displayed by ordering the following procedure:

#### • Preparation:

1. Attach the Battery or AC Adaptor with a DC coupler to the unit.

### NOTE:

It is not a matter or the setting condition of Recording mode (such as "normal picture/scene/motion picture" mode) to display the ICS data.

#### • Step 1. The temporary cancellation of "INITIAL SETTINGS":

Set the [ REC ]/[ PLAYBACK ] selector switch to "[ REC ] (Camera mark)".

While keep pressing "[ UP ] of Cursor button" and [ iA ] button simultaneously, turn the Power on.

#### • Step 2. Execute the ICS display mode:

Set the [ REC ]/[ PLAYBACK ] selector switch to [ PLAYBACK ].

Select the concerned picture by pressing the "[ LEFT ] and [ RIGHT ] of Cursor button".

Press the "[ LEFT ] of Cursor button", [ MENU/SET ] button and [ iA ] button simultaneously.

Press the [ DISPLAY ] button, 3 times.

The display condition is changed as shown below when the [ DISPLAY ] button is pressed.

Code display → Code + Picture display (1) → Code + Picture display (2) → ICS display → Code display .....

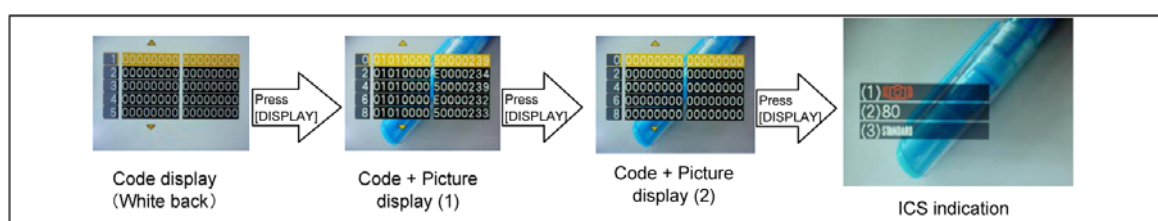

### 3. How to read

**(1). Jitter alert was displayed or not:**  
 This part shows that the "Jitter alert" mark was displayed or not when the picture has just before been taken.  
 +.With "Jitter alert" mark : The "Jitter alert" mark was displayed.  
 +.Without "Jitter alert" mark: The "Jitter alert" mark was not displayed.  
 [About "Jitter alert" mark]  
 Due to lacking the enough light amount etc, shooting condition prone to make a "hand jitter", the "Jitter alert" mark is displayed.  
 [Reference Guide]  
 (Applicable settings : Normal picture mode, ISO100, WIDE edge, Flash OFF)  
 +.The "Jitter alert" mark is displayed when the shutter speed is 1/15th and below.

**(2). ISO Sensitivity Setting condition:**  
 This part shows that the "ISO Sensitivity" setting condition when the picture had been taken.  
 (Note: The [i ISO] is displayed when the "Intelligent ISO" was selected.)  
 For instance, when the recorded picture information shows [ISO80], it can be confirmed the ISO setting condition : [AUTO], [INTELLIGENT ISO] or [ISO 80](Fixed: set by user).  
 [Point for Confirmation]  
 \*The symptom is "Picture with "hand jitter". Subject is not clearly stopped." in darker scene, does the picture was taken with lower ISO setting mode?  
 \*The symptom is "Noisy picture. Rough picture image" in brighter scene, does the picture was taken with higher ISO setting mode?

**(3). Color mode Setting condition:**  
 This part shows that the "Color mode" setting condition when the picture had been taken.  
 [Point for Confirmation]  
 \*The symptom is "Color is strange. The picture is bluish (Yellowish) ", does the picture was taken with [SEPIA] / [COOL] / [WARM] settings?  
 NOTE: As for the symptom related with the color, confirm the picture information which is displayed in normal playback screen as well.  
 (In normal playback screen, the setting condition of "White balance" and "WB Adjustment "can be confirmed.)

[Reference Guide : Settings "When taking picture"]

**<ISO SENSITIVITY>**  
 \*This allows the sensitivity to light (ISO sensitivity) to be set. Setting to a higher figure enables pictures to be taken even in dark places without the resulting pictures coming out dark.  
 \*In this unit, it can be set one of the [AUTO], [80], [100], [200], [400], [800] and [1600] in "Normal shooting" mode.  
 (The ISO sensitivity setting is not available when the [INTELLIGENT ISO] is being used.)  
 \*When setting to [AUTO], the ISO sensitivity is automatically adjusted to a maximum of [ISO400] according to the brightness.  
 (It can be adjusted to a maximum of [ISO1600] when using the flash.)  
 \*To avoid picture noise, we recommend that you either reduce the ISO sensitivity level or set [COLOR MODE] to [NATURAL], and then take pictures.

ISO sensitivity	80	↔	1600
Recording location (recommended)	When it is light (outdoors)		When it is dark
Shutter speed	Slow		Fast
Noise	Less		Increased

**<COLOR MODE>**  
 \*Using these modes, the pictures can be made sharper or softer, the colors of the pictures can be turned into sepia colors or other color effects can be achieved.  
 \*In this unit, it can be set one of the following effects in "Normal shooting" mode.

[STANDARD] : This is the standard setting.	[B/W] : The picture becomes black and white.
[NATURAL] : The picture becomes softer.	[SEPIA] : The picture becomes sepia.
[VIVID] : The picture becomes sharper.	[COOL] : The picture becomes bluish.
	[WARM] : The picture becomes reddish.

NOTE: You cannot set [NATURAL], [VIVID], [COOL] or [WARM] in Intelligent auto mode.  
 \*When you take pictures in dark places, noise may become visible. To avoid noise, we recommend setting to [NATURAL].

Normal playback screen  
 (Recorded picture with information)



\*In playback mode, the picture information is displayed when pressing the [DISPLAY] button (It can be confirmed at user as well.)  
 \*Use this indication together with ICS function

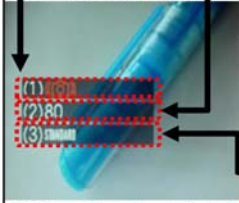

[ICS display (Sample)]

(1). Jitter alert mark : [Indicated]  
 (2). ISO sens. setting : ISO80 (Fixed)  
 (3). Color mode setting: Standard



### 4. How to exit:

Simply, turn the power off. (Since ICS function is executed under the condition of temporary cancellation of "INITIAL SETTINGS", it wake up with normal condition when turn off the power.)

# 7 Service Fixture & Tools

## 7.1. Service Fixture and Tools

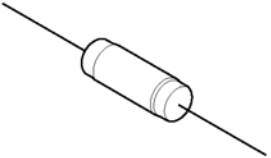
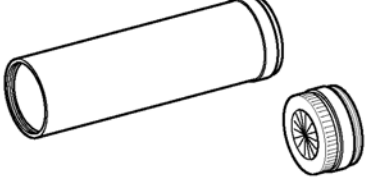
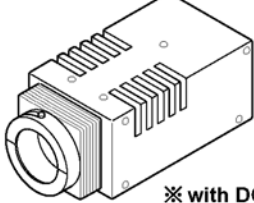
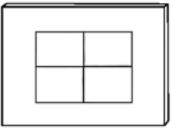
The following Service Fixture and tools are used for checking and servicing this unit.

<p><b>Resistor for Discharging</b> ERG5SJ102</p>	<p><b>Infinity Lens (with Focus Chart)</b> VFK1164TCM02</p>	<p><b>LIGHT BOX</b> VFK1164TDVLB</p>
 <p>An equivalent type of Resistor may be used.</p>	 <p>* VFK1164TCM03 can be used. * RFKZ0422 can be used.</p>	 <p>※ with DC Cable * RFKZ0523 can be used.</p>
<p><b>TR Chart</b> RFKZ0443</p>	<p><b>Lens Cleaning Kit (BK)</b> VFK1900BK</p>	<p><b>Grease (for lens)</b> RFKZ0472</p>
	 <p>* Only supplied as 10 set/box.</p>	

## 7.2. When Replacing the Main P.C.B.

After replacing the MAIN P.C.B., be sure to achieve adjustment.

The adjustment instruction is available at "software download" on the "Support Information from NDBG/VDBG-AVC" web-site in "TSN system", together with Maintenance software.

## 7.3. Service Position

This Service Position is used for checking and replacing parts. Use the following Extension cables for servicing.

Table S1 Extension Cable List

No.	Parts No.	Connection	Form
1	RFKZ0494	FP9001 (MAIN) - CCD UNIT	45PIN 0.3 FFC
2	RFKZ0416	FP9002 (MAIN) - LENS UNIT	41PIN 0.3 FFC
3	RFKZ0416	FP9003 (MAIN) - LCD UNIT	41PIN 0.3 FFC
4	RFKZ0418	PP9001 (MAIN) - PS8001 (FLASH TOP)	30PIN B to B
5	RFKZ0553	PS9001 (MAIN) - PP9501 (SUB OPERATION)	16PIN B to B

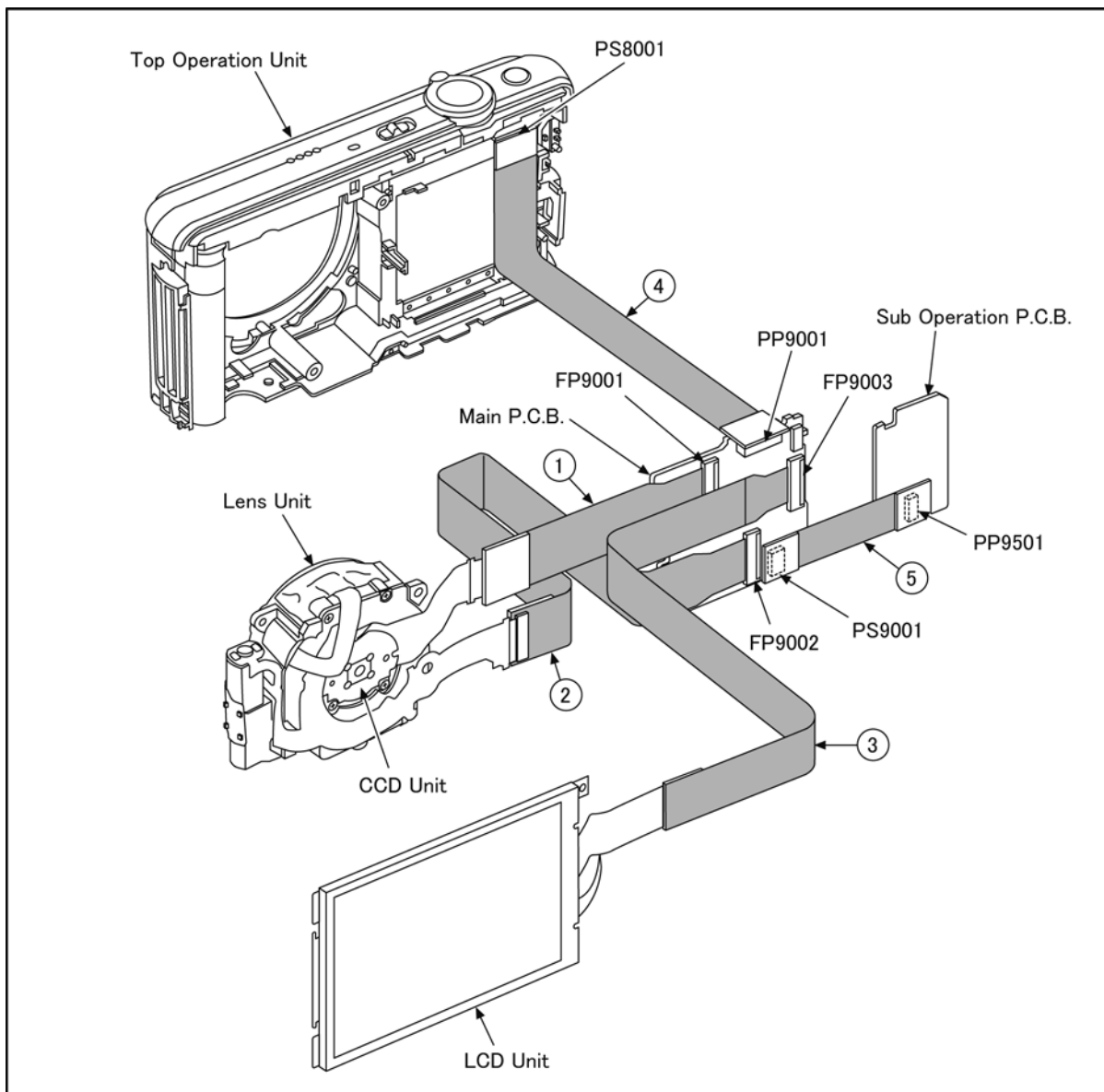

### CAUTION-1. (When servicing FLASH TOP P.C.B.)

1. Be sure to discharge the capacitor on FLASH TOP P.C.B..

Refer to "HOW TO DISCHARGE THE CAPACITOR ON FLASH TOP P.C.B.."

The capacitor voltage is not lowered soon even if the AC Cord is unplugged or the battery is removed.

2. Be careful of the high voltage circuit on FLASH TOP P.C.B..
3. DO NOT allow other parts to touch the high voltage circuit on FLASH TOP P.C.B..

# 8 Disassembly and Assembly Instructions

## 8.1. Disassembly Flow Chart

This is a disassembling chart.

When assembling, perform this chart conversely.

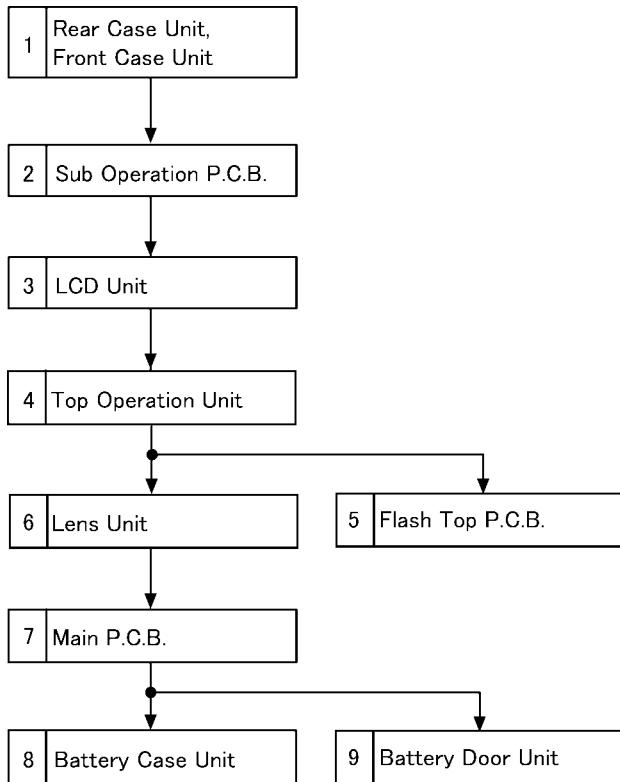

## 8.2. PCB Location

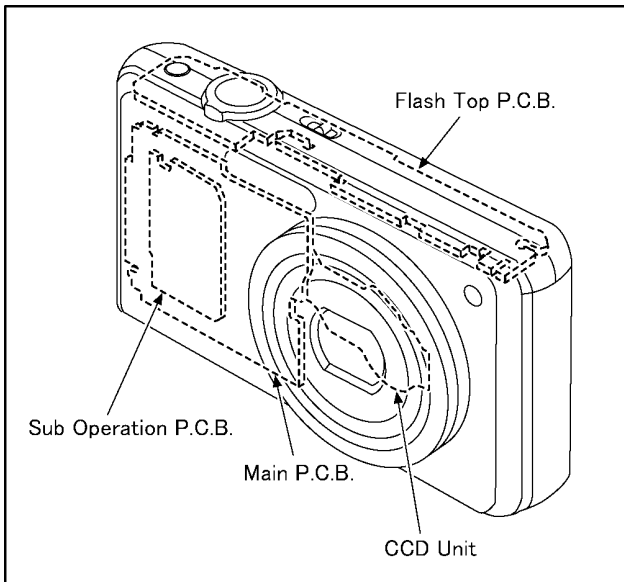



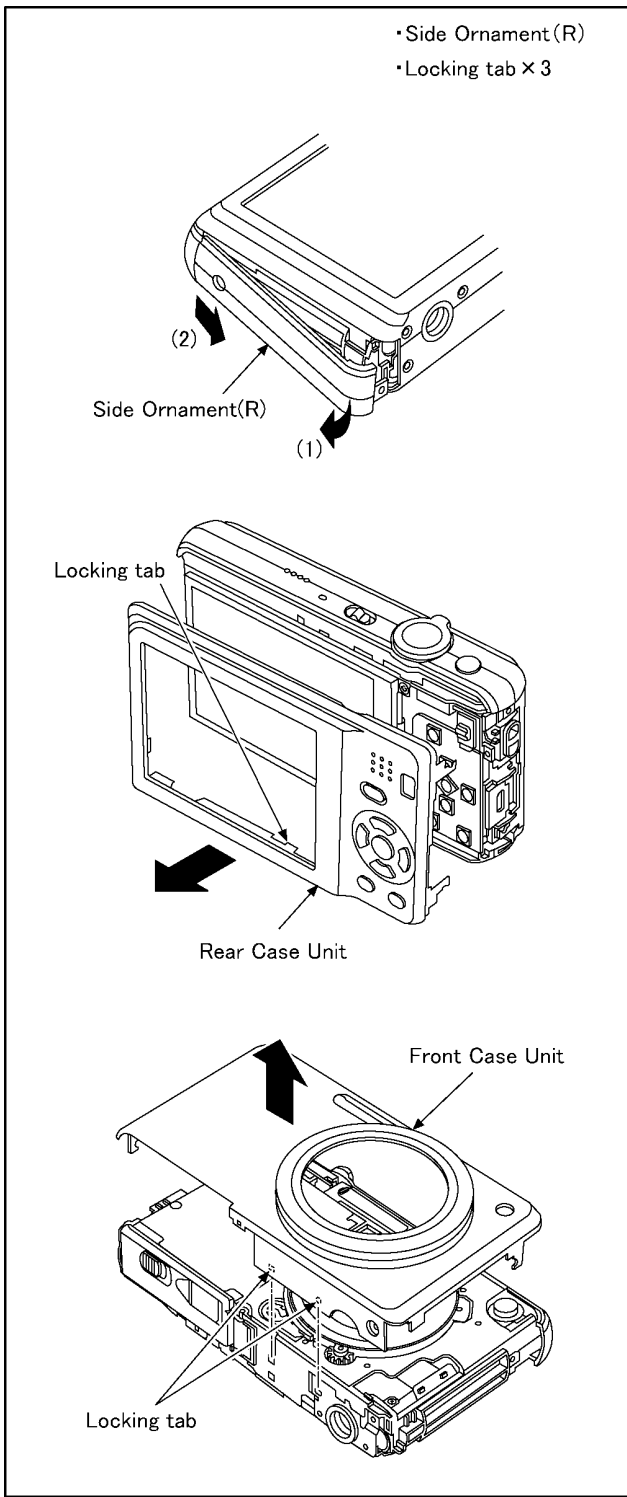

(Fig. D2)

### 8.3.2. Removal of the Sub Operation P.C.B.

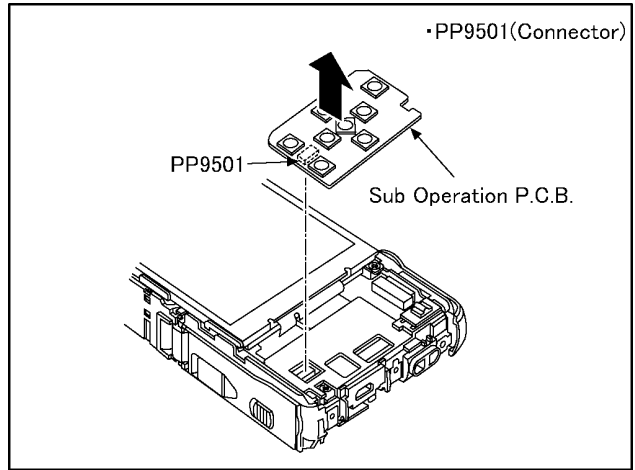

(Fig. D3)

### 8.3.3. Removal of the LCD Unit

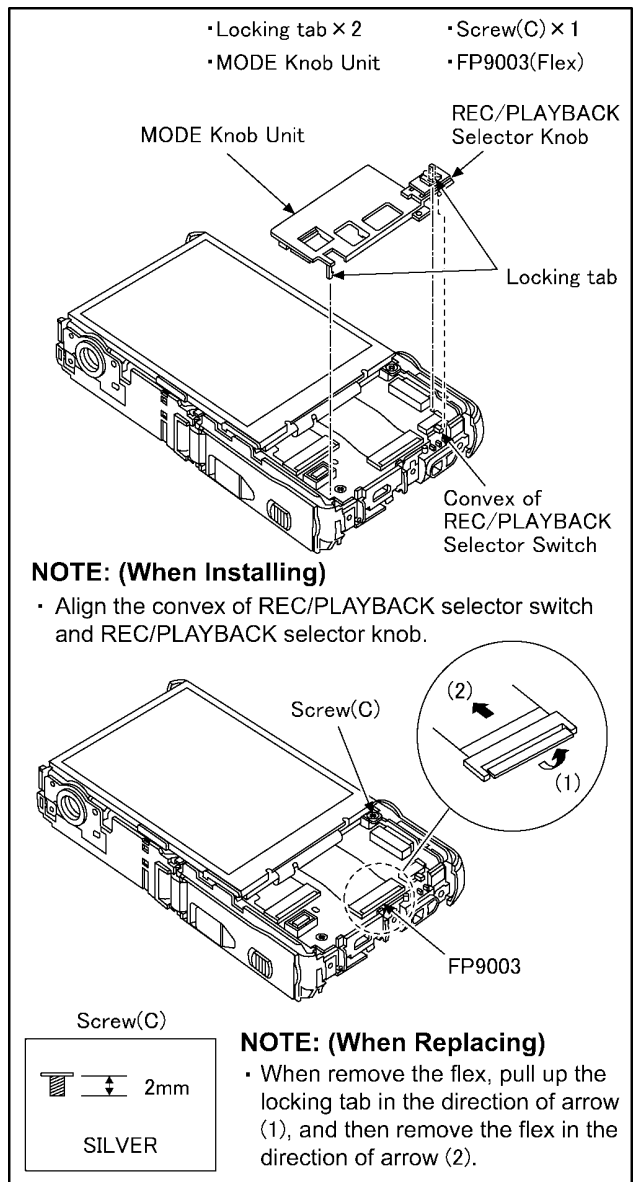

(Fig. D4)



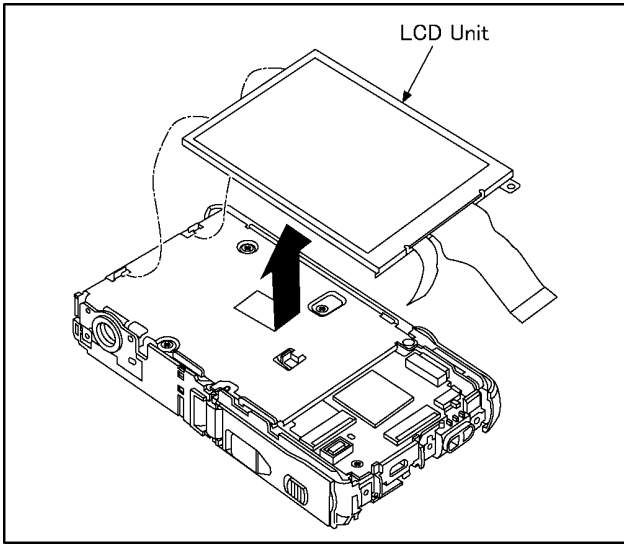

(Fig. D5)

### 8.3.4. Removal of the Top Operation Unit

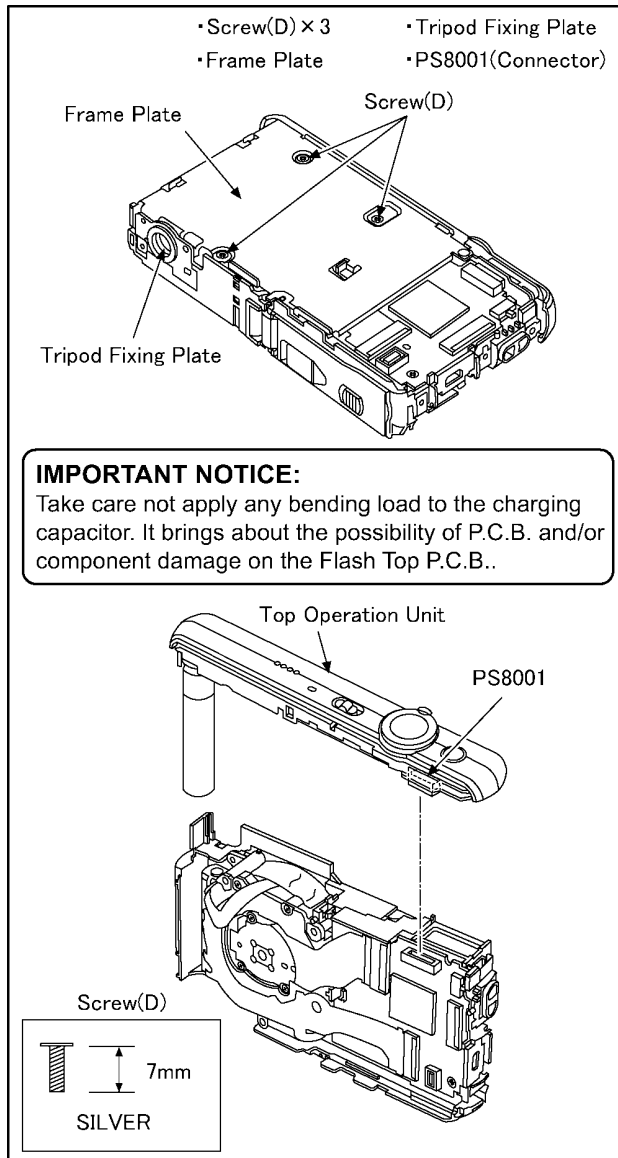

(Fig. D6)

### 8.3.5. Removal of the Flash Top P.C.B.

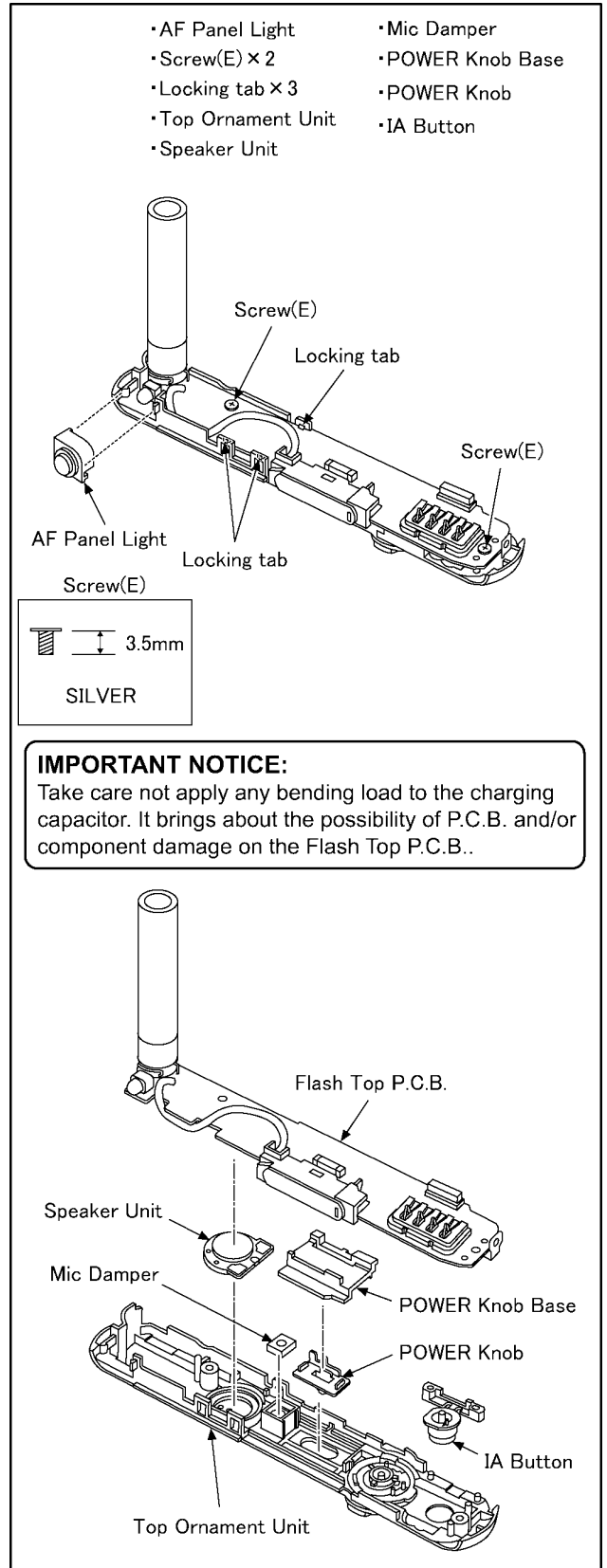

(Fig. D7)

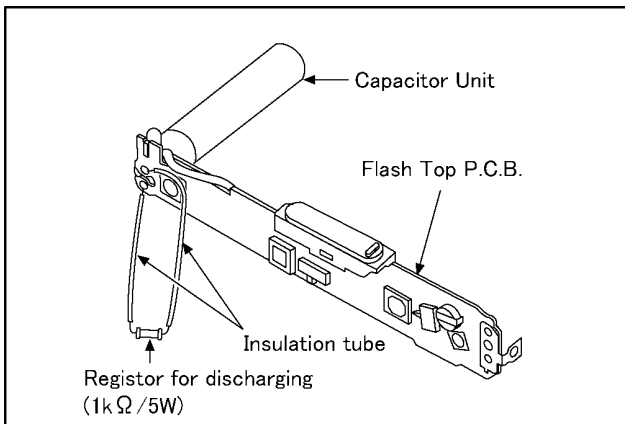

**CAUTION**

Be sure to discharge the capacitor on Flash Top P.C.B. before disassembling.

1. Remove the Flash Top P.C.B..
2. Put the insulation tube on the lead part of resistor (ERG5SJ102: 1kΩ/5W).
3. Put the resistor between both terminals of capacitor unit for approx. 5 seconds.

**NOTE: (When Installing)**

- Align the convex of power switch and power knob.

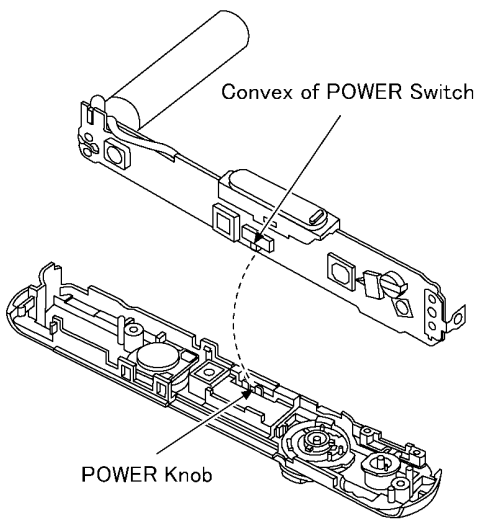

(Fig. D8)

### 8.3.6. Removal of the Lens Unit

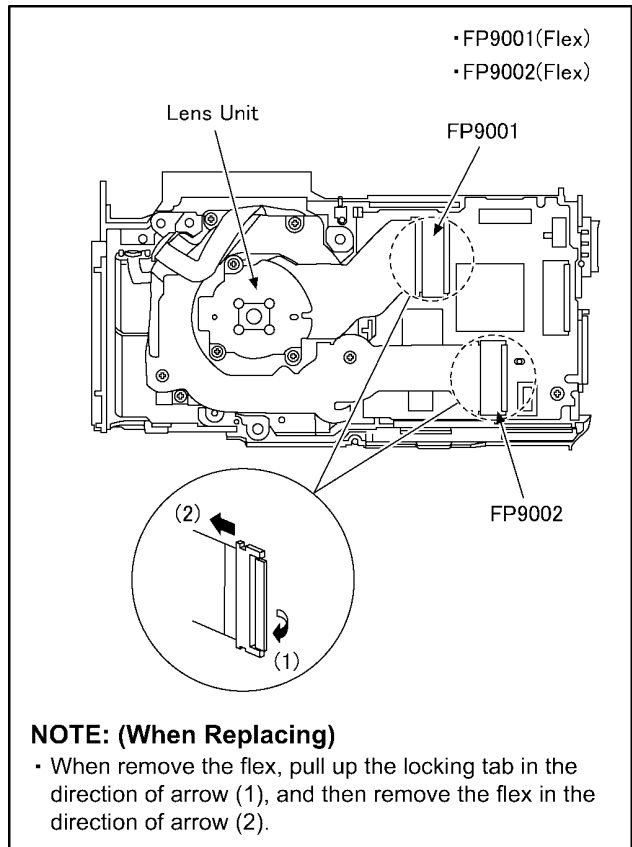

**NOTE: (When Replacing)**

- When remove the flex, pull up the locking tab in the direction of arrow (1), and then remove the flex in the direction of arrow (2).

(Fig. D9)

### 8.3.7. Removal of the Main P.C.B.

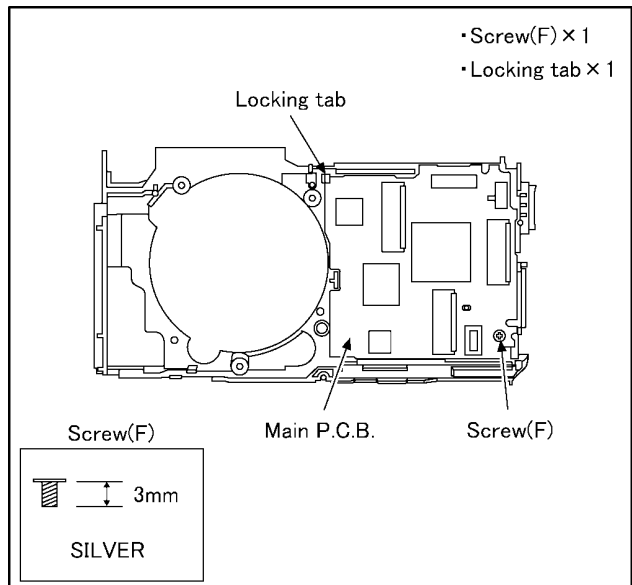

(Fig. D10)

### 8.3.8. Removal of the Battery Case Unit

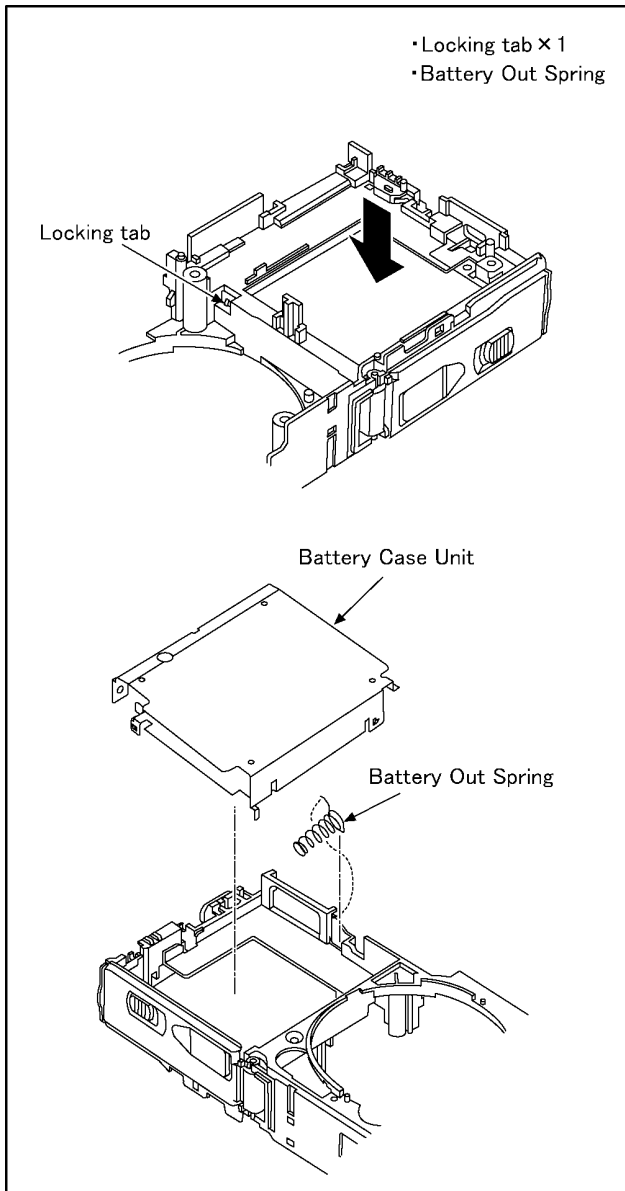

(Fig. D11)

### 8.3.9. Removal of the Battery Door Unit

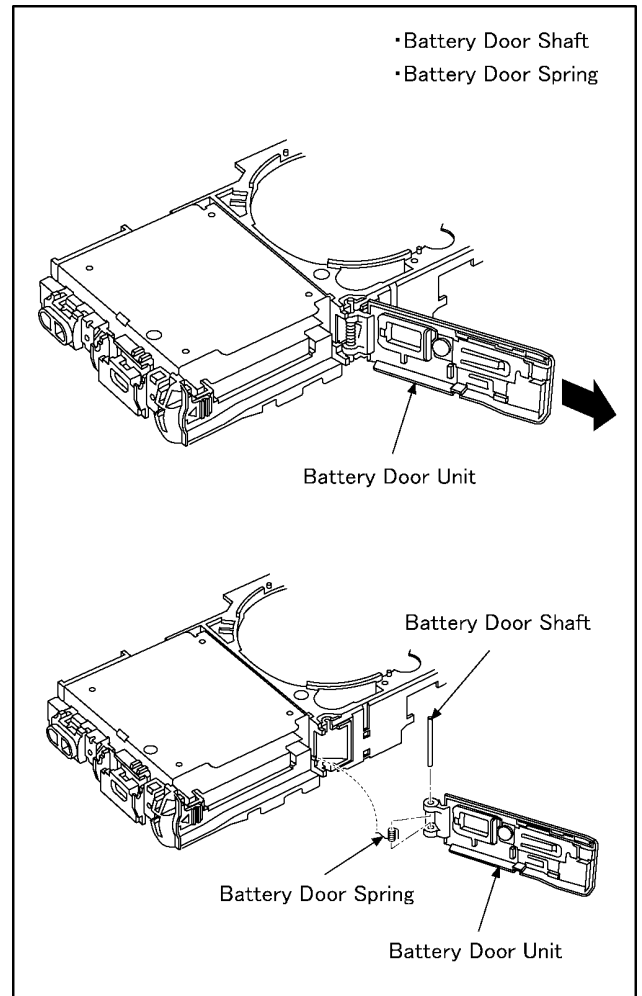

(Fig. D12)

#### NOTE: (When Assembling)

Make sure to confirm the following points when assembling:

- The Screw is tightened enough.
- Assembling conditions are fine. (No distortion, no abnormal-space.)
- No dust and/or dirt on Lens surfaces.
- LCD image is fine. (No dust and dirt on it, and no gradient images.)

## 8.4. Lens Disassembly Procedure

### Precaution:

1. Do not remove the CCD when disassembling or re-assembling the lens in order to maintain it clean.  
When remove it, refer to item "8.6."
2. Keep dust or dirt away from the lens.
3. To remove dirt or dust from the lens, blow with dry air.
4. Do not touch the lens surface.
5. Apply grease (RFKZ0472) as shown on "THE APPLICATION OF GREASE METHOD" in the figure.
6. Apply a light coat of grease using an object similar to a toothpick.
7. The drive frame unit and penetration cam frame should be replaced as a unit.

### 8.4.1. Removal of the Zoom Motor and Lens FPC Unit

1. Remove the 5 tapes.
2. Unscrew the 2 screws (A).
3. Shift the zoom motor to the direction of arrow (1).
4. Unscrew the 1 screw (B).
5. Remove the photo sensor.
6. Remove the 13 solders (A).
7. Remove the 3 solders (B).
8. Remove the 5 locks.

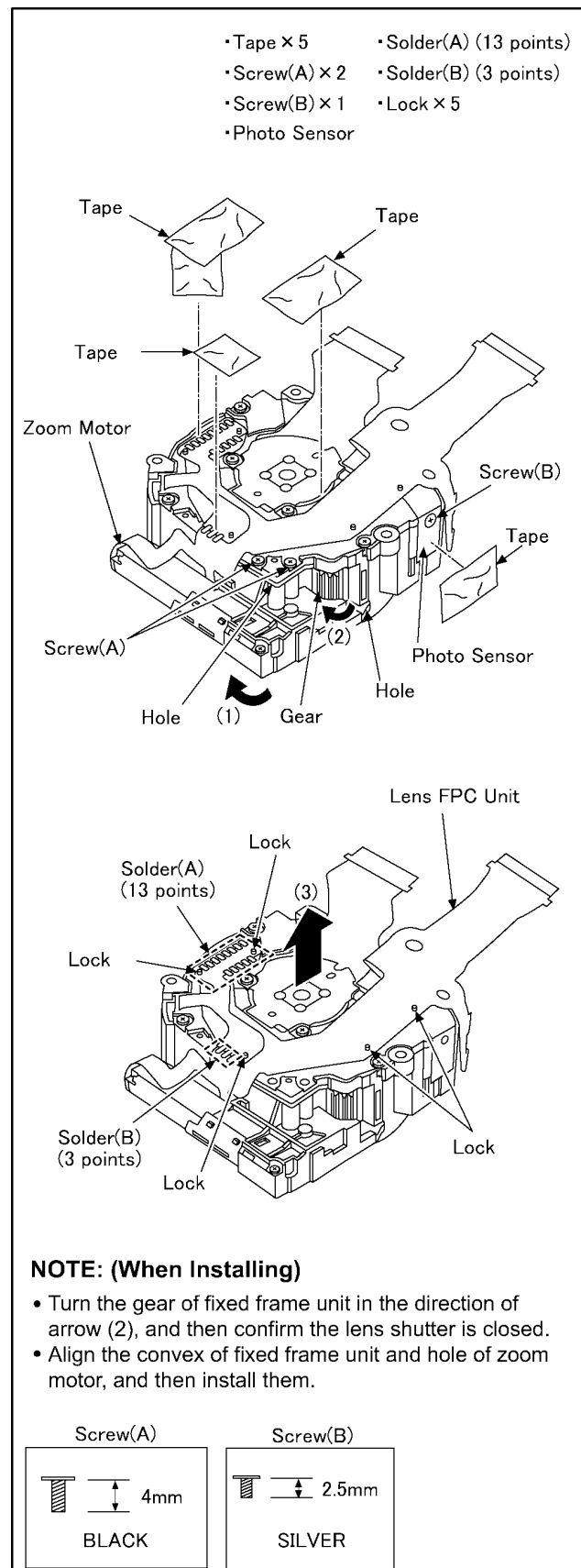

9. Remove the 4 solders (C).
10. Remove the lens FPC unit to the direction of arrow (3).

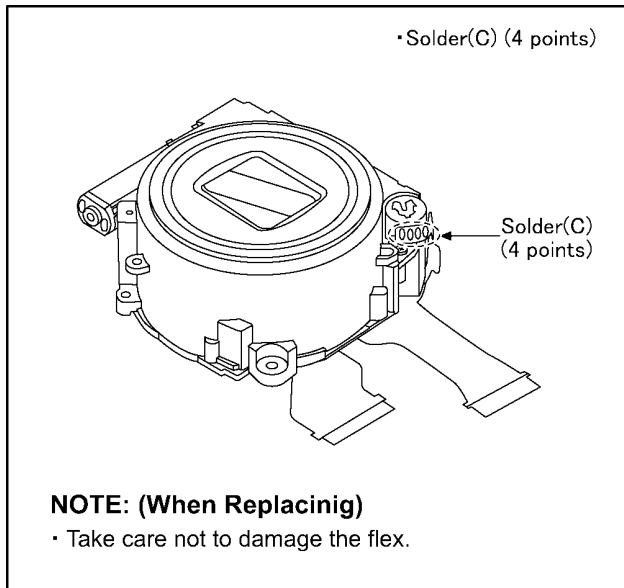

### 8.4.2. Removal of the Master Flange Unit

1. Unscrew the 4 screws (C).

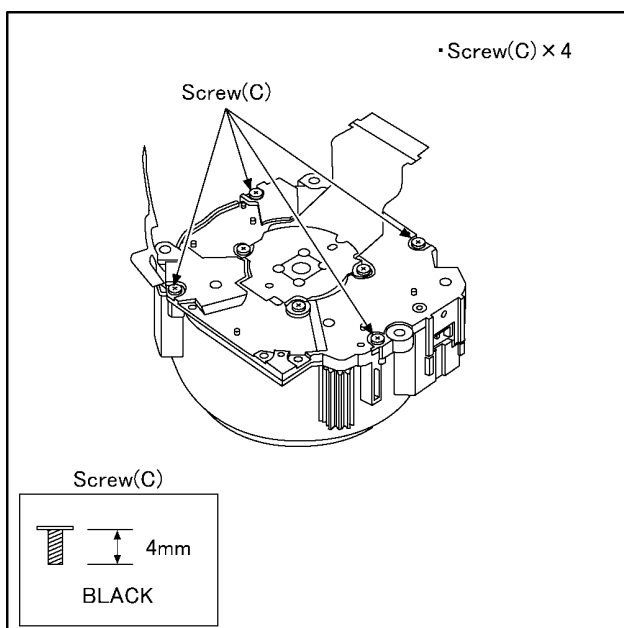

2. Remove the master flange unit.

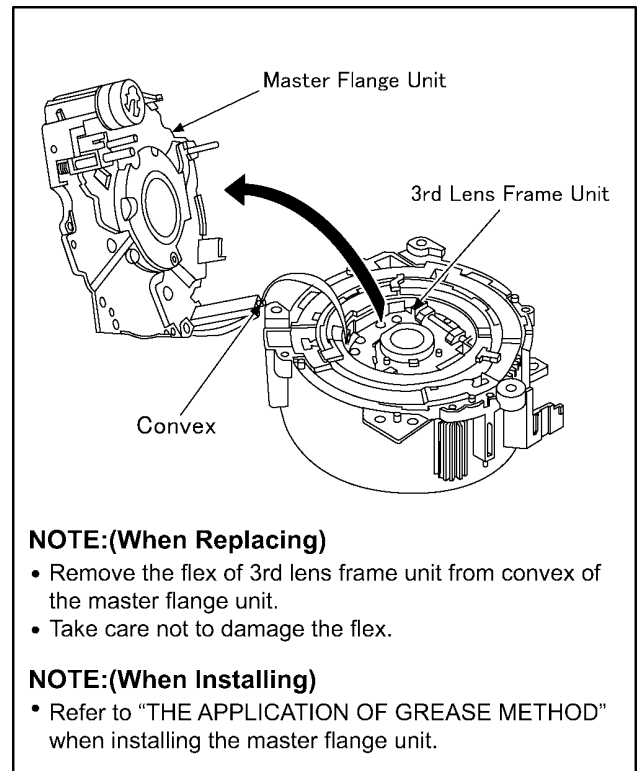

### 8.4.3. Removal of the 1st Lens Frame Unit/2nd Lens Frame Unit/Both Sides Cam Frame/2nd 3rd Direct Frame/3rd Lens Frame Unit

1. Push the both sides cam frame from the lens front side in the direction of arrow, and then remove the unit of 1st lens frame unit/2nd lens frame unit/both sides cam frame/2nd 3rd direct frame/3rd lens frame unit from the fixed frame unit/drive frame unit/penetration cam frame/1st direct frame unit.

#### ■ CAUTION

- The "Drive/Penetration Frame Unit" should be replaced as a unit. Do not replace/exchange only single part, individually.

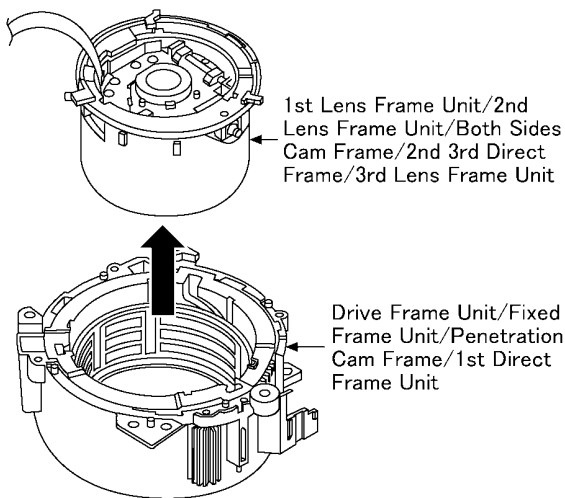

#### NOTE: (When Replacing)

- Take care not to damage the flex.
- When lift the 1st lens frame unit/2nd lens frame unit/both sides cam frame/2nd 3rd direct frame/3rd lens frame unit, take care not to put fingerprint of the lens.

### 8.4.4. Removal of the 2nd Lens Frame Unit/Both Sides Cam Frame/2nd 3rd Direct Frame/3rd Lens Frame Unit

1. Turn the 2nd lens frame unit/both sides cam frame/2nd 3rd direct frame/3rd lens frame unit in the direction of the arrow (1) fully, and then remove them in the direction of the arrow (2).

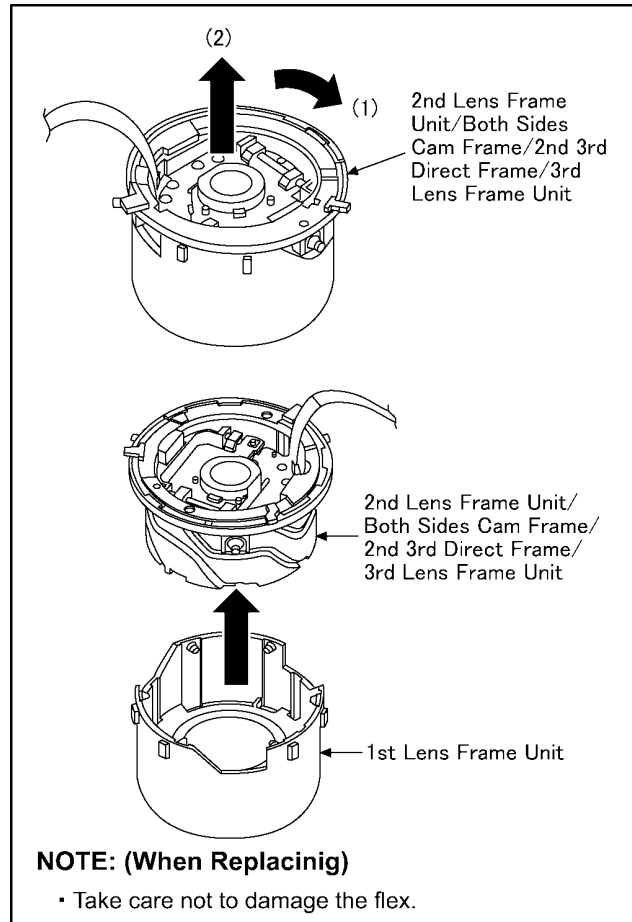

#### NOTE: (When Replacinig)

- Take care not to damage the flex.

### 8.4.5. Removal of the 2nd 3rd Direct Frame

1. Remove the 2nd 3rd direct frame in the direction of the arrow.

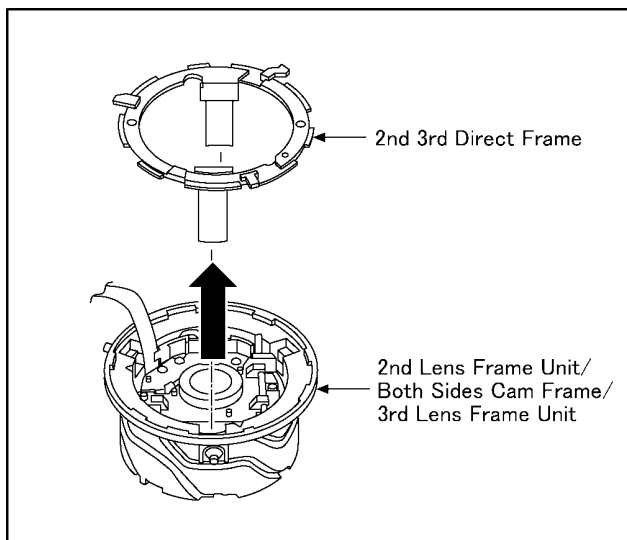

### 8.4.6. Removal of the 3rd Lens Frame Unit

1. Remove the 3rd lens frame unit in the direction of the arrow.

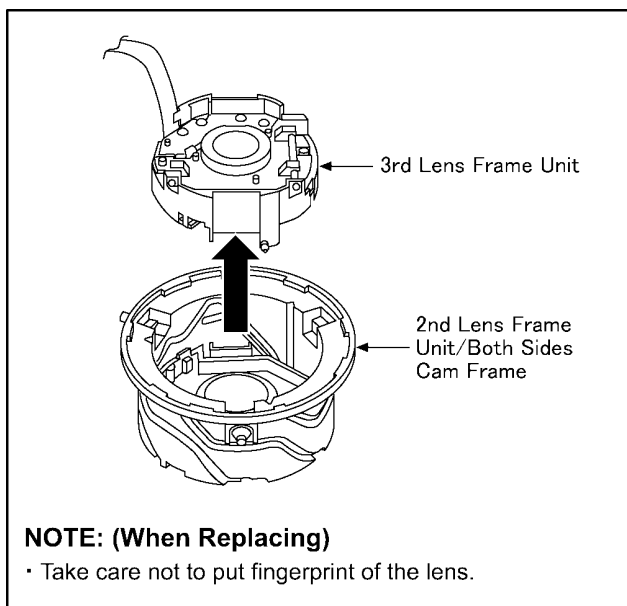

### 8.4.7. Removal of the 2nd Lens Frame Unit

1. Turn the 2nd lens frame unit in the direction of the arrow (1) fully, and then remove it in the direction of the arrow (2).

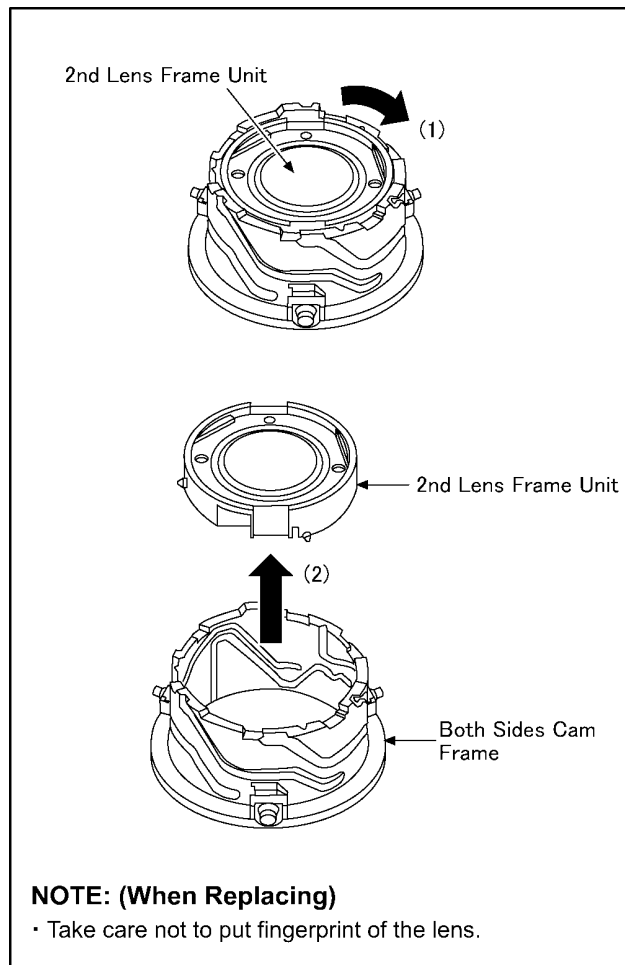

### 8.4.8. Removal of the 1st Direct Frame Unit

1. Remove the 1st direct frame unit in the direction of the arrow.

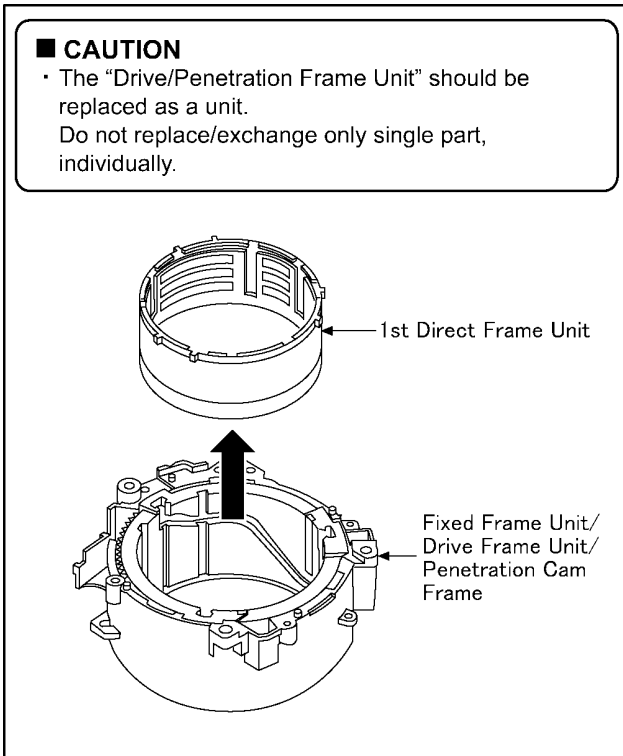

### 8.4.9. Removal of the Drive/Penetration Frame Unit

1. Remove the drive/penetration frame unit in the direction of the arrow.

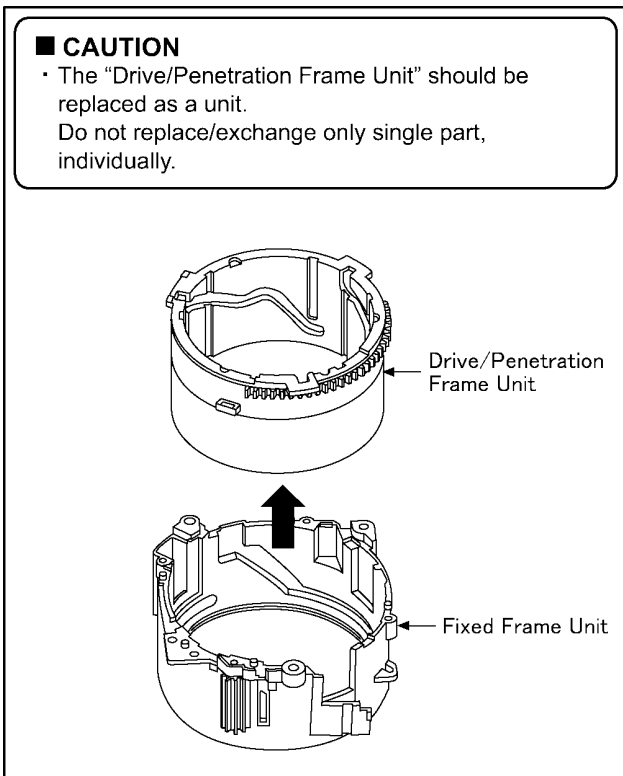

## 8.5. Assembly Procedure for the Lens

### 8.5.1. Phase alignment of the Penetration Cam Frame and Drive Frame Unit

1. Insert the shading sheet to drive frame unit.  
(When insert the shading sheet, so that the luster side facing to subject side.)
2. Set the projection part(most wide) of penetration cam frame at the upper left and the gear part of drive frame unit at the lower right, and then install the penetration cam frame to drive frame unit.

Set the projection part(most wide) at the upper left.

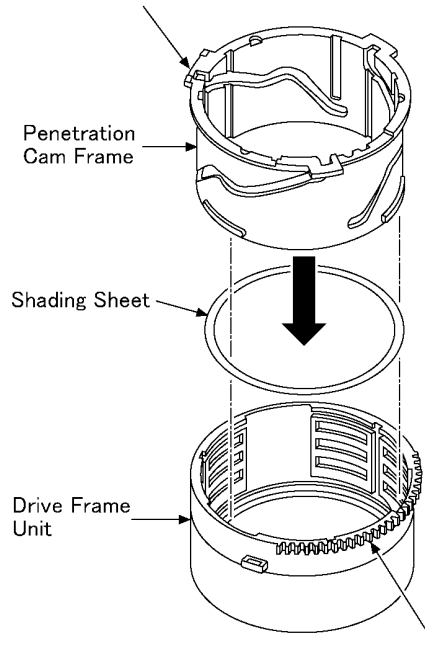

Set the gear part at the lower right.

- Align the phase of the groove of penetration cam frame and the groove of drive frame unit (3 points).

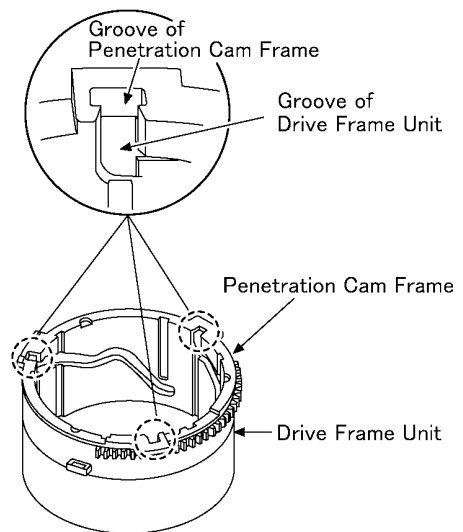



### 8.5.2. Phase alignment of the Drive Penetration Frame Unit and Fixed Frame Unit

1. Align the projection part(most wide) of drive/penetration frame unit and the flex insert part of fixed frame unit.
2. Align the convex part of drive/penetration frame unit and the groove of fixed frame unit, and then install the drive/penetration frame unit to fixed frame unit.

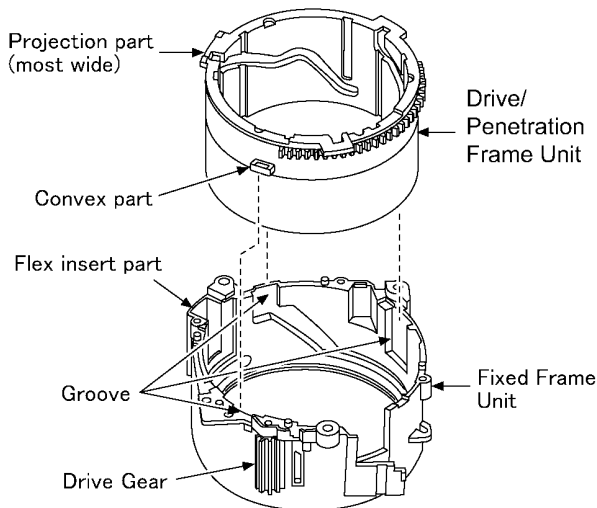

**NOTE: (When Installing)**

- With aligning the phase of the drive/penetration frame unit and the fixed frame unit, confirm the gear of drive frame unit is engaged with the gear of fixed frame unit firmly.

### 8.5.3. Phase alignment of the 2nd Lens Frame Unit and Both Sides Cam Frame

1. Set the No. mark of 2nd lens frame unit at the upper side and the concave part(most large) of both sides cam frame at the left.
2. Align the convex of 2nd lens frame unit and the groove of both sides cam frame, and then install the 2nd lens frame unit to both sides cam frame.

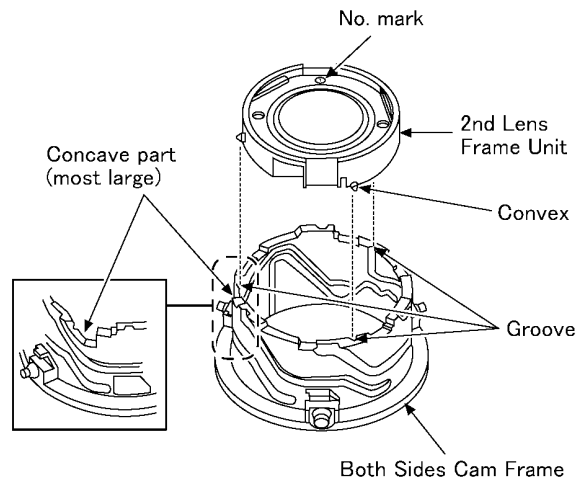

**NOTE: (When Installing)**

- Take care not to put fingerprint of the lens.

### 8.5.4. Phase alignment of the 3rd Lens Frame Unit and 2nd Lens Frame Unit/Both Sides Cam Frame

1. Set the concave part(flex side) of 3rd lens frame unit at the upper side and the concave(most large) of 2nd lens frame unit/both sides cam frame at the right.
2. Align the convex of 3rd lens frame unit and the groove of 2nd lens frame unit/both sides cam frame, and then install the 3rd lens frame unit to 2nd lens frame unit/both sides cam frame.

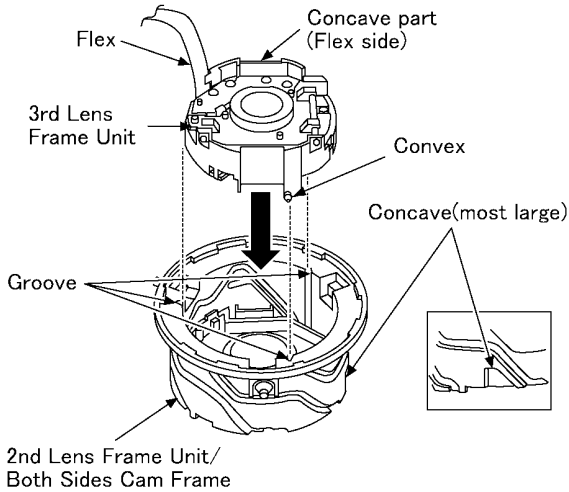

**NOTE: (When Installing)**

- Take care not to put fingerprint of the lens.
- Take care not to damage the flex.

### 8.5.5. Phase alignment of the 2nd 3rd Direct Frame and 2nd Lens Frame Unit/Both Sides Cam Frame/3rd Lens Frame Unit

- Align the projection part(curved) of 2nd 3rd direct frame and the concave part(flex side) of 2nd lens frame unit/both sides cam frame/3rd lens frame unit, and then install the 2nd 3rd direct frame to 2nd lens frame unit/both sides cam frame/3rd lens frame unit.

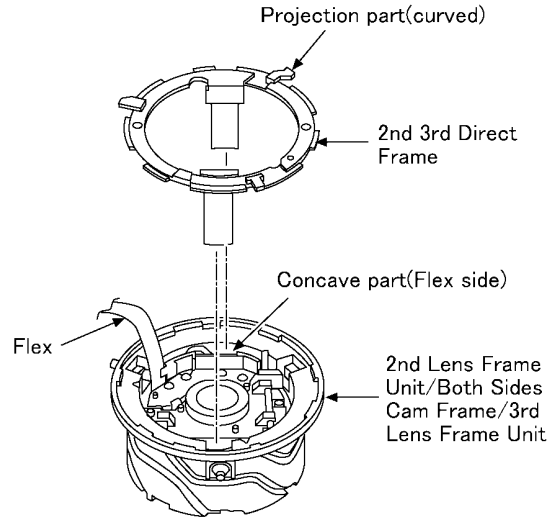

**NOTE: (When Installing)**

- Take care not to put fingerprint of the lens.

### 8.5.6. Phase alignment of the 2nd Lens Frame Unit/Both Sides Cam Frame/2nd 3rd Direct Frame/3rd Lens Frame Unit and 1st Lens Frame Unit

1. Set the flex part of 2nd lens frame unit/both sides cam frame/2nd 3rd direct frame/3rd lens frame unit at the upper side.

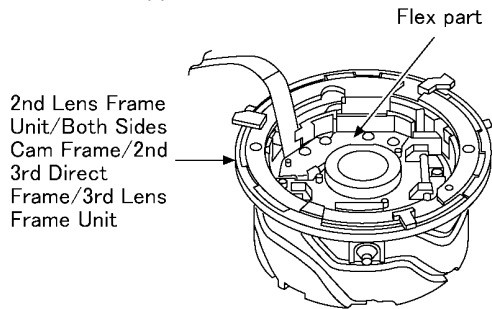

2. Rotate the 2nd lens frame unit/both sides cam frame/2nd 3rd direct frame/3rd lens frame unit in a clockwise direction approx. 110 degrees.

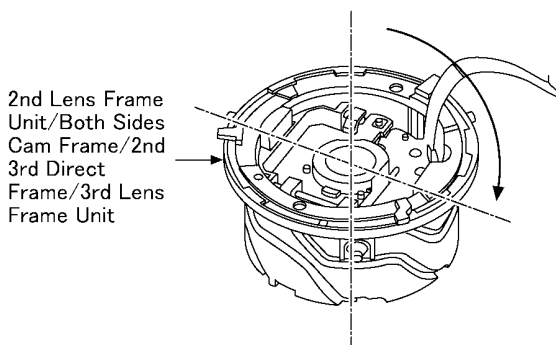

3. Set the "LUMIX DC VARIO" character on the front side of 1st lens frame unit at the upper side.
4. Align the groove of 2nd lens frame unit/both sides cam frame/2nd 3rd direct frame/3rd lens frame unit and the convex of 1st lens frame unit, and then install the 2nd lens frame unit/both sides cam frame/2nd 3rd direct frame/3rd lens frame unit to 1st lens frame unit. (The 2nd lens frame unit/both sides cam frame/2nd 3rd direct frame/3rd lens frame unit rotates in a counterclockwise direction while installing.)

2nd Lens Frame Unit/Both Sides Cam Frame/2nd 3rd Direct Frame/3rd Lens Frame Unit

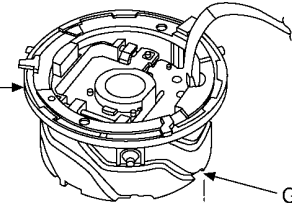

Groove

Convex

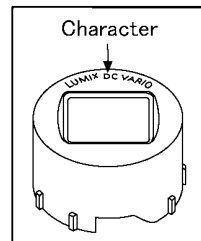

1st Lens Frame Unit

5. The flex part of 2nd lens frame unit/both sides cam frame/2nd 3rd direct frame/3rd lens frame unit is seen at the upper side when install is finished.

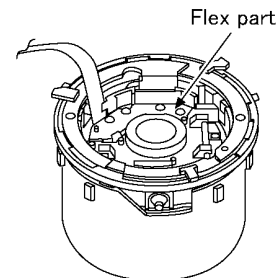

#### NOTE: (When Installing)

- Take care not to put fingerprint of the lens.
- Take care not to damage the flex.

### 8.5.7. Phase alignment of the 1st Lens Frame Unit/2nd Lens Frame Unit/ Both Sides Cam Frame/2nd 3rd Direct Frame/3rd Lens Frame Unit and 1st Direct Frame Unit

1. Set the flex part of 1st lens frame unit/2nd lens frame unit/both sides cam frame/2nd 3rd direct frame/3rd lens frame unit at the upper side and the projection part(most wide) of 1st direct frame unit at the upper left side.
2. Align the convex part of 1st lens frame unit/2nd lens frame unit/both sides cam frame/2nd 3rd direct frame /3rd lens frame unit and the groove of 1st direct frame unit, and then install the 1st lens frame unit/ 2nd lens frame unit/both sides cam frame/2nd 3rd direct frame/3rd lens frame unit to 1st direct frame unit.

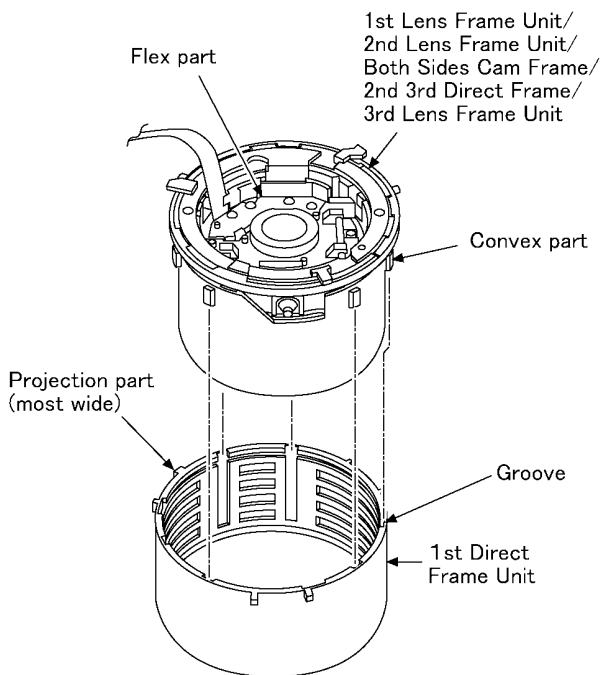

**NOTE: (When Installing)**

- Take care not to put fingerprint of the lens.
- Take care not to damage the flex.

### 8.5.8. Phase alignment of the 1st Direct Frame Unit/1st Lens Frame Unit/ 2nd Lens Frame Unit/Both Sides Cam Frame/2nd 3rd Direct Frame/ 3rd Lens Frame Unit and Fixed Frame Unit/Drive Frame Unit/Pene- tration Cam Frame

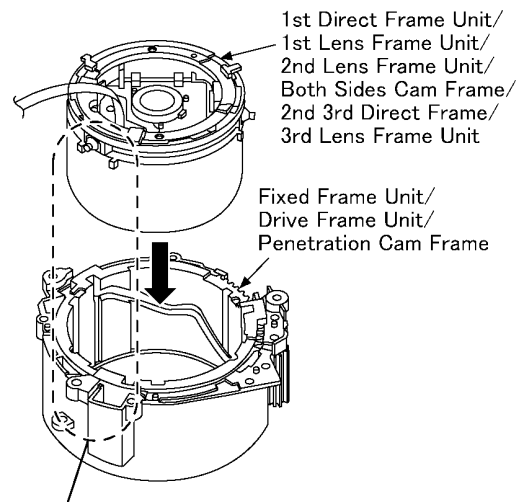

- Insert the convex(1), convex(2) and convex(3) to grooves(a,b,c) in order.

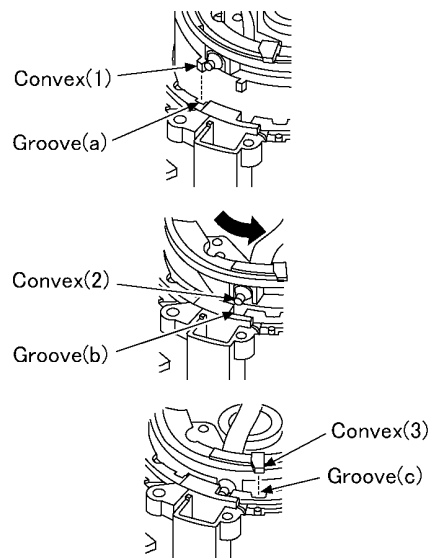

**FRONT VIEW**

- Install the 1st lens frame unit so that the "LUMIX DC VARIO" character may become the position of the figure below.

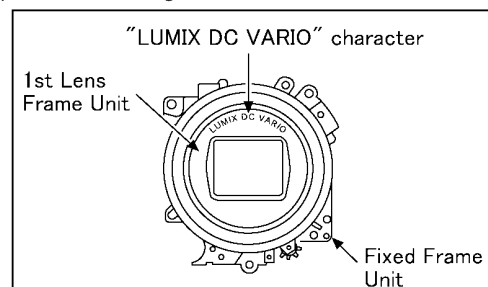

### 8.5.9. Install of the Master Flange Unit

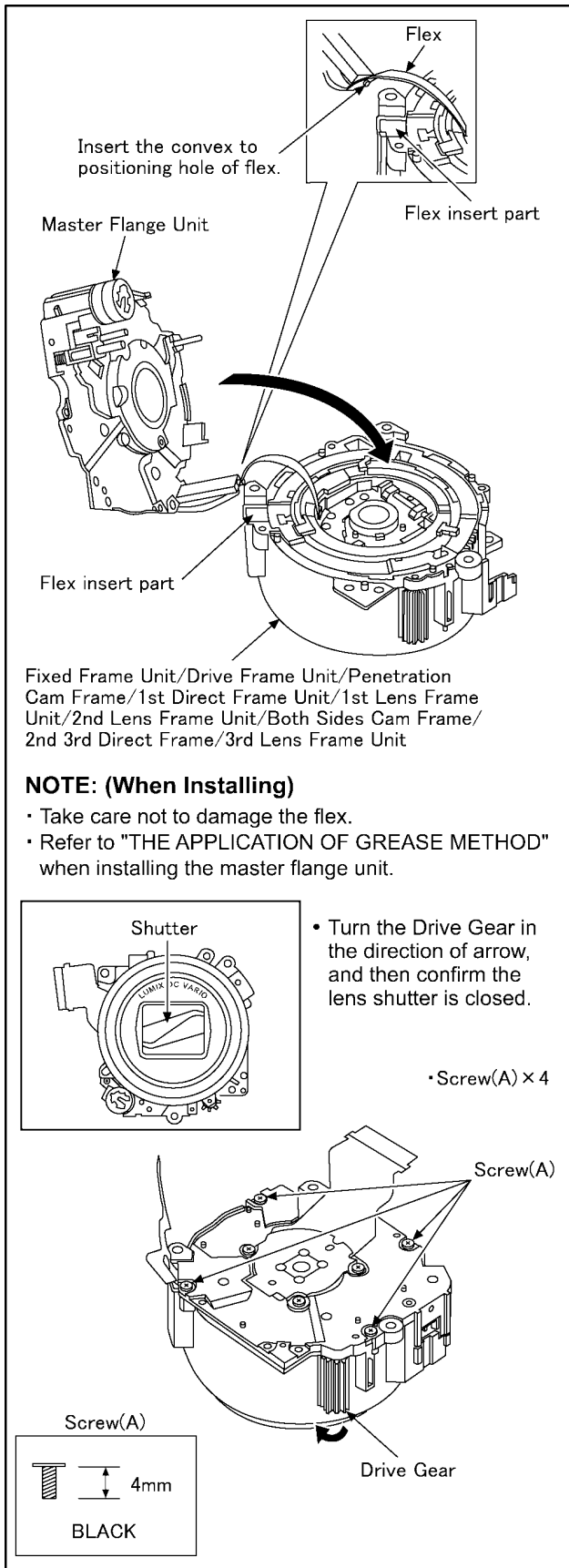

### 8.5.10. Install of the Lens FPC Unit and Zoom Motor

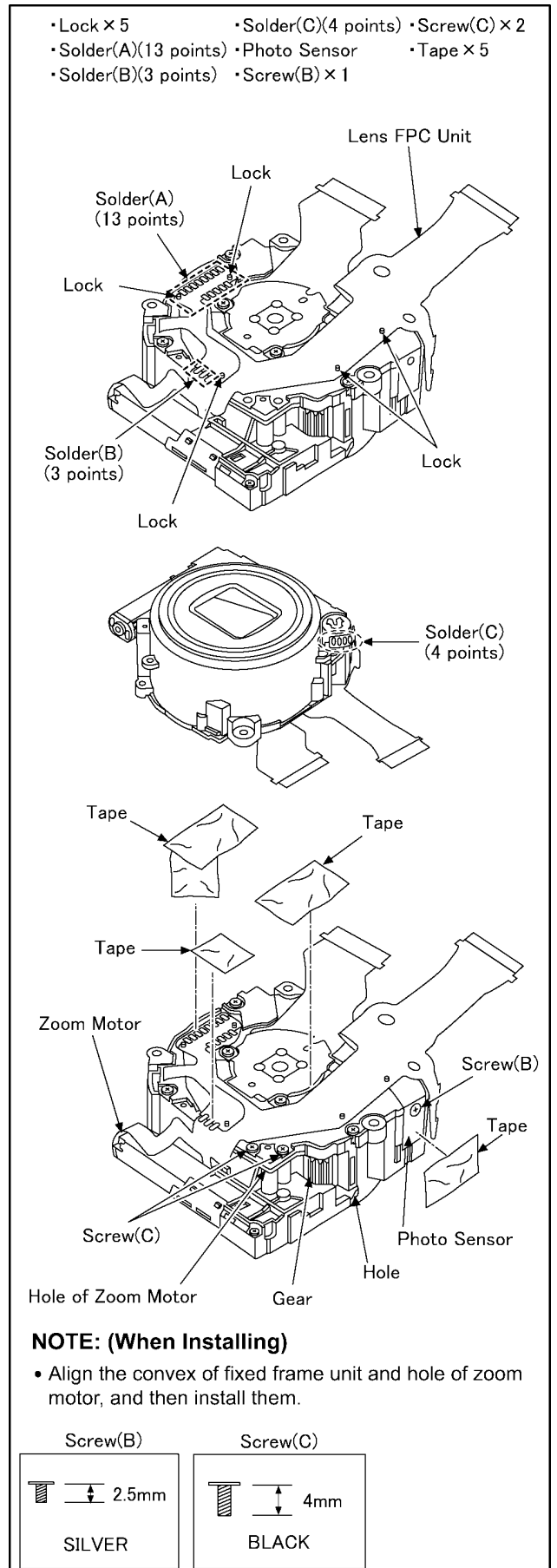

## 8.6. Removal of the CCD Unit

To prevent the CCD unit from catching the dust and dirt, do not remove the CCD unit except for replacing.

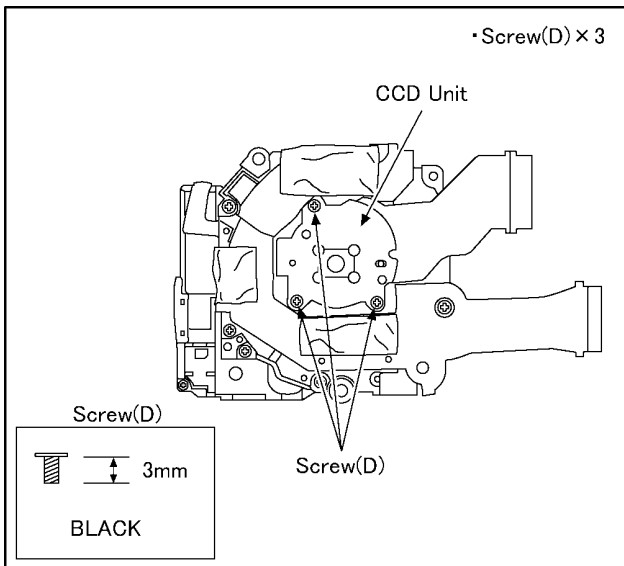

## 8.7. Removal of the Focus Motor Unit

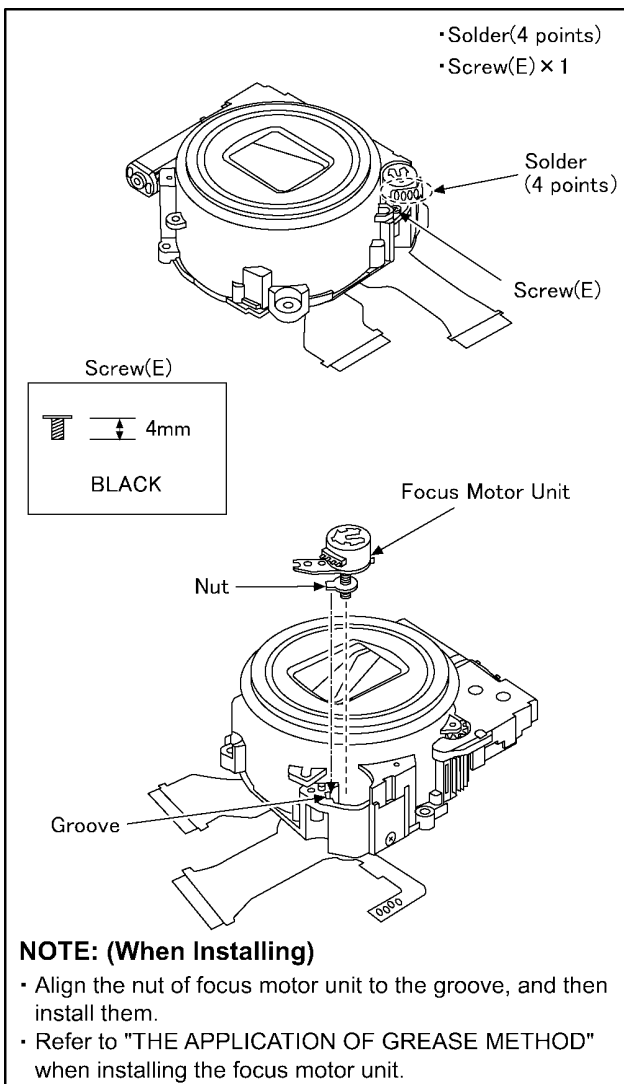

## 8.8. The Application of Grease Method

The grease application parts of lens unit are as follows.

Apply grease additionally in the specified position if necessary. When the grease is applied, use a toothpick and apply thinly.

- Focus motor unit (lead screw)/Fasten groove of nut/Guide pole
  - Grease: RFKZ0472
  - Amount of application: 2 - 4 mg
- Positioning pole
  - Grease: RFKZ0472
  - Amount of application: 1 - 2 mg

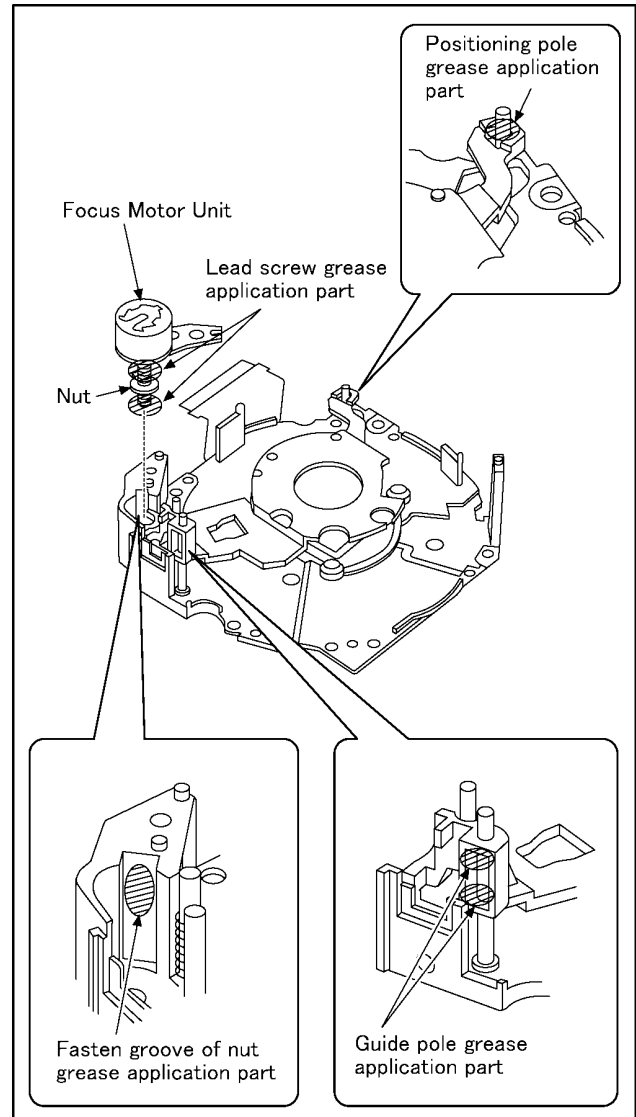

# 9 Measurements and Adjustments

## 9.1. Introduction

When servicing this unit, make sure to perform the adjustments necessary based on the part(s) replaced. Before disassembling the unit, it is recommended to back up the camera data stored in flash-rom as a data file.

### **IMPORTANT NOTICE (After replacing the MAIN P.C.B.)**

After replacing the MAIN P.C.B., it is necessary to use the "DIAS" software to allow the release of adjustment flag(s).

The Adjustment software "DIAS" is available at "TSN Website". To download, click on "Support Information from NWBG/VDBG-AVC".

\*DIAS (DSC Integrated Assist Software)

## 9.2. Before Disassembling the unit

### 9.2.1. Initial Setting Release

The cameras specification are initially set in accordance with model suffix (such as EB, EG, GK, GC, and so on.).

Unless the initial setting is not released, an automatic alignment software in the camera is not able to be executed when the alignment is carried out.

#### **Note:**

The initial setting should be again done after completing the alignment. Otherwise, the camera may not work properly.

Therefore as a warning, the camera display a warning symbol "!" on the LCD monitor every time the camera is turned off.

Refer to the procedure described in "3.4.2 INITIAL SETTINGS" for details.

#### **[ How to Release the camera initial setting ]**

##### **Preparation:**

1. Attach the Battery or AC Adaptor with a DC coupler to the unit.  
(Since this unit has built-in memory, it can be performed without inserting SD memory card.)
2. Set the recording mode to the [ NORMAL PICTURE ] mode.  
(Press the [ MODE ] button and select the [ NORMAL PICTURE ] by pressing the "[ UP ] and [ DOWN ] of Cursor buttons", then press the [ MENU/SET ] button.)

##### **Step 1. Temporary cancellation of "INITIAL SETTINGS":**

Set the [ REC ]/[ PLAYBACK ] selector switch to "[ REC ] (Camera mark)".

While keep pressing "[ UP ] of Cursor button" and [ iA ] button simultaneously, turn the Power on.

##### **Step 2. Cancellation of "INITIAL SETTINGS":**

Set the [ REC ]/[ PLAYBACK ] selector switch to "[ PLAYBACK ]".

Press "[ UP ] of Cursor button" and [ iA ] button simultaneously. (The camera will beep after this.)

Turn the Power off. (The warning symbol "!" is displayed on the LCD monitor.)

## 9.2.2. Flash-Rom Data Backup

When trouble occurs, it is recommended to backup the Flash-rom data before disassembling the unit.

There are two kinds of Flash-rom data backup methods:

### [ ROM\_BACKUP (Method of Non-PC backup) ]

1. Insert the SD-card into the camera.
2. Set the camera to "Temporary cancellation of the initial settings".
3. Select the "SETUP" menu.  
From the "SETUP" menu, select "ROM BACKUP".

#### NOTE:

This item is not listed on the customer's "SETUP" menu.

4. When this "ROM\_BACKUP" item is selected, the following submenus are displayed.



Item	Function	Details
DSC → SD	Save all the DSC's Flash-rom data to SD-CARD	*DSC's Flash-rom data is saved to the SD-CARD as a data file by the same format as the TATSUJIN software for the previous models. (DATA BACKUP) -File location: ROOT DIRECTORY in SD-CARD. -File Name: 1) User Setup Information data: <Model Number>U.txt [Example: DMC-FX66 : "FX66U.txt"] 2) Optical Adjustment data: <Model Number>F.txt [Example: DMC-FX66 : "FX66F.txt"] *If the concerned file already exists, "OVERWRITE?" message is displayed.
SDALL → DSC (ID CHECK)	Write the all data to DSC's Flash-rom from SD-CARD	*The backup data being stored in the SD card is transferred to DSC unit. *ID CHECK: When the model ID is different, data is not transferred.
SDALL → DSC (FORCE)	Write the all data to DSC's Flash-rom from SD-CARD	*FORCE: Even if the model ID is different, data is transferred. ※If the main PCB is replaced, select "SDALL → DSC (FORCE)".
SDUSER → DSC (FORCE)	Only "User setup information" is written from the saved file in the SD-CARD to DSC's Flash-rom.	*Only the user's "setup" setting condition is transferred to DSC unit. *FORCE: Even if the model ID is different, the data is transferred.
! → LUMIX	Shipping set without initializing "User setup information"	*Initial setting is executed without initializing the user's set up setting condition. ※ The initial setting must be perform while the Self-timer LED is blinking. ※ The picture data stored in the built-in memory of the DSC is not erased, with this operation.

### [ DSC Integrated Assist Software (Method of Using PC) ]

Same as TATSUJIN software for previous models.

## 9.2.3. Light Box

If using VFK1164TDVLB Light Box, remove the lens connection ring by loosening three hexagon screws.

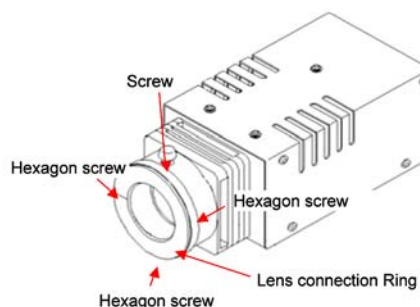



## 9.3. Details of Electrical Adjustment

### 9.3.1. How to execute the Electrical Adjustment

It is not necessary to connect the camera to a PC to perform adjustments.

“Flag reset operation” and “Initial setting operation” are required when carrying out the alignment, follow the procedure below.

#### 9.3.1.1. Startup Electrical Adjustment mode

1. Release the initial settings.
2. Insert a recordable SD card.  
(Without a SD card, the automatic adjustment can not executed.)
3. Procedure to set the camera into adjustment mode:
  - a. Set the mode into [ NORMAL PICTURE ] mode.
  - b. Set the [ REC/PLAYBACK ] selector switch to “[ REC ](Camera mark)”.
  - c. Turn the Power off.
  - d. Turn the Power on pressing [ DISPLAY ] and [ MENU/SET ] simultaneously.  
LCD monitor displays “SERVICE MODE”.(Refer to Fig. 3-1)



Fig. 3-1

#### 9.3.1.2. Status Adjustment Flag Setting

Reset (Not yet adjusted) the status flag condition.

1. After pressing the [ DISPLAY ] button, the LCD monitor displays the Flag status screen (Refer to Fig.3-2)
2. Select item by pressing the Cursor buttons. (Gray cursor is moved accordingly.)
3. Press the [ Delete ] button.

**NOTE:**

The selected item's flag has been changed from “F (green)” to “0 (yellow)”.

\*(Refer to Fig. 3-3)

\*Flag conditions:

F (green)

means that the alignment has been completed and the status flag condition is set. In this case, the flag condition should be reset, if you try to carry out the automatic alignment.

0 (yellow)

means that the alignment has been not “completed” and the status flag condition is “reset”. In this case, automatic alignment is available.

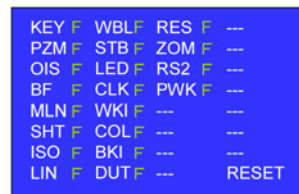

Fig. 3-2



Fig. 3-3

<Example: OIS flag is reset. >

- In case of setting the status flag into set condition again without completion of the alignment, the status flag should be SET by using PC, or UNDO by using ROM BACKUP function.

### 9.3.1.3. Execute Adjustment (In case of “OIS Adjustment”)

1. Perform step “9.3.1.1.” to “9.3.1.2.”, to reset the OIS flag status “F” (Set) to “0” (Reset)
2. Press [ DISPLAY ] button after Flag reset.  
OIS Adjustment screen is displayed on the LCD panel.  
(Refer to Fig.3-4)
3. Press the [ Shutter ] button. The adjustment will start automatically.



Fig. 3-4

4. When the adjustment is completed successfully, adjustment report menu appears with Green OK on the LCD monitor. (Refer to Fig.3-5)



Fig. 3-5

### 9.3.1.4. Attention point during Adjustment

1. Step “9.3.1.3.” procedure shows OIS adjustment as an example. To perform the adjustment, refer to the “9.3.2. Adjustment Specifications” table which shows key point for each adjustment.
2. Do not move the light box, the camera or the chart while adjusting. If one of these is moved accidentally, start the adjustment again.
3. Do not press any buttons/keys until the default menu (Fig.3-6) is displayed on the LCD monitor. Otherwise, adjustment data may not be stored properly.
4. If the adjustment is interrupted accidentally, the alignment data may not be properly saved in the Flash-rom.



Fig. 3-6

### 9.3.1.5. Finalizing the Adjustment

1. Several adjustment flags can be reset (“F” into “0”) at the same time. In this case, when the adjustment has been completed, the screen will change showing the adjustment for the next item until all reset items are completed.  
Also, when the shutter button is pressed, the screen jump to the next adjustment item.
2. To cancel the adjustment mode while in the process of performing the adjustment, follow this procedures.
  - (1) Press [ Delete ] button.
  - (2) Press [ RIGHT ] of Cursor button.

#### NOTE:

- If adjustment is cancelled with above procedure, adjustment is not completed. Make sure to adjust it later.
- Adjustment software “DIAS” is able to control the status of the adjustment flags.

### 9.3.2. Adjustment Specifications

The following matrix table shows the relation between the replaced part and the Necessary Adjustment. When a part is replaced, make sure to perform the necessary adjustment(s) in the order indicated. The table below shows all the information necessary to perform each adjustment.

Adjustment Item	FLAG	Purpose	Replacing Parts					JIG/TOOLS	SET UP	How to Operate	
			MAIN PCB	VENUS (IC6001)	MCP(IC6002)	Lens Parts (except for CCD)	CCD Unit				GYRO (IC7101)
1 Venus Zoom	PZM	Venus Zoom Inspection	○	○	○	—	—	NONE	NONE	1) Press Shutter Button 2) After displaying "PZM", press Shutter Button again. 3) After completed, the "OK" menu appears.	
2 OIS sensor	OIS	OIS sensor output level adjustment	○	○	○	○	—	NONE	NONE	1) Press Shutter Button (Do not offer any shock and vibration for the camera while adjusting) 2) After completed, the "OK" menu appears.	
3 Backfocus / GYRO	BF	To have the focus tracking curve be appropriate shape and GYRO sensor adjustment	○	○	○	○	※1	○	<p>*COLLIMATOR (VFK1164TCM02 or VFK1164TCM03 or RFKZ0422)</p> <p>1) Set the camera in front of collimator so that the distance from collimator to camera becomes about 4 cm as shown in Fig.A.  <b>[NOTE]</b>                      Please notice! "NG" might happen while auto adjusting.                      - Do not put the black colored stuff at the back side of collimator near hunching chart to get some certain brightness.                      - Make sure the hunching chart has no dust and dirty condition.                      - Not connect the USB cable at this stage.</p>	1) Press Shutter Button (Do not offer any shock and vibration for the camera while adjusting) 2) Press Shutter Button again after displayed "green circle" on LCD display 3) After completed, the "OK" menu appears.	
4 Monitor Linearity	MLN	Monitor Linearity adjustment	○	○	○	○	○	—	<p>*LIGHT BOX (VFK1164TDVLB or RFKZ0523)</p> <p>1) Set the camera in front of LIGHTBOX so that the distance from collimator to camera becomes about 15 cm as shown in Fig.B.</p>	1) Press Shutter Button 2) After completed, the "OK" menu appears.	
5 Shutter	SHT	Shutter speed adjustment	○	○	○	○	○	—	<p>*LIGHT BOX (VFK1164TDVLB or RFKZ0523) *TR CHART (RFKZ0443)</p> <p>1) Insert the TR chart into the slot of LIGHTBOX. 2) Set the camera in front of LIGHTBOX so that the distance from LIGHTBOX to camera becomes about 15 cm as shown in Fig.B. 3) Set the camera angle so that the color chart is displayed on the LCD monitor fully.  <b>[NOTE]</b>                      - Since the lens position is automatically set into certain position after executing auto adjustment, confirm the angle after stopping the lens zoom position.                      - It is no problem even though the chart on to the LCD monitor slightly cut at the corner.                      - It is no problem even though the focusing slightly becomes out of focusing condition.                      - Not connect the USB cable at this stage.</p>	1) Press Shutter Button 2) After completed, the "OK" menu appears.	
6 ISO	ISO	ISO sensitivity adjustment	○	○	○	○	○	—		1) Press Shutter Button 2) After completed, the "OK" menu appears.	
7 White Balance	WBL	White balance adjustment under various color temperature	○	○	○	○	○	—		1) Press Shutter Button 2) After completed, the "OK" menu appears.	
8 High brightness coloration	LIN	High brightness coloration adjustment	○	○	○	○	○	—		1) Press Shutter Button 2) After completed, the "OK" menu appears.	
9 CCD Missing Pixels (White)	WKI	Compensation of CCD Missing Pixels (White)	○	○	○	—	○	※1	NONE	NONE	1) Press Shutter Button 2) After completed, the "OK" menu appears.
10 Color reproduction inspection and Microphone check	COL	Color reproduction inspection and Microphone check	○	○	○	○	○	—	NONE	NONE	1) Press Shutter Button 2) After completed, the "OK" menu appears.
11 CCD Missing Pixels (Black)	BKI	Compensation of CCD Missing Pixels (Black)	○	○	○	—	○	※1	<p>*LIGHT BOX (VFK1164TDVLB or RFKZ0523)</p> <p>1) Set the camera in front of LIGHTBOX so that the distance from collimator to camera becomes about 15 cm as shown in Fig.B.</p>	1) Press Shutter Button 2) After completed, the "OK" menu appears.	

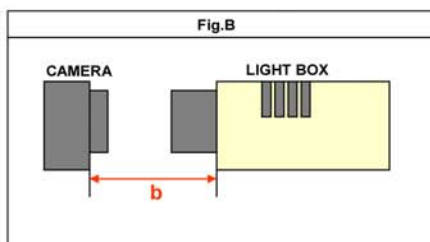
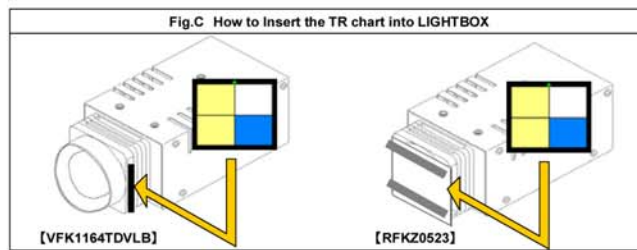
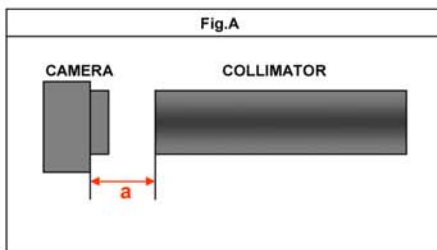

**IMPORTANT NOTICE**(After replacing the MAIN P.C.B. / FLASH\_ROM)

If you intend to proceed adjustment after replacing the MAIN P.C.B. (Include FLASH\_ROM) and/or FLASH\_ROM, it should be execute "INITIAL SETTINGS" FIRST, then release the "INITIAL SETTINGS" in order to proceed the electrical adjustment.

※If electrical adjustment or data re-writing is executed before "INITIAL SETTINGS", suffix code list is never displayed, and it cannot be chosen suitable suffix code.

## **9.4. After Adjustment**

### **9.4.1. Initial Setting**

Since the initial setting has been released to execute the built-in adjustment software, it should be set up again before shipping the camera to the customer.

Refer to the procedure described in "3.4.2. INITIAL SETTINGS" for details.

#### **[ IMPORTANT ]**

1. The initial setting should be done again after completing the alignment. Otherwise, the camera will not work properly.  
Therefore as a warning, the camera display a warning symbol " ! " on the LCD monitor every time the camera is turned off.
2. Confirm that status of all adjustment flag show "F". Even if one of the adjustment flag shows "0", initial setting programmed is never executed.
3. Adjustment software "DIAS" is able to control the status of the adjustment flags.  
The Adjustment software "DIAS" is available at "TSN Website", therefore, access to "TSN Website" at "Support Information from NWBG/VDBG-AVC".

# 10 Maintenance

## 10.1. Cleaning Lens and LCD Panel

Do not touch the surface of lens and LCD Panel with your hand.

When cleaning the lens, use air-Blower to blow off the dust.

When cleaning the LCD Panel, dampen the lens cleaning paper with lens cleaner, and the gently wipe the its surface.

**Note:**

The Lens Cleaning KIT ; VFK1900BK (Only supplied as 10 set/Box) is available as Service Aid.

# Service Manual

---

## Diagrams and Replacement Parts List

### Digital Camera

Model No.

DMC-FS30EB	DMC-FH20GF
DMC-FS30EE	DMC-FH20GN
DMC-FS30EF	DMC-FH20GT
DMC-FS30EG	DMC-FH20P
DMC-FS30EP	DMC-FH20PC
DMC-FH20GC	DMC-FH20PR
DMC-FH20GD	DMC-FH20PU

Vol. 1

Colour

- (S).....Silver Type (except EF/GD/GT/PR)
- (K).....Black Type
- (A).....Blue Type (except EE/GD/GT/PC/PR)
- (V).....Violet Type (except GF/PC)
- (R).....Red Type (only GC/GF/P/PC/PR/PU)

### Table of contents

S1. About Indication of The Schematic Diagram.....	S-1
S1.1. Important Safety Notice.....	S-1
S2. Voltage Chart .....	S-2
S2.1. Flash Top P.C.B.....	S-2
S3. Block Diagram.....	S-3
S3.1. Overall Block Diagram .....	S-3
S4. Schematic Diagram.....	S-4
S4.1. Interconnection Diagram .....	S-4
S4.2. Flash Top Schematic Diagram .....	S-5
S4.3. CCD Flex Schematic Diagram .....	S-6
S4.4. Lens Flex Schematic Diagram .....	S-7
S5. Print Circuit Board.....	S-8
S5.1. Flash Top P.C.B.....	S-8
S5.2. CCD Flex P.C.B.....	S-9
S5.3. Lens Flex P.C.B.....	S-10

S6. Replacement Parts List.....	S-11
S7. Exploded View .....	S-16
S7.1. Frame and Casing Section.....	S-16
S7.2. Packing Parts and Accessories Section (1) .....	S-17
S7.3. Packing Parts and Accessories Section (2) .....	S-18

## S1. About Indication of The Schematic Diagram

### S1.1. Important Safety Notice

COMPONENTS IDENTIFIED WITH THE MARK  $\triangle$  HAVE THE SPECIAL CHARACTERISTICS FOR SAFETY. WHEN REPLACING ANY OF THESE COMPONENTS USE ONLY THE SAME TYPE.

1. Although reference number of the parts is indicated on the P.C.B. drawing and/or schematic diagrams, it is NOT mounted on the P.C.B. when it is displayed with "\$" mark.
2. It is only the "Test Round" and no terminal (Pin) is available on the P.C.B. when the TP (Test Point) indicated as "●" mark.
3. The voltage being indicated on the schematic diagram is measured in "Standard-Playback" mode when there is no specify mode is mentioned.
4. Although the voltage and waveform available on here is measured with standard frame, it may be differ from actual measurement due to modification of circuit and so on.
5. The voltage being indicated here may be include observational-error (deviation) due to internal-resistance and/or reactance of equipment. Therefore, handle the value indicated on here as reference.
6. Use the parts number indicated on the Replacement Parts List .
7. Indication on Schematic diagrams:

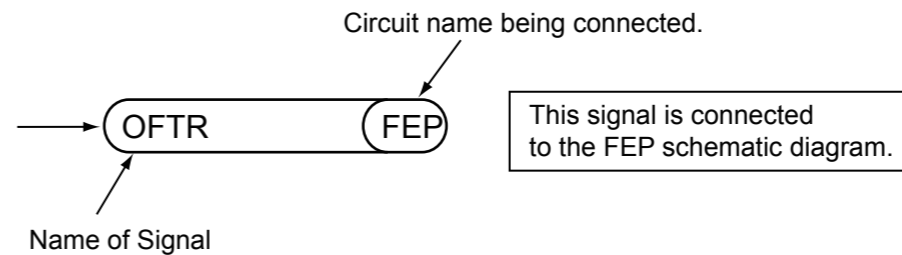

## S2. Voltage Chart

Note) Indicated voltage values are the standard values for the unit measured by the DC electronic circuit tester (high-impedance) with the chassis taken as standard.  
Therefore, there may exist some errors in the voltage values, depending on the internal impedance of the DC circuit tester.

### S2.1. Flash Top P.C.B.

REF No.	PIN No.	POWER ON
IC8100	1	0
IC8100	2	0
IC8100	3	0
IC8100	4	0
IC8100	5	3.0
IC8100	6	0
IC8100	7	0
IC8100	8	0
IC8100	9	3.0
IC8100	10	3.6

# S3. Block Diagram

## S3.1. Overall Block Diagram

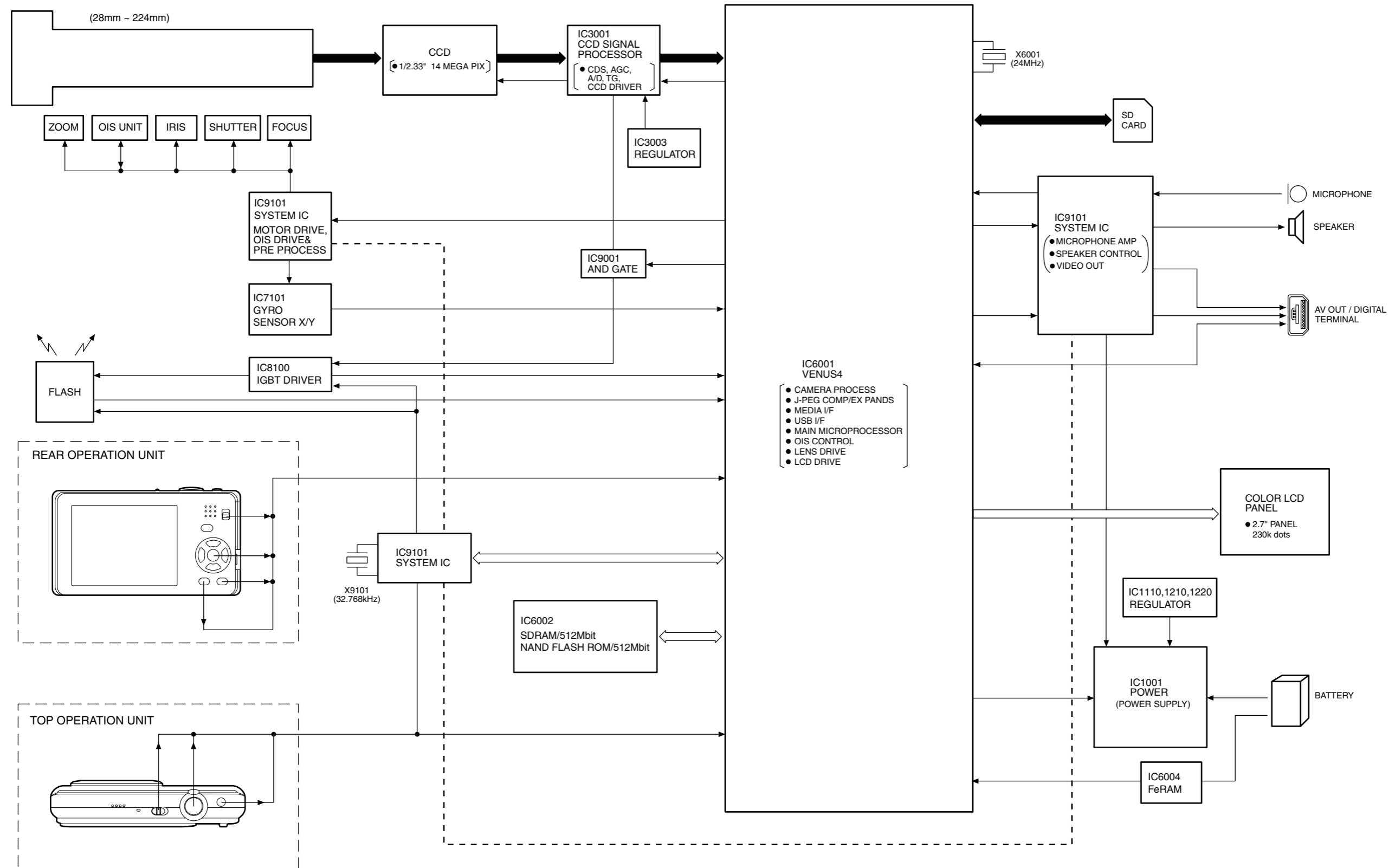



# S4. Schematic Diagram

## S4.1. Interconnection Diagram

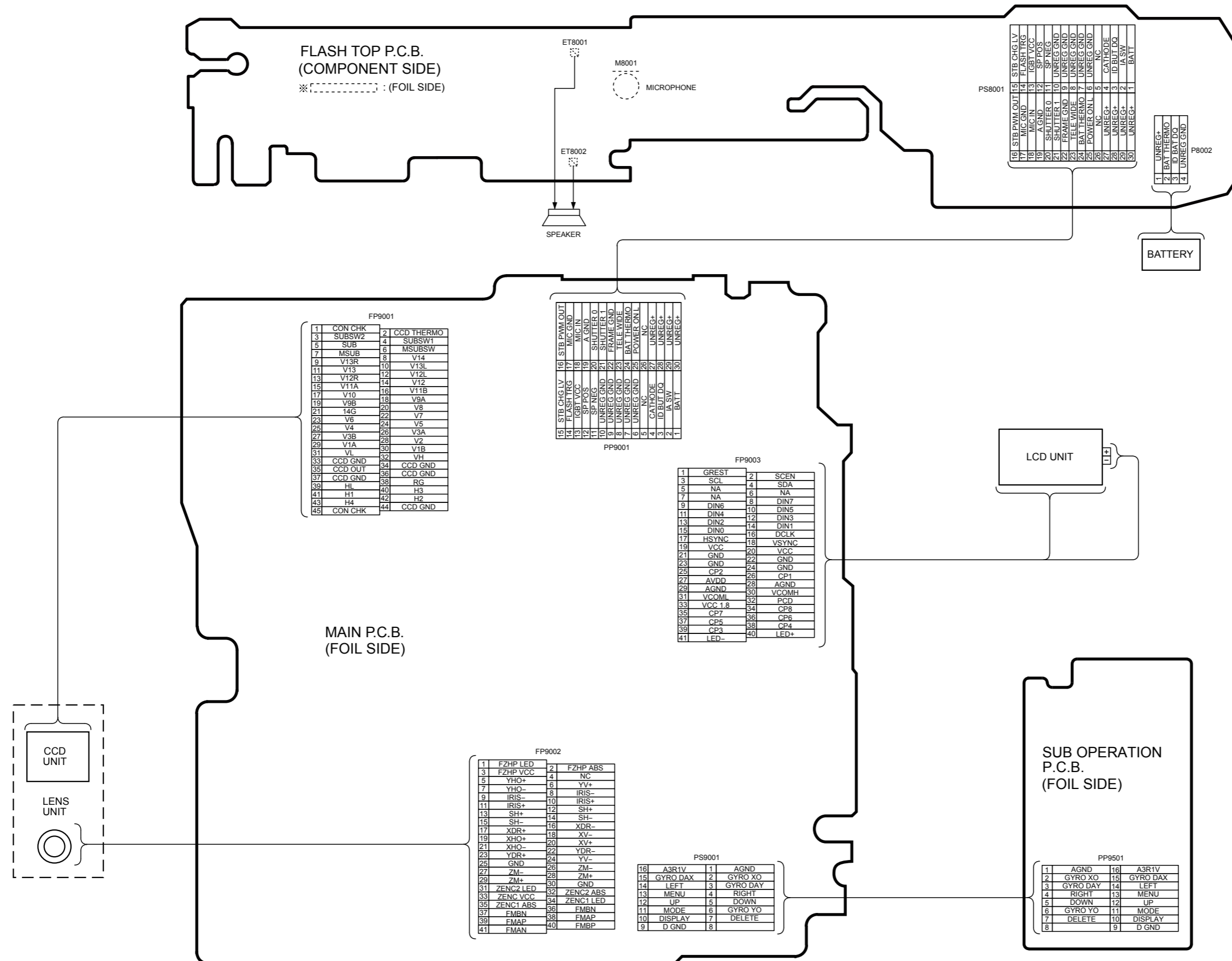

# S4.2. Flash Top Schematic Diagram

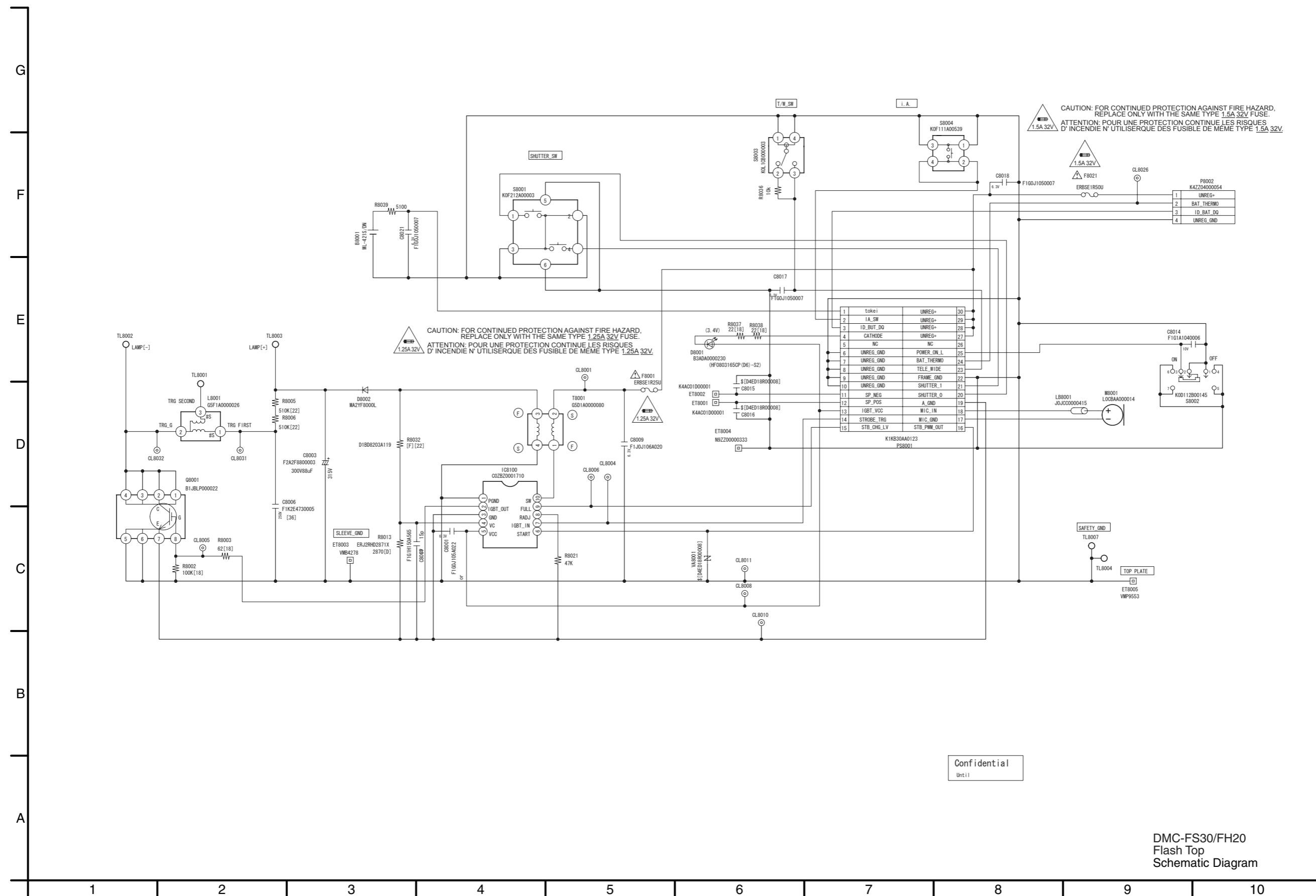

Confidential  
Until

### S4.3. CCD Flex Schematic Diagram

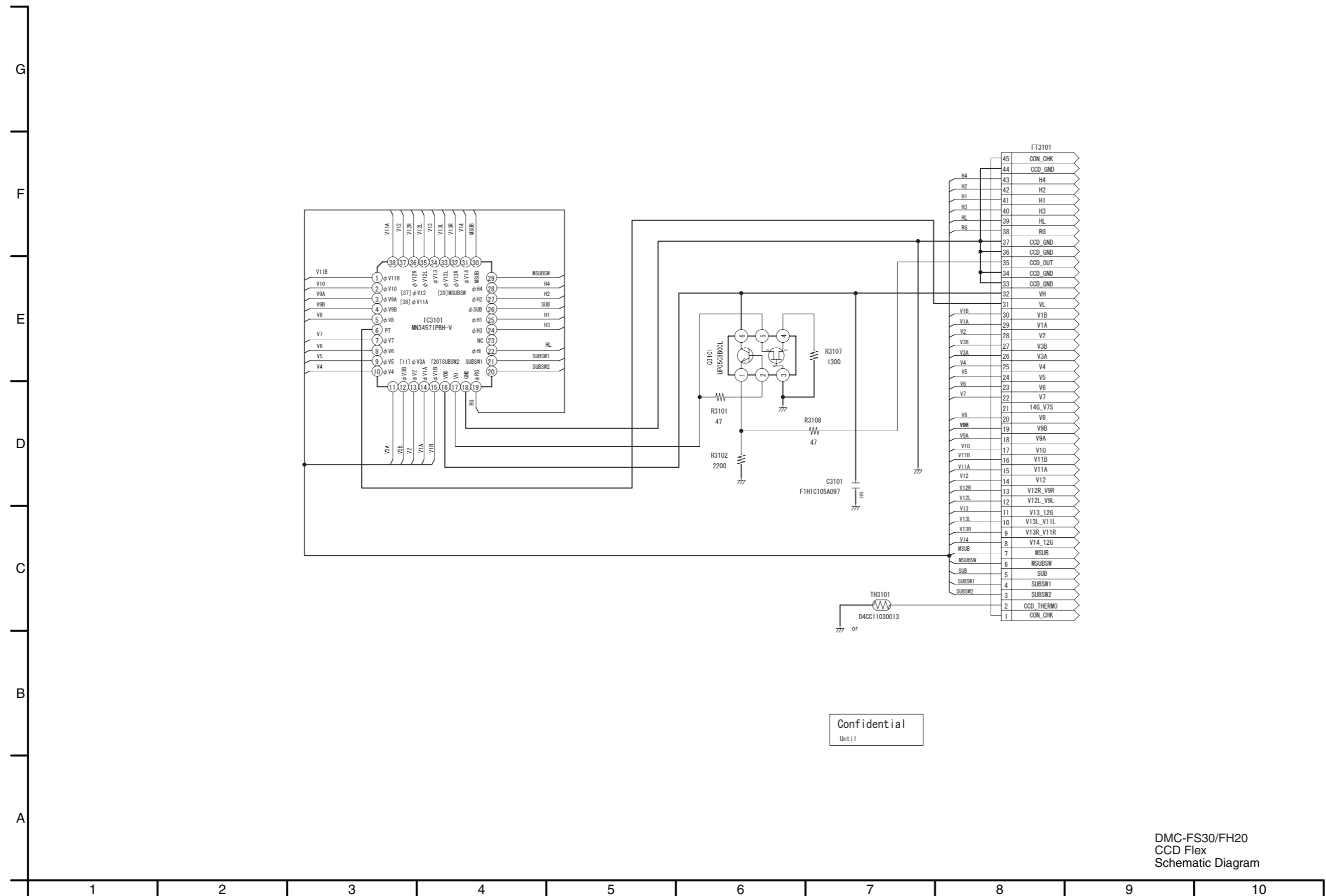

Confidential  
Until

# S4.4. Lens Flex Schematic Diagram

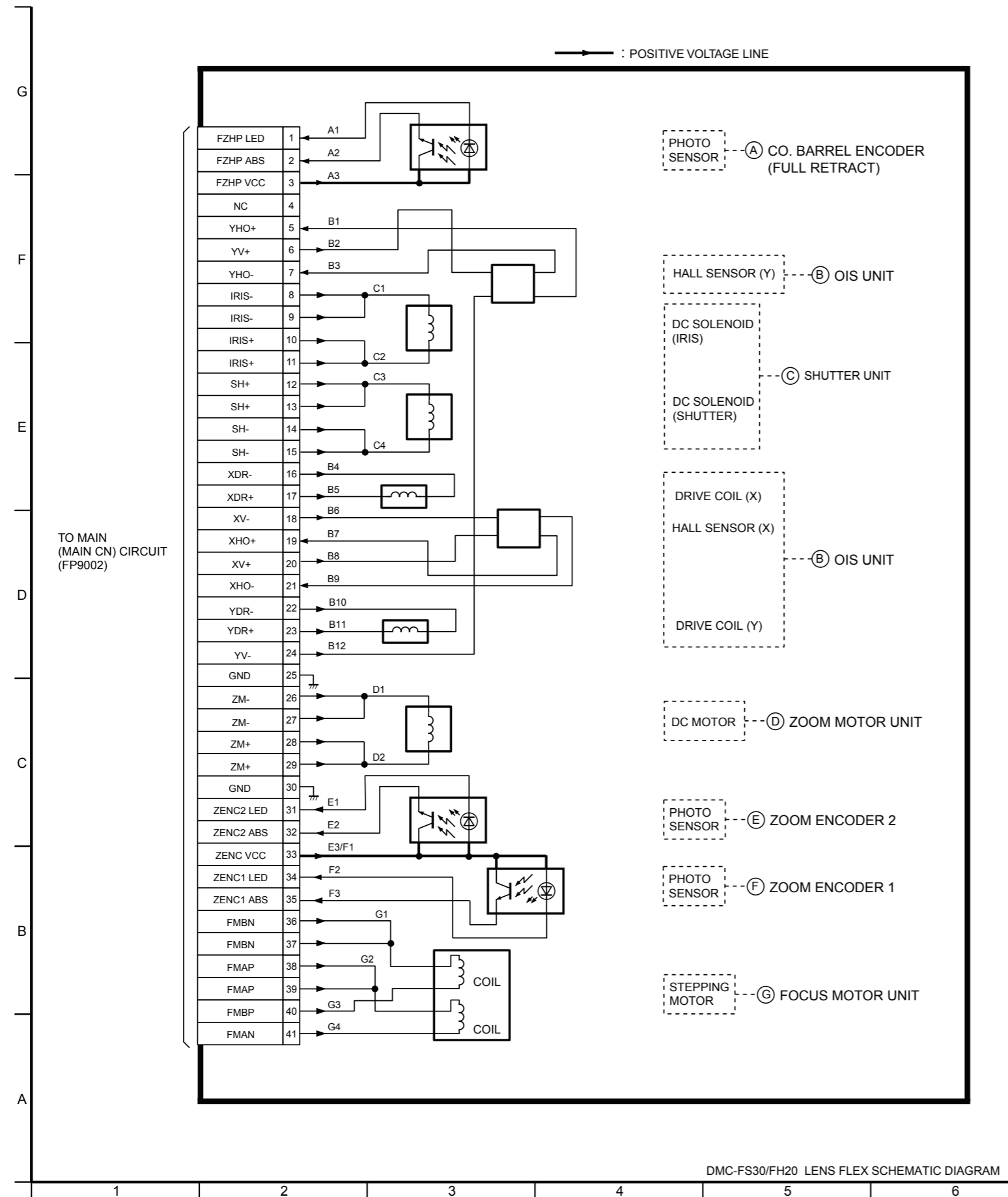

# S5. Print Circuit Board

## S5.1. Flash Top P.C.B.

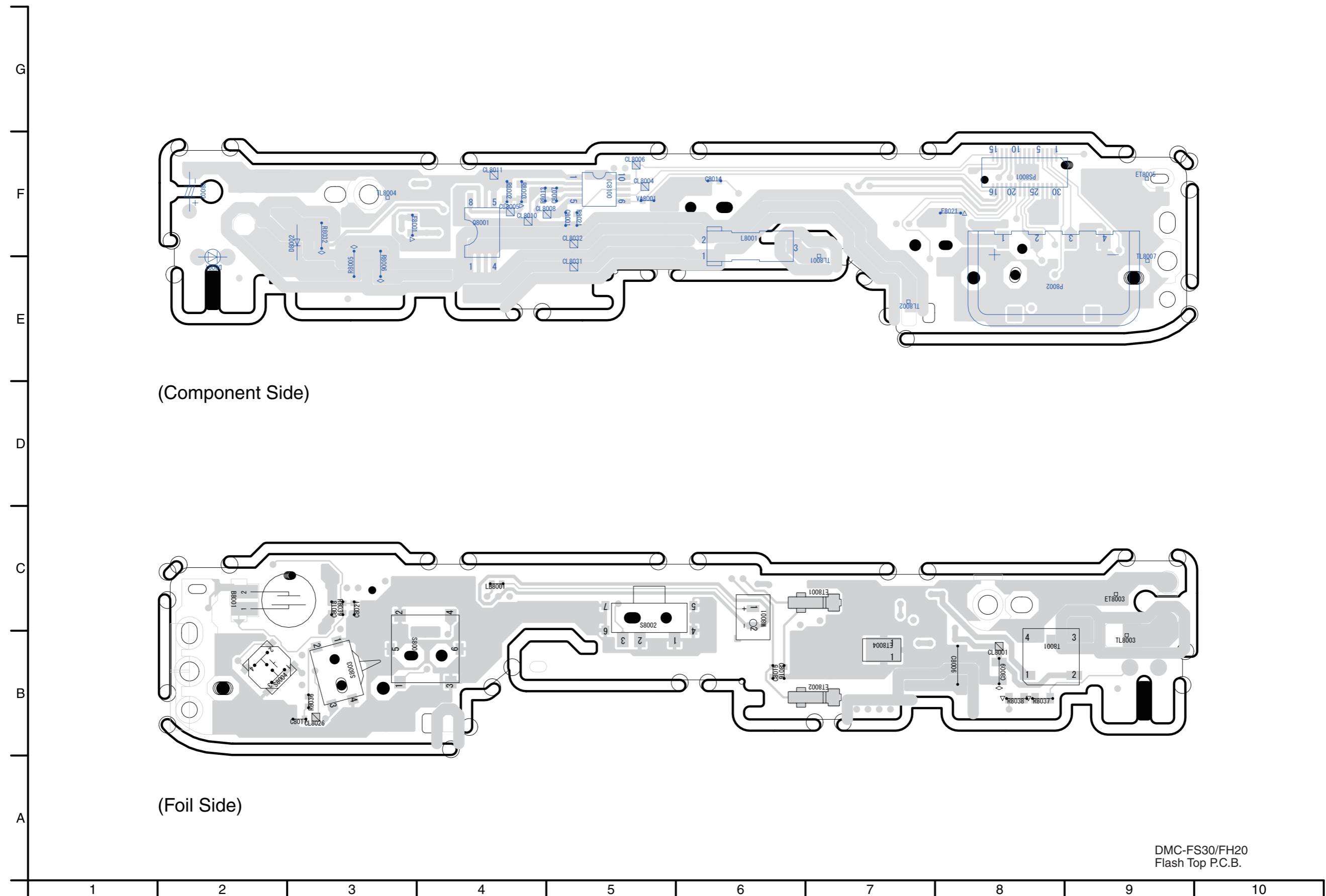

S5.2. CCD Flex P.C.B.

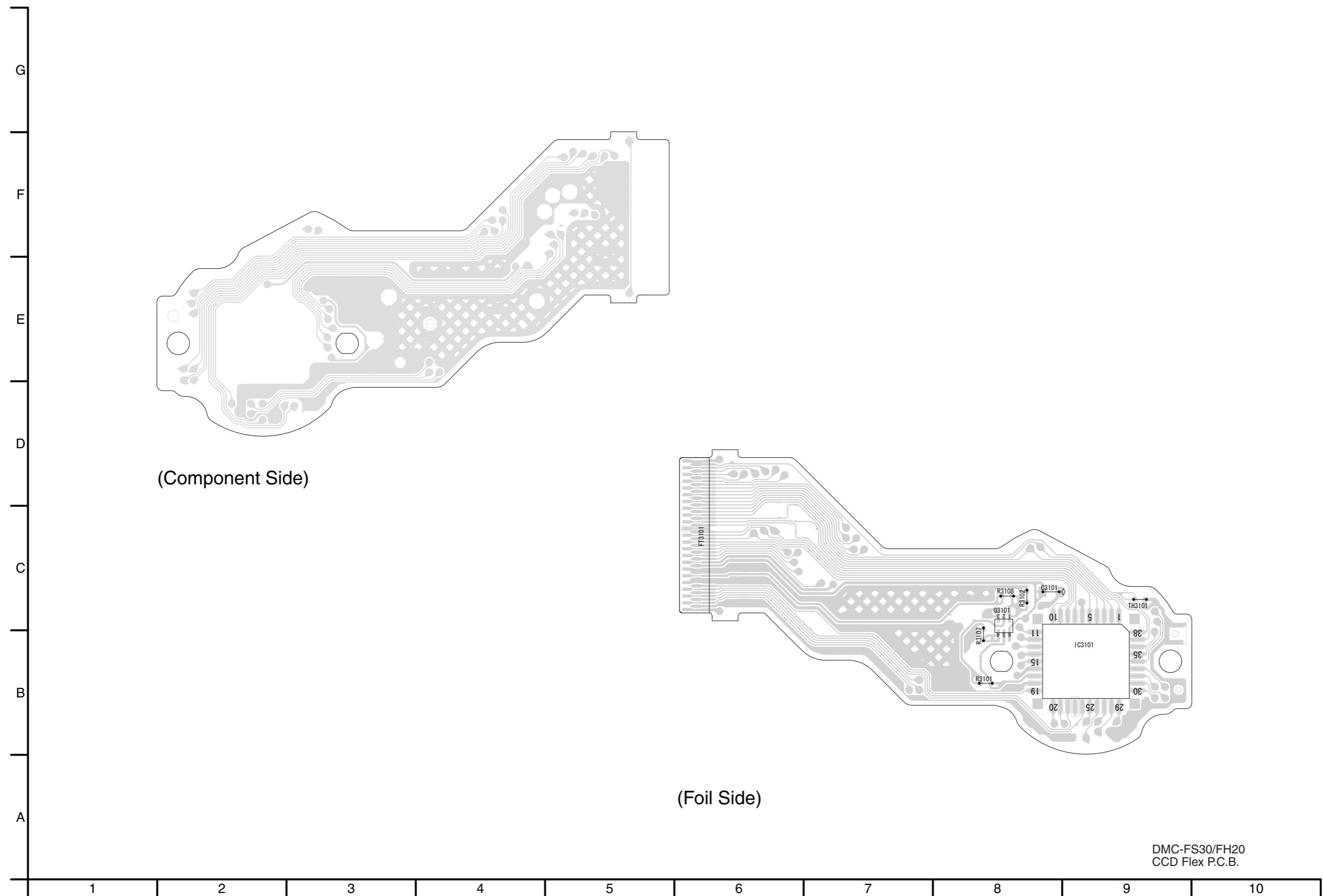

DMC-FS30/FH20  
CCD Flex P.C.B.

S5.3. Lens Flex P.C.B.

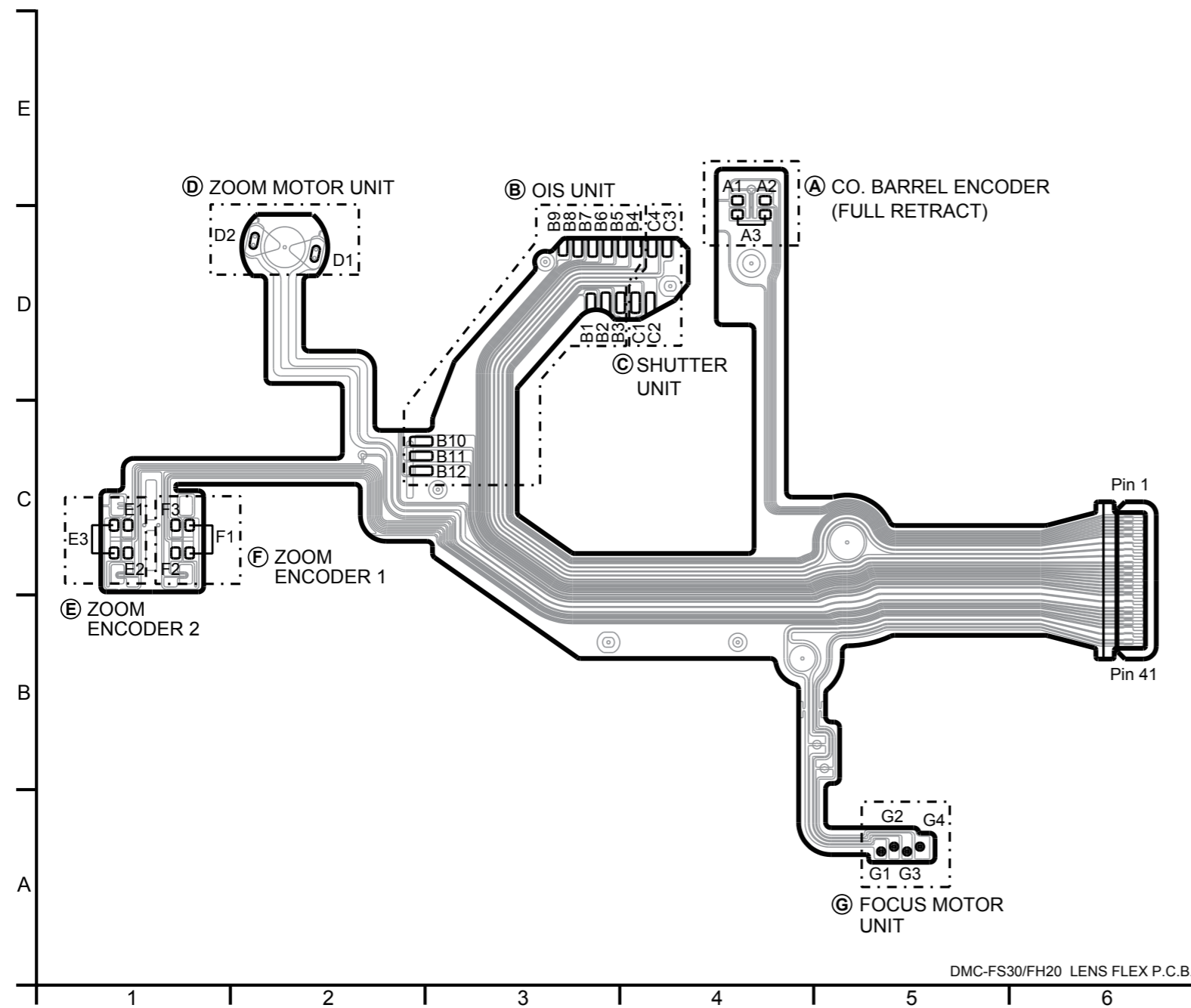

## S6. Replacement Parts List

- Note:
1. \* Be sure to make your orders of replacement parts according to this list.
  2. **IMPORTANT SAFETY NOTICE**  
Components identified with the mark  have the special characteristics for safety.  
When replacing any of these components, use only the same type.
  3. Unless otherwise specified,  
All resistors are in OHMS, K=1,000 OHMS. All capacitors are in MICRO-FARADS (uf), P=uuF.
  4. The marking (RTL) indicates the retention time is limited for this item. After the discontinuation of this assembly in production, it will no longer be available.
  5. Supply of CD-ROM, in accordance with license protection, is allowable as replacement parts only for customers who accidentally damaged or lost their own.

**E.S.D. standards for Electrostatically Sensitive Devices, refer to PREVENTION OF ELECTROSTATIC DISCHARGE (ESD) TO ELECTROSTATICALLY SENSITIVE (ES) DEVICES section.**

**Definition of Parts supplier:**

1. **Parts marked with [ENERGY] in the remarks column are supplied from Panasonic Corporation Energy Company.**
2. **Parts marked with [SPC] in the remarks column are supplied from AVC-CSC-SPC. Others are supplied from PAVCSG.**



Ref.No.	Part No.	Part Name & Description	Pcs	Remarks	Ref.No.	Part No.	Part Name & Description	Pcs	Remarks
##	VEP56098A	MAIN P.C.B.	1	(RTL) E.S.D.					
##	VEP59075A	SUB OPERATION P.C.B.	1	(RTL) E.S.D.					
##	VEP58107A	FLASH TOP P.C.B.	1	(RTL) E.S.D.					
##	VEK0Q32	CCD UNIT							
##	VEP58107A	FLASH TOP P.C.B.		(RTL) E.S.D.					
C8001	F1G0J105A022	C.CAPACITOR CH 6.3V 1U	1						
C8006	F1K2E4730005	C.CAPACITOR 250V 0.047U	1						
C8007	F1G1H150A565	C.CAPACITOR CH 50V 15P	1						
C8009	F1J0J106A020	C.CAPACITOR CH 6.3V 10U	1						
C8014	F1G1A1040006	C.CAPACITOR CH 10V 0.1U	1						
C8017	F1G0J1050007	C.CAPACITOR CH 6.3V 1U	1						
C8018	F1G0J1050007	C.CAPACITOR CH 6.3V 1U	1						
C8021	F1G0J1050007	C.CAPACITOR CH 6.3V 1U	1						
D8002	MA2YF8000L	DIODE	1	E.S.D.					
ET8001	K4AC01D00001	EARTH SPRING	1						
ET8002	K4AC01D00001	EARTH SPRING	1						
ET8004	N9ZZ00000333	EARTH SPRING	1						
△ F8001	ERBSE1R25U	FUSE 32V 1.25A	1						
△ F8021	ERBSE1R50U	FUSE 32V 1.5A	1						
IC8100	C0ZBZ0001710	IC	1	E.S.D.					
L8001	G5F1A0000026	CHIP COIL	1						
LB8001	J0JCC0000415	FILTER	1						
M8001	L0CBAA000014	MICROPHONE	1						
P8002	K4ZZ04000054	CONNECTOR 4P	1						
PS8001	K1KB30AA0123	CONNECTOR 30P	1						
Q8001	B1JBLP000022	TRANSISTOR	1	E.S.D.					
R8002	ERJ3GEYJ104V	M.RESISTOR CH 1/10W 100K	1						
R8003	ERJ3GEYJ620V	M.RESISTOR CH 1/10W 62	1						
R8005	ERJ6GEYJ514V	M.RESISTOR CH 1/10W 514K	1						
R8006	ERJ6GEYJ514V	M.RESISTOR CH 1/10W 514K	1						
R8013	ERJ2RHD2871X	M.RESISTOR CH 1/16W 2870	1						
R8021	ERJ2GEJ473X	M.RESISTOR CH 1/16W 47K	1						
R8032	D1BD8203A119	RESISTOR	1						
R8036	ERJ2GEJ103X	M.RESISTOR CH 1/10W 10K	1						
R8037	ERJ3GEYJ220V	M.RESISTOR CH 1/10W 22	1						
R8038	ERJ3GEYJ220V	M.RESISTOR CH 1/10W 22	1						
R8039	ERJ2GEJ512X	M.RESISTOR CH 1/16W 5.1K	1						
S8001	K0F212A00003	SWITCH	1						
S8002	K0D112B00145	SWITCH	1						
S8003	K0L1CB000003	SWITCH	1						
S8004	K0F111A00539	SWITCH	1						
T8001	G5D1A0000080	TRANSFORMER	1						
##	VEK0Q32	CCD UNIT							
C3101	F1H1C105A097	C.CAPACITOR CH 16V 1U	1	[SPC]					
Q3101	UP05C8B00L	TRANSISTOR	1	[SPC] E.S.D.					
R3101	ERJ2GEJ470	M.RESISTOR CH 1/16W 47	1	[SPC]					
R3102	ERJ2GEJ222	M.RESISTOR CH 1/10W 2.2K	1	[SPC]					
R3107	ERJ2GEJ132	M.RESISTOR CH 1/10W 1.3K	1	[SPC]					
R3108	ERJ2GEJ470	M.RESISTOR CH 1/16W 47	1	[SPC]					
TH3101	D4CC11030013	THERMISTOR	1	[SPC]					

Ref.No.	Part No.	Part Name & Description	Pcs	Remarks	Ref.No.	Part No.	Part Name & Description	Pcs	Remarks
1	VEP56098A	MAIN P.C.B.	1	(RTL) E.S.D.	112-1	L6HA64NC0020	FOCUS MOTOR UNIT	1	[SPC]
2	VEP58107A	FLASH TOP P.C.B.	1	(RTL) E.S.D.	112-2	VMB4333	FOCUS SPRING	1	[SPC]
3	VEP59075A	SUB OPERATION P.C.B.	1	(RTL) E.S.D.	112-3	VXP3358	4TH LENS FRAME UNIT	1	[SPC]
4	VYQ5639	MODE KNOB UNIT	1		113	VXP3355	DRIVE/PENETRATION FRAME UNIT	1	[SPC]
6	VMP9565	FRAME PLATE	1		114	VZT0938	TAPE A	1	[SPC]
7	L5EDDXM00008	LCD UNIT	1		115	VZT0938	TAPE A	1	[SPC]
8	VYK3S60	FRONT CASE UNIT	1	EGS, EPS, EBS, EES, PCS, PUS, GCS, GFS, GNS	116	VZT0939	TAPE B	1	[SPC]
8	VYK3S61	FRONT CASE UNIT	1	EKG, EPK, EFK, EBK, EEK, PCK, PUK, PRK, GCK, GFK, GTK, GNK, GDK	117	VZT0814	LENS TAPE	1	[SPC]
8	VYK3S62	FRONT CASE UNIT	1	PCR, PUR, PRR, GCR, GFR	118	VZT0814	LENS TAPE	1	[SPC]
8	VYK3S63	FRONT CASE UNIT	1	EGA, EPA, EFA, EBA, PUA, GCA, GFA, GNA	B1	VHD2081	SCREW	1	
8	VYK3S64	FRONT CASE UNIT	1	EGV, EPV, EFV, EBV, EEV, PUV, PRV, GCV, GTV, GNV, GDV	B2	VHD2081	SCREW	1	
8-1	VGK3602	LENS RING	1		B3	VHD2081	SCREW	1	
8	VYK3Z40	FRONT CASE UNIT	1	PS	B4	VHD2081	SCREW	1	(-S/A/R)
8	VYK3Z41	FRONT CASE UNIT	1	PK	B4	VHD2082	SCREW	1	(-K/V)
8	VYK3Z42	FRONT CASE UNIT	1	PR	B5	VHD2081	SCREW	1	(-S/A/R)
8	VYK3Z43	FRONT CASE UNIT	1	PA	B5	VHD2082	SCREW	1	(-K/V)
8	VYK3Z44	FRONT CASE UNIT	1	PV	B6	VHD2081	SCREW	1	(-S/A/R)
9	VYK3S65	BATTERY DOOR UNIT	1	(-S)	B6	VHD2082	SCREW	1	(-K/V)
9	VYK3S66	BATTERY DOOR UNIT	1	(-K)	B7	VHD2081	SCREW	1	(-S/A/R)
9	VYK3S68	BATTERY DOOR UNIT	1	(-A)	B7	VHD2082	SCREW	1	(-K/V)
9	VYK3S69	BATTERY DOOR UNIT	1	(-V)	B8	VHD1909	SCREW	1	
9	VYK3S67	BATTERY DOOR UNIT	1	(-R)	B9	VHD1909	SCREW	1	
9-1	VMB4143	BATTERY DOOR SPRING	1		B10	VHD1909	SCREW	1	
9-2	VMS7863	BATTERY DOOR SHAFT	1		B13	VHD2004	SCREW	1	
10	VYK3S70	REAR CASE UNIT	1	(-S)	B14	VHD2210	SCREW	1	
10	VYK3S71	REAR CASE UNIT	1	(-K)	B15	XQN16+BJ7FN	SCREW	1	
10	VYK3S73	REAR CASE UNIT	1	(-A)	B16	XQN16+BJ7FN	SCREW	1	
10	VYK3S74	REAR CASE UNIT	1	(-V)	B17	XQN16+BJ7FN	SCREW	1	
10	VYK3S72	REAR CASE UNIT	1	(-R)	B18	VHD1998	SCREW	1	
10-1	VGU0F45	CURSOR BUTTON	1		B19	VHD1998	SCREW	1	
11	B3ADA0000230	AF LED	1	E.S.D. (D8001)	B101	VHD1871	SCREW	1	[SPC]
12	EFN-AMAM2AZD	FLASH	1		B102	VHD1871	SCREW	1	[SPC]
⚠ 13	F2A2F8800003	E.CAPACITOR	1	(C8003)	B103	VHD1871	SCREW	1	[SPC]
14	L0AA01A00047	SPEAKER	1		B104	VHD2011	SCREW	1	[SPC]
⚠ 15	ML-421S/DN	BUTTON BATTERY	1	[ENERGY] (B8001)	B105	XQN14+BJ4FNK	SCREW	1	[SPC]
16	VGL1290	AF PANEL LIGHT	1		B106	XQN14+BJ4FNK	SCREW	1	[SPC]
17	VMB4278	C-EARTH SPRING	1	(ET8003)	B107	XQN14+BJ4FNK	SCREW	1	[SPC]
18	VMP9553	TOP PLATE	1	(ET8005)	B108	XQN14+BJ4FNK	SCREW	1	[SPC]
19	VMT1968	MIC DAMPER	1		B109	XQN14+BJ4FNK	SCREW	1	[SPC]
20	VMT2029	IRIS DAMPER	1		B110	XQN14+BJ4FNK	SCREW	1	[SPC]
21	VYK3S58	TOP CASE UNIT	1	(FS30)	B111	XQN14+BJ4FNK	SCREW	1	[SPC]
21	VYK3S56	TOP CASE UNIT	1	(FH20)					
21-1	VGQ0J75	POWER KNOB BASE	1						
21-2	VGU0F56	POWER KNOB	1						
21-3	VGU0F59	IA BUTTON	1						
22	VGK3603	SIDE ORNAMENT L	1						
23	VGK3604	SIDE ORNAMENT R	1						
24	VGQ9717	BATTERY LOCK KNOB	1						
25	VKF4645	JACK DOOR	1						
26	VMB4152	BATTERY LOCK SPRING	1						
27	VMB4337	BATTERY OUT SPRING	1						
28	VMP9240	TRIPOD	1						
29	VMP9564	FRAME	1						
30	VMP9566	BATTERY CASE	1						
31	VYP9302	LCD PANEL UNIT	1						
100	VXW1105	LENS UNIT(W/O CCD)	1	[SPC]					
102	VEK0Q32	CCD UNIT	1	[SPC] E.S.D.					
103	L6DA8DFC0002	ZOOM MOTOR	1	[SPC]					
104	VEK0P74	LENS FPC UNIT	1	[SPC]					
104-1	B3NBA0000011	PHOTO SENSOR	1	[SPC]					
104-2	B3NBA0000011	PHOTO SENSOR	1	[SPC]					
104-3	B3NBA0000011	PHOTO SENSOR	1	[SPC]					
105	VDW1958	BOTH SIDES CAM FRAME	1	[SPC]					
106	VDW1962	2ND 3RD DIRECT FRAME	1	[SPC]					
107	VXP3345	1ST LENS FRAME UNIT	1	[SPC]					
108	VXP3348	1ST DIRECT FRAME UNIT	1	[SPC]					
109	VXP3349	2ND LENS FRAME UNIT	1	[SPC]					
110	VXP3350	3RD LENS FRAME UNIT	1	[SPC]					
111	VXQ1831	FIX FRAME UNIT	1	[SPC]					
112	VXQ1832	MASTER FLANGE UNIT	1	[SPC]					



Ref.No.	Part No.	Part Name & Description	Pcs	Remarks	Ref.No.	Part No.	Part Name & Description	Pcs	Remarks
300	VPF1372	CAMERA BAG	1	(EXCEPT P,PC,PU)	314	VPK4227	PACKING CASE	1	EGS,EPS,EBS,EES
△ 301	DE-A60AA/SX	BATTERY CHARGER	1	EG,EP,EF,EB,GN	314	VPK4233	PACKING CASE	1	EGK,EPK,EFK,EBK,EEK
△ 301	DE-A60BB/SX	BATTERY CHARGER	1	EE,GC,GF,GD	314	VPK4241	PACKING CASE	1	EGA,EPA,EFA,EBA
△ 301	DE-A60DA/SX	BATTERY CHARGER	1	PR	314	VPK4247	PACKING CASE	1	EGV,EPV,EFV,EBV,EEV
△ 301	DE-A60CA/SX	BATTERY CHARGER	1	GT	314	VPK4232	PACKING CASE	1	PRK,GCK,GTK,GNK,GDK
△ 302	-----	BATTERY	1	(EXCEPT P,PC,PU)	314	VPK4237	PACKING CASE	1	PRR,GCR
304	K1HA08AD0001	USB CABLE W/PLUG	1	(EXCEPT P,PC,PU)	314	VPK4246	PACKING CASE	1	PRV,GCV,GTV,GNV,GDV
305	K1HA08CD0027	AV CABLE W/PLUG	1	(EXCEPT P,PC,PU)	314	VPK4228	PACKING CASE	1	GCS,GNS
306	VFC4297-B	HAND STRAP	1	(EXCEPT P,PC,PU)	314	VPK4242	PACKING CASE	1	GCA,GNA
308	VGQ0D56	BATTERY PROTECTION CASE	1	(EXCEPT P,PC,PU)	314	VPK4229	PACKING CASE	1	GFS
310	VPF1378	BAG, POLYETHYLENE	1	(EXCEPT P,PC,PU)	314	VPK4234	PACKING CASE	1	GFK
△ 311	VFF0555-S	CD-ROM (INSTRUCTION BOOK)	1	EG,EP,EF,EB [SPC] See "Notes"	314	VPK4238	PACKING CASE	1	GFR
△ 311	VFF0556-S	CD-ROM (INSTRUCTION BOOK)	1	EE [SPC] See "Notes"	314	VPK4243	PACKING CASE	1	GFA
△ 311	VFF0557-S	CD-ROM (INSTRUCTION BOOK)	1	GC,GF,GT,GN,GD [SPC] See "Notes"	315	VPN6982	CUSHION	1	(EXCEPT P,PC,PU)
△ 311	VFF0554-S	CD-ROM (INSTRUCTION BOOK)	1	PR [SPC] See "Notes"	318	VQL2C68-A	OPERATING LABEL	1	GT
△ 312	VQT2K54	SIMPLIFIED O/I (GERMAN/FRENCH)	1	EG	△ 319	K2CT39A00002	AC CORD W/PLUG	1	EB,GC
△ 312	VQT2K55	SIMPLIFIED O/I (ITALIAN/DUTCH)	1	EG	△ 320	K2CQ29A00002	AC CORD W/PLUG	1	EG,EP,EF,EE,GF
△ 312	VQT2K56	SIMPLIFIED O/I (SPANISH/PORTUGUESE)	1	EG	△ 320	K2CR29A00001	AC CORD W/PLUG	1	GD
△ 312	VQT2K57	SIMPLIFIED O/I (TURKISH)	1	EG	△ 321	K2CJ29A00002	AC CORD W/PLUG	1	GN
△ 312	VQT2K58	SIMPLIFIED O/I (SWEDISH/DANISH)	1	EP	△ 322	K2CA29A00021	AC CORD W/PLUG	1	GT
△ 312	VQT2K59	SIMPLIFIED O/I (POLISH/CZECH)	1	EP	△ 324	K2CJ29A00003	AC CORD W/PLUG	1	PR
△ 312	VQT2K60	SIMPLIFIED O/I (HUNGARIAN/FINNISH)	1	EP					
△ 312	VQT2K61	SIMPLIFIED O/I (FRENCH)	1	EF					
△ 312	VQT2K62	SIMPLIFIED O/I (ENGLISH)	1	EB					
△ 312	VQT2K63	SIMPLIFIED O/I (RUSSIAN/UKRAINIAN)	1	EE					
△ 312	VQT2K53	SIMPLIFIED O/I (SPANISH)	1	PR					
△ 312	VQT2K64	SIMPLIFIED O/I (ENGLISH/ CHINESE(TRADITIONAL))	1	GC,GF					
△ 312	VQT2K65	SIMPLIFIED O/I (ARABIC/PERSIAN)	1	GC,GF					
△ 312	VQT2K66	SIMPLIFIED O/I (CHINESE(TRADITIONAL))	1	GT					
△ 312	VQT2K68	SIMPLIFIED O/I (ENGLISH)	1	GN					
△ 312	VQT2K69	SIMPLIFIED O/I (KOREAN)	1	GD					
313	VQT2K39	O/I SOFTWARE (GERMAN/FRENCH/ITALIAN/ DUTCH/SPANISH/PORTUGUESE/ TURKISH)	1	EG					
313	VQT2K40	O/I SOFTWARE (FINNISH/SWEDISH/DANISH/ POLISH/CZECH/HUNGARIAN)	1	EP					
313	VQT2K41	O/I SOFTWARE (FRENCH)	1	EF					
313	VQT2K42	O/I SOFTWARE (ENGLISH)	1	EB,GN					
313	VQT2K43	O/I SOFTWARE (RUSSIAN/UKRAINIAN)	1	EE					
313	VQT2K44	O/I SOFTWARE (ENGLISH/ CHINESE(TRADITIONAL)/ ARABIC/PERSIAN)	1	GC,GF					
313	VQT2K45	O/I SOFTWARE (CHINESE(TRADITIONAL))	1	GT					
313	VQT2K47	O/I SOFTWARE (KOREAN)	1	GD					
313	VQT2K38	O/I SOFTWARE (SPANISH/PORTUGUESE)	1	PR					



## S7.2. Packing Parts and Accessories Section (1)

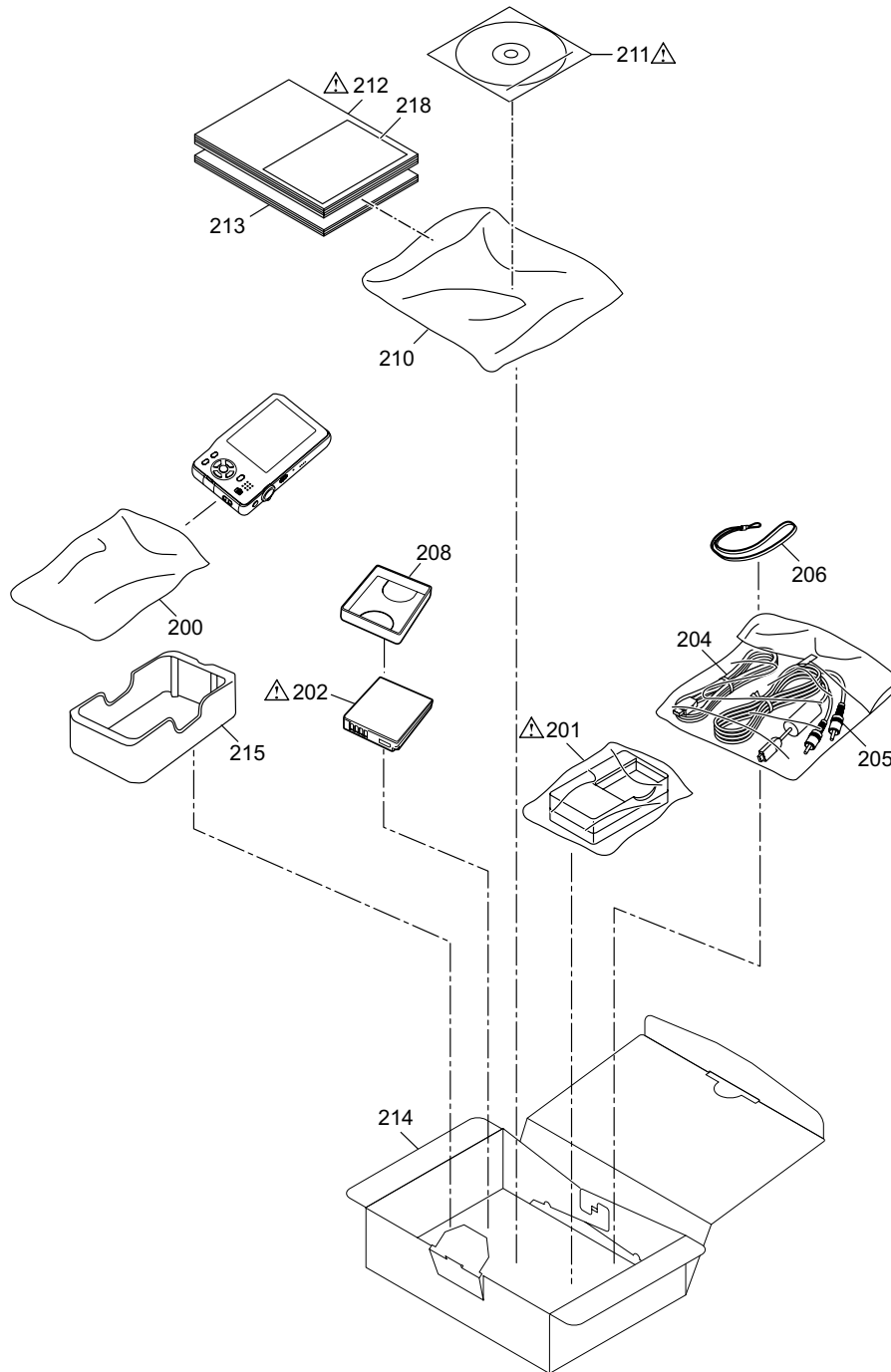

### S7.3. Packing Parts and Accessories Section (2)

