

# Service Manual

DVD Video Camcorder

LEICA DICOMAR

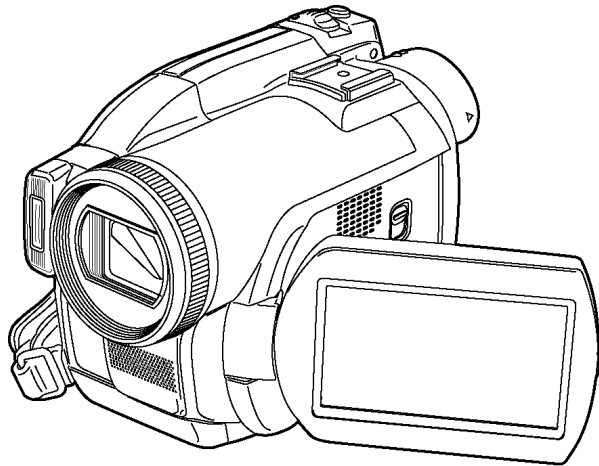

- VDR-D300EG
- VDR-D300E
- VDR-D300EB
- VDR-D300EP
- VDR-D300EE
- VDR-D300GC
- VDR-D300GN
- VDR-D300SG
- VDR-D300GCS
- VDR-D308GK

VOL.1

Colour

(S).....Silver Type

# CONTENTS

	Page		Page
<b>1 Safety Precaution</b> .....	<b>3</b>	10.1. Cleaning Lens, Viewfinder and LCD Panel .....	47
1.1. General Guidelines .....	3	10.2. Cleaning Disc .....	47
<b>2 Warning</b> .....	<b>4</b>	10.3. Cleaning optical pickup .....	47
2.1. Prevention of Electro Static Discharge (ESD) to Electrostatically Sensitive (ES) Devices .....	4	<b>11 Schematic Diagrams</b> .....	<b>49</b>
2.2. Service caution based on legal restrictions .....	5	11.1. OVERALL SCHEMATIC DIAGRAM .....	49
2.3. Caution for AC Cord (RJA0053-3X type) .....	6	11.2. INTERCONNECTION SCHEMATIC DIAGRAM .....	50
2.4. How to Replace the Lithium Battery (PROCEDURE) .....	7	11.3. FLASH SCHEMATIC DIAGRAM .....	52
<b>3 Service Navigation</b> .....	<b>8</b>	11.4. FRONT SCHEMATIC DIAGRAM .....	53
3.1. Service Information .....	8	11.5. SIDE R SCHEMATIC DIAGRAM .....	54
3.2. Service Caution .....	9	11.6. MONITOR SCHEMATIC DIAGRAM .....	55
3.3. Procedure for Removing Disc .....	10	11.7. JACK SCHEMATIC DIAGRAM .....	56
<b>4 Specifications</b> .....	<b>11</b>	11.8. EVF SCHEMATIC DIAGRAM .....	56
<b>5 Location of Controls and Components</b> .....	<b>12</b>	11.9. EVF FPC SCHEMATIC DIAGRAM .....	56
<b>6 Service Mode</b> .....	<b>23</b>	11.10. DVD DRIVE FPC SCHEMATIC DIAGRAM .....	57
6.1. Error Display .....	23	11.11. DISK COVER LOCK UNIT SCHEMATIC DIAGRAM .....	57
6.2. Service Menu .....	24	11.12. SIDE L UNIT SCHEMATIC DIAGRAM .....	57
6.3. Firmware Version Check .....	26	11.13. REAR CASE UNIT SCHEMATIC DIAGRAM .....	58
<b>7 Service Fixture &amp; Tools</b> .....	<b>27</b>	11.14. FRONT FPC SCHEMATIC DIAGRAM .....	58
7.1. Service Tools and Equipment .....	27	11.15. SIDE R FPC SCHEMATIC DIAGRAM .....	58
<b>8 Disassembly and Assembly Instructions</b> .....	<b>28</b>	11.16. MONITOR FPC SCHEMATIC DIAGRAM .....	58
8.1. Disassembly Flow Chart .....	28	11.17. 3CCD FPC SCHEMATIC DIAGRAM .....	59
8.2. P.C.B. Layout .....	29	<b>12 Printed Circuit Board</b> .....	<b>61</b>
8.3. Disassembly Procedures .....	30	12.1. FLASH P.C.B. ....	61
8.4. Disassembly Procedures of Camera Lens Unit .....	39	12.2. FRONT P.C.B. ....	62
<b>9 Measurements and Adjustments</b> .....	<b>40</b>	12.3. JACK P.C.B. ....	63
9.1. Service Positions .....	40	12.4. EVF P.C.B. ....	63
9.2. Location for Connectors of the Main P.C.B. & Sub P.C.B. .....	42	12.5. SIDE R P.C.B. ....	64
9.3. Electrical Adjustment Procedures .....	44	12.6. MONITOR P.C.B. ....	65
<b>10 Maintenance</b> .....	<b>47</b>	<b>13 Parts and Exploded Views</b> .....	<b>67</b>
		13.1. EXPLODED VIEWS .....	67
		13.2. REPLACEMENT PARTS LIST .....	73

# 1 Safety Precaution

## 1.1. General Guidelines

### 1. IMPORTANT SAFETY NOTICE

There are special components used in this equipment which are important for safety. These parts are marked by in the Schematic Diagrams, Circuit Board Layout, Exploded Views and Replacement Parts List. It is essential that these critical parts should be replaced with manufacturer's specified parts to prevent X-RADIATION, shock fire, or other hazards. Do not modify the original design without permission of manufacturer.

2. An Isolation Transformer should always be used during the servicing of AC Adaptor whose chassis is not isolated from the AC power line. Use a transformer of adequate power rating as this protects the technician from accidents resulting in personal injury from electrical shocks. It will also protect AC Adaptor from being damaged by accidental shorting that may occur during servicing.
3. When servicing, observe the original lead dress. If a short circuit is found, replace all parts which have been overheated or damaged by the short circuit.
4. After servicing, see to it that all the protective devices such as insulation barriers, insulation papers shields are properly installed.
5. After servicing, make the following leakage current checks to prevent the customer from being exposed to shock hazards.

## 2 Warning

### 2.1. Prevention of Electro Static Discharge (ESD) to Electrostatically Sensitive (ES) Devices

Some semiconductor (solid state) devices can be damaged easily by static electricity. Such components commonly are called Electrostatically Sensitive (ES) Devices. Examples of typical ES devices are integrated circuits and some field-effect transistors and semiconductor “chip” components. The following techniques should be used to help reduce the incidence of component damage caused by electro static discharge (ESD).

1. Immediately before handling any semiconductor component or semiconductor-equipped assembly, drain off any ESD on your body by touching a known earth ground. Alternatively, obtain and wear a commercially available discharging ESD wrist strap, which should be removed for potential shock reasons prior to applying power to the unit under test.
2. After removing an electrical assembly equipped with ES devices, place the assembly on a conductive surface such as aluminum foil, to prevent electrostatic charge buildup or exposure of the assembly.
3. Use only a grounded-tip soldering iron to solder or unsolder ES devices.
4. Use only an antistatic solder removal device. Some solder removal devices not classified as “antistatic (ESD protected)” can generate electrical charge sufficient to damage ES devices.
5. Do not use freon-propelled chemicals. These can generate electrical charges sufficient to damage ES devices.
6. Do not remove a replacement ES device from its protective package until immediately before you are ready to install it. (Most replacement ES devices are packaged with leads electrically shorted together by conductive foam, aluminum foil or comparable conductive material).
7. Immediately before removing the protective material from the leads of a replacement ES device, touch the protective material to the chassis or circuit assembly into which the device will be installed.

**CAUTION:**

Be sure no power is applied to the chassis or circuit, and observe all other safety precautions.

8. Minimize bodily motions when handling unpackaged replacement ES devices. (Otherwise harmless motion such as the brushing together of your clothes fabric or the lifting of your foot from a carpeted floor can generate static electricity (ESD) sufficient to damage an ES device).

#### IMPORTANT SAFETY NOTICE

There are special components used in this equipment which are important for safety. These parts are marked by  in the schematic diagrams, Exploded Views and replacement parts list. It is essential that these critical parts should be replaced with manufacturer's specified parts to prevent shock, fire, or other hazards. Do not modify the original design without permission of manufacturer.

## 2.2. Service caution based on legal restrictions

### 2.2.1. General description about Lead Free Solder (PbF)

The lead free solder has been used in the mounting process of all electrical components on the printed circuit boards used for this equipment in considering the globally environmental conservation.

The normal solder is the alloy of tin (Sn) and lead (Pb). On the other hand, the lead free solder is the alloy mainly consists of tin (Sn), silver (Ag) and Copper (Cu), and the melting point of the lead free solder is higher approx.30 degrees C (86°F) more than that of the normal solder.

#### Definition of PCB Lead Free Solder being used

The letter of "PbF" is printed either foil side or components side on the PCB using the lead free solder. (See right figure)	<b>PbF</b>
---	------------

#### Service caution for repair work using Lead Free Solder (PbF)

- The lead free solder has to be used when repairing the equipment for which the lead free solder is used.  
(Definition: The letter of "PbF" is printed on the PCB using the lead free solder.)
- To put lead free solder, it should be well molten and mixed with the original lead free solder.
- Remove the remaining lead free solder on the PCB cleanly for soldering of the new IC.
- Since the melting point of the lead free solder is higher than that of the normal lead solder, it takes the longer time to melt the lead free solder.
- Use the soldering iron (more than 70W) equipped with the temperature control after setting the temperature at 350±30 degrees C (662±86°F).

#### Recommended Lead Free Solder (Service Parts Route.)

- The following 3 types of lead free solder are available through the service parts route.  
RFKZ03D01K----- (0.3mm 100g Reel)  
RFKZ06D01K----- (0.6mm 100g Reel)  
RFKZ10D01K----- (1.0mm 100g Reel)

#### Note

\* Ingredient: tin (Sn), 96.5%, silver (Ag) 3.0%, Copper (Cu) 0.5%, Cobalt (Co) / Germanium (Ge) 0.1 to 0.3%

## 2.3. Caution for AC Cord (RJA0053-3X type)

### 2.3.1. Information for your safety

#### IMPORTANT

Your attention is drawn to the fact that recording of pre-recorded tapes or discs or other published or broadcast material may infringe copyright laws.

#### WARNING

To reduce the risk of fire or shock hazard, do not expose this equipment to rain or moisture.

#### CAUTION

To reduce the risk of fire or shock hazard and annoying interference, use the recommended accessories only.

#### FOR YOUR SAFETY

##### DO NOT REMOVE THE OUTER COVER

To prevent electric shock, do not remove the cover. No user serviceable parts inside. Refer servicing to qualified service personnel.

### 2.3.2. Caution for AC mains lead

For your safety, please read the following text carefully.

This appliance is supplied with a moulded three-pin mains plug for your safety and convenience.

A 5-ampere fuse is fitted in this plug.

Should the fuse need to be replaced please ensure that the replacement fuse has a rating of 5 amperes and it is approved by ASTA or BSI to BS1362

Check for the ASRA mark or the BSI mark on the body of the fuse.



If the plug contains a removable fuse cover you must ensure that it is refitted when the fuse is replaced.

If you lose the fuse cover, the plug must not be used until a replacement cover is obtained.

A replacement fuse cover can be purchased from your local Panasonic Dealer.

If the fitted moulded plug is unsuitable for the socket outlet in your home then the fuse should be removed and the plug cut off and disposed of safely.

There is a danger of severe electrical shock if the cut off plug is inserted into any 13-ampere socket.

If a new plug is to be fitted please observe the wiring code as shown below.

If in any doubt, please consult a qualified electrician.

#### 2.3.2.1. Important

The wires in this mains lead are coloured in accordance with the following code:

Blue	Neutral
Brown	Live

As the colours of the wires in the mains lead of this appliance may not correspond with the coloured markings identifying the terminals in your plug, proceed as follows:

The wire which is coloured BLUE must be connected to the terminal in the plug which is marked with the letter N or coloured BLACK.

The wire which is coloured BROWN must be connected to the terminal in the plug which is marked with the letter L or coloured RED.

Under no circumstances should either of these wires be connected to the earth terminal of the three pin plug, marked with the letter E or the Earth Symbol.

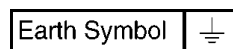

#### 2.3.2.2. Before use

remove the Connector Cover as follows.

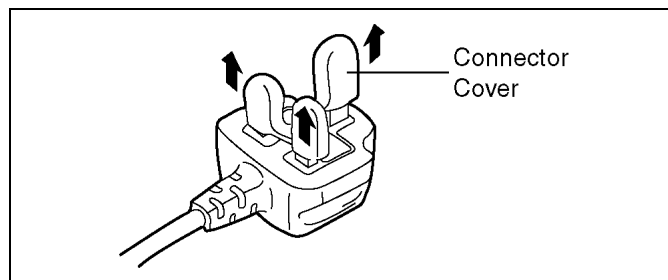

#### 2.3.2.3. How to replace the Fuse

1. Remove the Fuse Cover with a screwdriver.

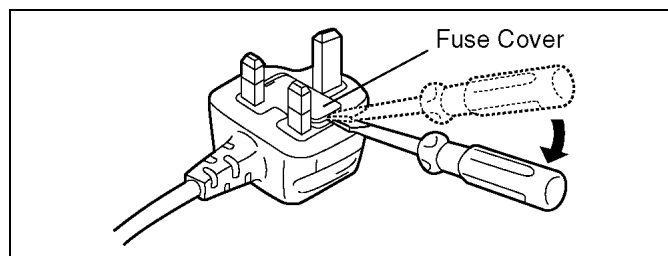

2. Replace the fuse and attach the Fuse cover.

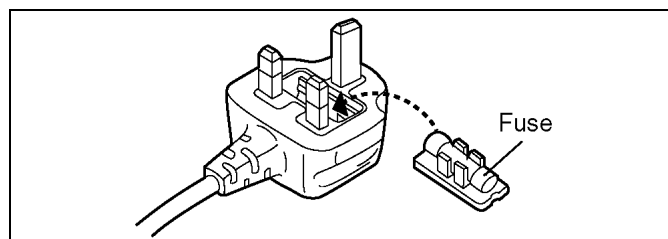

## 2.4. How to Replace the Lithium Battery (PROCEDURE)

1. Remove the Side (L) P.C.B.. (Refer to Disassembly Procedures.)
2. Unsolder the Lithium Battery "ML-614R/F9AT" and then replace the new one. (See Figure B1.)
3. Danger of explosion if battery is incorrectly replaced. Replace only with the same or equivalent type.

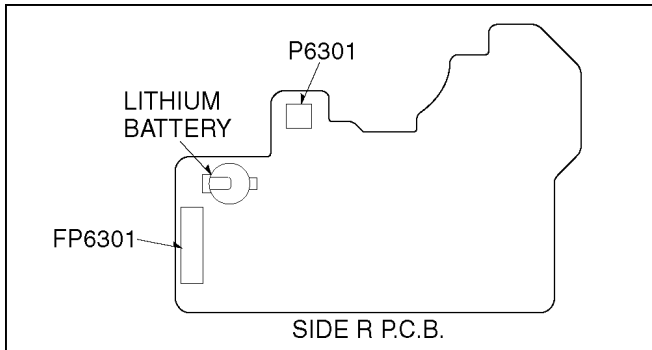

### CAUTION

The battery used in this device may present a risk of fire or chemical burn if mistreated.  
Do not recharge, disassemble, heat above 100 C (212 F), or incinerate.  
Replace battery with Panasonic part number ML-614R/F9AT only.  
Use of another battery may present a risk of fire or explosion.  
Dispose of used battery promptly.  
Keep away from children.  
Do not disassemble and do not dispose of in fire.

Fig. B1

### Note:

The lithium battery is a critical component. (Type No.: ML-614R/F9AT Manufactured by Panasonic.)  
It must never be subjected to excessive heat or discharge.  
It must therefore only be fitted in equipment designed specifically for its use.  
Replacement batteries must be of the same type and manufacture.  
They must be fitted in the same manner and location as the original battery, with the correct polarity contacts observed.  
Do not attempt to re-charge the old battery or re-use it for any other purpose.  
It should be disposed of in waste products destined for burial rather than incineration.

### CAUTION

Danger of explosion if battery is incorrectly replaced.  
Replace only with the same or equivalent type recommended by the equipment manufacturer.  
Discard used batteries according to manufacturer's instructions.

### PRECAUTION

Le fait de remplacer incorrectement la pile peut présenter des risques d'explosion.  
Remplacer la pile uniquement par une pile identique ou de type équivalent recommandée par le fabricant. Se débarrasser des piles usagées conformément aux instructions du fabricant.

### VORSICHT

Bei einer falsch eingesetzten Batterie besteht Explosionsgefahr. Nur mit einer vom Hersteller empfohlenen Batterie vom gleichen Typ ersetzen.  
Verbrauchte Batterien beim Fachhändler oder einer Sammelstelle für Sonderstoffe abliefern.

### VARNING

Explosionsfara vid felaktigt batteritype.  
Använd samma batterityp eller en ekvivalent typ som rekommenderas av apparattillverkaren.  
Kassera använt batteri enligt fabrikantens instruktion.

### ADVARSEL!

Lithiumbatteri-Eksplosionsfare ved fejlagtig håndtering.  
Udskiftning må kun ske med batteri af samme fabrikat og type.  
Levér det brugte batteri tilbage til leverandøren.

### VAROITUS

Paristo voi räjähtää, jos se on virheellisesti asennettu.  
Vaihda paristo ainoastaan laitevalmistajan suosittelemaan tyyppiin.  
Hävitä käytetty paristo valmistajan ohjeiden mukaisesti.

## 3 Service Navigation

### 3.1. Service Information

This service manual contains technical information which will allow service personnel's to understand and service this model.

Please place orders using the parts list and not the drawing reference numbers.

If the circuit is changed or modified, this information will be followed by supplement service manual to be filed with original service manual.

**Note 1:**

These movie camera uses AC Adaptor is DE-974GB or DE-974HA.

**Note 2:**

1) This service manual does not contain the following information, because of the impossibility of servicing at component level.

1. Schematic Diagram, Block Diagram and P.C.B. layout of Main P.C.B./Sub P.C.B.
2. Parts List for individual parts of Main P.C.B./Sub P.C.B.

2) The following category are recycle module part. Please send them to Central Repair Center.

\*Main P.C.B.

(LSEP8342P1FZ: VDR-D300EG/E/EB/EP, LSEP8342Q1FZ: VDR-D300EE/GC/GN/SG/GCS, D308GK)

\*Sub P.C.B.

(VEP23648C)

When a part replacement is required for repairing each Main P.C.B. and/or Sub P.C.B., replace the assembly parts.

(Main P.C.B. and/or Sub P.C.B.)

The following circuits are contained in Main P.C.B.

1. Main Connection Circuit
2. AVIO Circuit
3. Video Circuit
4. Memory Circuit
5. Mic AMP Circuit
6. LCD Circuit
7. Power Circuit

The following circuit is contained in Sub P.C.B..

1. Sub Connection Circuit
2. Camera Circuit
3. Lens Drive Circuit
4. Gyro AMP Circuit
5. System Control Circuit
6. Sub Power Circuit



## 3.2. Service Caution

### 3.2.1. How to Discharge the Capacitor on the Front P.C.B.

Remove the Flash P.C.B.. (Refer to Disassembly Procedures.)

#### CAUTION

Be sure to discharge the capacitor on Flash P.C.B. before disassembling.

#### CAUTION

Be careful of the high voltage circuit on Flash P.C.B. when servicing.

#### Method:

1. Prepare the 2 Resistors (ERG2SJ221:220 ohm/2w) for discharge.

#### Note:

1. Above 2 Resistors may be substituted with equivalent type.
2. Make short circuit using 2 Resistors between C6607(+) and C6607(-) for 3 seconds as follows.
3. After discharging, confirm that the capacitor voltage is sufficiently lowered using a voltmeter

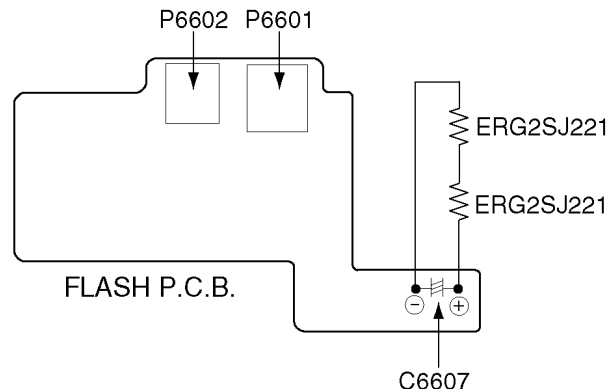

### 3.2.2. Precaution of Laser Light

Please remove the AC adapter/charger or battery at servicing that open the Disk Cover.

#### CAUTION

Laser light striking the eye may cause your eyesight to be lost : For safety, be sure to remove any power supply (AC adaptor/charger, battery, etc.) from the DVD video camera/recorder before starting work.

#### <CSA requirement>

CAUTION: VISIBLE LASER RADIATION DO NOT STARE INTO THE BEAM OR VIEW DIRECTLY WITH OPTICAL INSTRUMENTS CLASS 2M

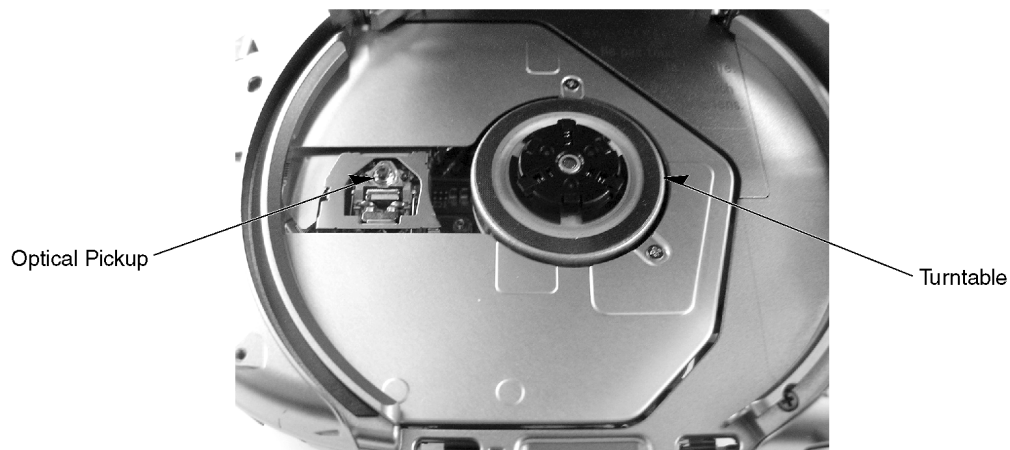

### 3.3. Procedure for Removing Disc

#### 3.3.1. Item to be checked

Connect the AC adapter/charger or charged battery (power supply), make sure that the ACCESS indicator turns off, and then press the DISC EJECT button again.

Even with normal product, the disc cannot be removed while the ACCESS indicator is lit or blinking.

#### 3.3.2. Procedure for Removing the disc manually

Please removing the disc by the following procedure when the disc cannot be removing due to the breakdown of the electrical system etc.

1. Remove the 3 Screws (A), and remove the Shoe Plate.
2. Remove the 1 Screw (B).
3. Release the 3 Tabs, and remove the Shoe Base.
4. Slide the Lock Lever to open the Disc Cover.
5. Remove the disc.

#### CAUTION



Laser light striking the eye may cause your eyesight to be lost : For safety, be sure to remove any power supply (AC adaptor/charger, battery, etc.) from the DVD video camera/recorder before starting work.

<CSA requirement>

CAUTION: VISIBLE LASER RADIATION DO NOT STARE INTO THE BEAM OR VIEW DIRECTLY WITH OPTICAL INSTRUMENTS CLASS 2M

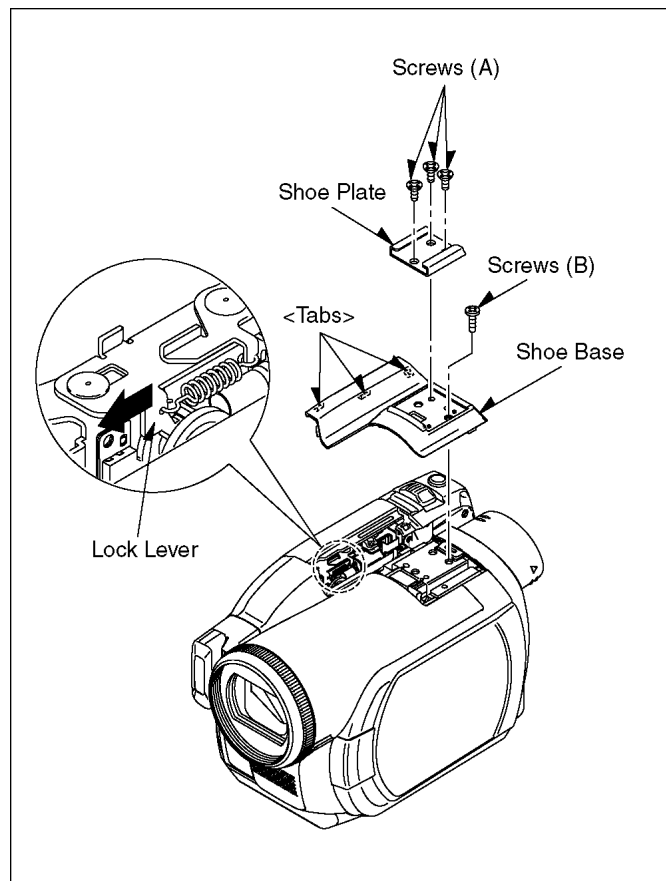

# 4 Specifications

## SPECIFICATIONS DVD Video Camcorder

ITEM	SPECIFICATION	ITEM	SPECIFICATION
POWER	Source: DC 7.9 / 7.2 V Consumption: Recording 4.6 W (When using Viewfinder) 4.9 W (When using LCD Monitor)	STANDARD ILLUMINATION	1,400 lx
		MINIMUM REQUIRED ILLUMINATION	1 lx (MagicPix Mode)
RECORDING FORMAT	DVD-Video Recording format (DVD-RAM, DVD-RW) DVD-Video format (DVD-RW, DVD-R)	USB	Card reader / writer function, USB 2.0 compliant (Hi-Speed) No copyright protection support / PictBridge - compliant
RECORDING / PLAYBACK TIME	XP mode : approx. 18min. with one side RAM disc SP mode : approx. 37min. with one side RAM disc LP mode : approx. 75min. with one side RAM disc		
CAMERA	Filter Diameter: 37.0 mm	VIDEO FLASH	GN 4.8
	Zoom: 10:1 Power Zoom	MICROPHONE	Stereo (with a zoom function)
	Monitor: 2.7-inch LCD	SPEAKER	1 round speaker $\phi$ 20 mm
	Lens: Auto Iris, F1.8-F2.8, Focal Length; 3.0 - 30.0 mm Macro (Full Range AF)	OPERATING TEMPERATURE	0°C - 40°C (32°F - 104°F)
	Image Sensor: 1/6-inch 3CCD Image Sensor	OPERATING HUMIDITY	10% - 80%
	Viewfinder: Color Electronic Viewfinder	WEIGHT	Approx. 585 g (without supplied battery and DVD disc)
VIDEO	Television System : EIA Standard : 625 Lines, 50 Fields PAL Colour Signal	DIMENSIONS	Approx. 63 mm (W) × 87 mm (H) × 138 mm (D) (excluding the projection parts)
	Video Output Level: 1.0 Vp-p, 75 ohm (AV Multi Jack) S-Video Output Level: Y Output; 1.0 Vp-p, 75 ohm (AV Multi Jack) C Output; 0.3 Vp-p, 75 ohm	STANDARD ACCESSORIES	1 pc. AC Adaptor 1 pc. Battery Pack Unit 1 pc. DC Cable 1 pc. AC Cord (Except VDR-D300GC/SG/GCS) 2 pcs. AC Cord (VDR-D300GC/SG/GCS) 1 pc. AV Multi Cable 1 pc. Remote Controller 1 pc. Universal Remote Controller (VDR-D300EE/GC/GN/SG/GCS, D308 GK) 1 pc. Bottom-type Battery 1 pc. CD-ROM 1 pc. USB Cable 1 pc. Shoulder Belt 1 pc. Lens Cleaner
AUDIO	Audio Output Level (Line): 316 mV, 600 ohm (AV Multi Jack) Mic Input: Mic sensitivity -50dB (0dB=1V/Pa, 1kHz) (Stereo Mini Jack)		
DISC RECORDING FUNCTIONS	Recording Media: 8cm (3") DVD-RAM Ver.2.1 8cm (3") DVD-RW Ver.1.1/2X-SPEED (2X/1X) 8cm (3") DVD-R for General Ver. 2.0	SOLDER	This model use lead free solder (PbF).
	Motion Picture recording format: MPEG2		
	Transfer Rate: XP mode: 9Mbps (VBR) SP mode: 5Mbps (VBR) LP mode: 2.5Mbps (VBR)		
	Audio recording format: Dolby Digital (Dolby AC3), 16bit (48KHz/2ch)		
CARD MEMORY FUNCTIONS	Recording Media: SD Memory Card Still picture recording file format: JPEG (Desing rule for Camera File system, based on Exif 2.2 standard), DPOF corresponding Still Image Size: Mega Pixel Recording; 2048 × 1512 (3.1 million pixels, 4:3 Mode) 1920 × 1080 (2.1 million pixels, 16:9 Mode) 1280 × 960 (1.2 million pixels, 4:3 Mode) 640 × 480 (0.3 million pixels, 4:3 Mode)		

Weight and dimensions are approximate values.  
Specifications may change without prior notice.

# 5 Location of Controls and Components

## Parts identification and handling

- 1 Lens (LEICA DICOMAR)
- 2 Built-in flash
- 3 Recording lamp
- 4 White balance/remote control sensor
- 5 Terminal cover
- 6 Audio-video output terminal [A/V]
- 7 USB terminal [↔]
- 8 Lens cover
- 9 Microphone (built-in, stereo)
- 10 Microphone terminal [MIC]
  - A compatible plug-in powered microphone can be used as an external microphone.
  - When the unit is connected with AC adaptor, sometimes noise may be heard depending on microphone type. In that case, please switch to battery for power supply and noise will stop.

**11 Viewfinder**

Due to limitations in LCD production technology, there may be some tiny bright or dark spots on the viewfinder screen. However, this is not a malfunction and does not affect the recorded picture.

- 12 Delete button [↵]
- 13 LCD monitor open part [OPEN]
- 14 Battery/DC cable holder
- 15 Power switch [OFF/ON]
- 16 Status indicator
- 17 Mode dial
- 18 Joystick
  - Move up, down, left or right to select items.
  - Press the centre to enter the selection.
- 19 Recording start/stop button
- 20 Menu button [MENU]

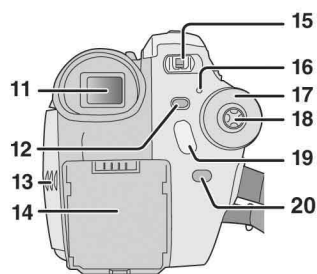
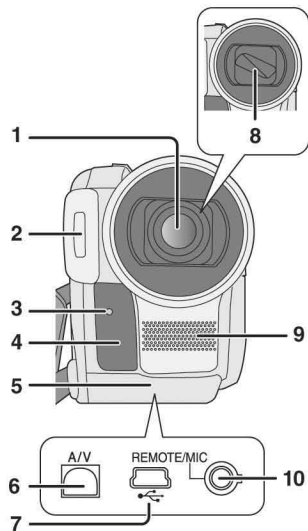

*Parts identification and handling*

**21 Accessory shoe**

- Accessories, such as a stereo microphone (optional), are attached here.

**22 Eyepiece corrector knob**

**23 Zoom lever [W/T]**

Volume lever [-VOLUME+]

**24 Photoshot button [PHOTO SHOT]**

**25 Card slot cover**

**26 Card slot**

**27 Tripod receptacle**

**28 Card access lamp**

**29 Battery release lever [BATTERY RELEASE]**

**30 Speaker**

**31 LCD monitor**

Due to limitations in LCD production technology, there may be some tiny bright or dark spots on the LCD monitor screen. However, this is not a malfunction and does not affect the recorded picture.

**32 Mode select switch [AUTO/MANUAL/FOCUS]**

**33 Power LCD button [POWER LCD]**

**34 Reset button [RESET]**

**35 Disc eject lever [DISC EJECT]**

**36 Disc/computer access lamp [ACCESS/PC]**

**37 Disc compartment**

**38 Grip belt**

**39 Shoulder strap fixture**

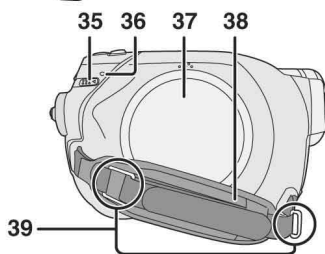
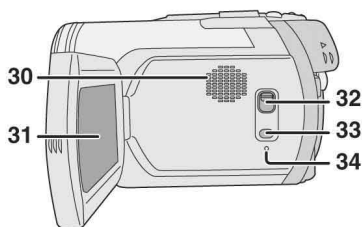
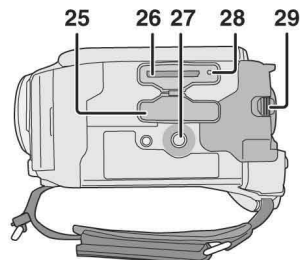
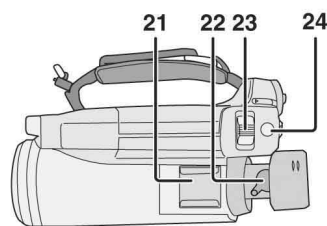

Parts identification and handling

**Using the remote control**

- 1 Photoshot button [PHOTO SHOT]\*
  - 2 On-screen display button [EXT DISPLAY]
  - 3 Date/time button [DATE/TIME]
  - 4 Playback operation buttons
  - 5 Delete button [ ]\*
  - 6 Direction buttons [▲, ▼, ◀, ▶]
  - 7 Recording start/stop buttons [START/STOP]\*
  - 8 Zoom/volume buttons [ZOOM, VOL]\*
  - 9 Menu button [MENU]\*
  - 10 Enter button [ENTER]
- \* means that these buttons function in the same manner as the corresponding buttons on the unit.

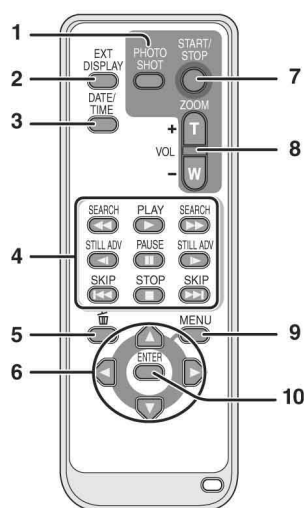

■ Install a button-type battery

Install the button-type battery supplied in the remote control before using it.

- 1 While pressing the stopper **A**, pull out the battery holder.
- 2 Set the button-type battery with its (+) mark facing upward and get the battery holder back in place.

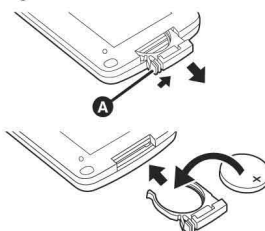

■ Concerning the button-type battery







- When the button-type battery runs down, replace it with a new battery (part number: CR2025). The battery is normally expected to last about 1 year, but it depends on operation frequency.
- Keep the button-type battery out of the reach of children.

**WARNING**

“THE LITHIUM BATTERY IS A CRITICAL COMPONENT (TYPE NUMBER CR2025 MANUFACTURED BY PANASONIC). IT MUST NEVER BE SUBJECTED TO EXCESSIVE HEAT OR DISCHARGE. IT MUST THEREFORE ONLY BE FITTED IN EQUIPMENT DESIGNED SPECIFICALLY FOR ITS USE. REPLACEMENT BATTERIES MUST BE OF THE SAME TYPE AND MANUFACTURER. THEY MUST BE FITTED IN THE SAME MANNER AND LOCATION AS THE ORIGINAL BATTERY, WITH THE CORRECT POLARITY CONNECTIONS OBSERVED. DO NOT ATTEMPT TO RE-CHARGE THE OLD BATTERY OR RE-USE IT FOR ANY OTHER PURPOSE. IT SHOULD BE DISPOSED OF IN WASTE PRODUCTS DESTINED FOR BURIAL RATHER THAN INCINERATION.”

## Discs and cards

### Discs that can be used on this unit

Disc type	DVD-RAM 8 cm Single sided/ double sided	DVD-RW 8 cm Single sided/double sided		DVD-R 8 cm Single sided/ double sided
	 (DVD-RAM Ver. 2.1)	 [DVD-RW Ver. 1.1/ 2X-SPEED (2X/1X)]		 (DVD-R for General Ver. 2.0)
Recording format	DVD Video Recording format (VR format)	DVD Video Recording format (VR format)	DVD-Video format (Video format)	DVD-Video format (Video format)
Characteristic	Rewritable disc	Rewritable disc	One time recording disc*1	One time recording disc
Display on the screen				
Indication in these instructions	<b>RAM</b>	<b>-RW(VR)</b>	<b>-RW(V)</b>	<b>-R</b>
Functions				
• Deleting recorded scenes	●	●	—	—
• Editing on this unit	●	●	—	—
• Playback on other products*2	●*3	●*4	●*5	●*5
• Recording after finalizing	—	●	●*6	—

●: available —: not available

\*1 By formatting the disc, it can be used repeatedly.

\*2 DVD players and DVD recorders that support 8 cm discs.

\*3 Playback is possible on compatible products.

\*4 Playback is possible on compatible products. (May have to be finalized on this unit.)

\*5 Must be finalized on this unit.

\*6 Un-finalize the disc.

## Discs and cards

- **Still pictures cannot be recorded on a disc with this unit.**
- When using double sided disc, you cannot record or play continuously from one side of the disc to the other. You will need to eject the disc and turn it over.
- Discs inserted in a holder, cartridge, or caddy case cannot be used. Always remove bare discs from these containers prior to use.
- It is recommended that you use Panasonic discs. Usually discs compatible with the DVD standard can be used for recording and playback with no problems. However, some commercially available discs do not meet the DVD standard for quality and performance.
- Discs recorded on this unit may not be playable on other products.
- Recording on DVD-R in DVD Video Recording format is not supported.
- When using DVD-RW or DVD-R, do not perform the following, as doing so may make the disc unusable.
  - Record on a disc with other products after recording on it with this unit.
  - Record on a disc with this unit after recording on it with other products.
  - Insert an un-finalized disc in any other products.

### ■ About format types

#### What is the DVD Video Recording format (VR format)?

This is a format for recording on DVD discs which allows you to record and erase repeatedly and create playlists. You can record on DVD-RAM and DVD-RW in DVD Video Recording format with this unit.

#### What is the DVD-Video format (Video format)?

By finalizing the disc, it can be played back on most DVD players.

You can record on DVD-RW and DVD-R in DVD-Video format with this unit.

### ■ Examples of discs that cannot be used on this unit

- |  |             |               |
|--|-------------|---------------|
| ● DVD-RAM (2.6 GB) Ver. 1.0                    | ● DVD-ROM   | ● MO          |
| ● DVD-R (3.9 GB) Ver. 1.0                      | ● DVD-Video | ● MD          |
| ● DVD-R (4.7 GB) for Authoring Ver. 2.0        | ● CD-R      | ● iD          |
| ● +RW  | ● CD-RW     | ● Floppy disk |
| ● +R   | ● CD        | ● CD-ROM      |
| ● DVD-R DL                                     | ● LD        |               |
| ● Discs other than those with diameter of 8 cm |             |               |
| ● Dual/double layer discs                      |             |               |



*Discs and cards***When using brand-new DVD-RW**

When using DVD-RW, select whether to record in DVD Video Recording format (VR format) or DVD-Video format (Video format) and then format the disc.

- 1 When a brand-new DVD-RW is inserted in this unit, the screen on the right appears. Select [YES], then press the joystick.**



- 2 Select format type, then press the joystick.**

**VIDEO:** DVD-Video format  
**VR:** DVD Video Recording format



- 3 When the confirm screen appears, select [YES], then press the joystick.**

- To change the format type, format the disc again.  
 If the disc is formatted, then all the data recorded on the disc will be erased.

## Discs and cards

## Cards that you can use with this unit

Card type	SD Memory Card
Capacity	8 MB, 16 MB, 32 MB, 64 MB, 128 MB, 256 MB, 512 MB, 1 GB, 2 GB (Maximum)
Indication in these instructions	

- **Motion pictures cannot be recorded on an SD card with this unit.**
- For the purposes of these operating instructions, SD Memory Card and miniSD™ Card are referred to as the "SD card".
- This unit supports SD cards formatted in FAT12 system and FAT16 system based on SD Memory Card Specifications.
- Use this unit to format SD cards. If an SD card is formatted on other products (such as a computer), the time spent for recording may become longer and you may not be able to use the SD card.
- We recommend that you use a Panasonic brand SD card.
- When the write-protect switch on SD Memory Card is locked, no recording, deletion or editing will be possible on the card.

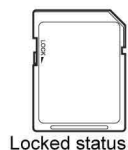
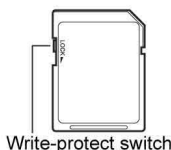

- Keep the memory card out of reach of children to prevent swallowing.
- A MultiMediaCard cannot be used on this unit.

#### ■ About the miniSD™ Card

- Be sure to insert miniSD™ Cards in the dedicated card adaptor before use. Inserting a card in this unit without the adaptor may damage the unit or the card.
- Do not insert an empty card adaptor in this unit. Do not leave the adaptor in this unit while inserting or removing miniSD™ Cards. This may cause the unit to malfunction.

## Cautions for use

### About this unit

- The unit, disc and card become warm after long operation, but this is not a malfunction.

#### Keep the unit away from magnetized products/mobile phones, microwave ovens, TVs and video game products.

- If you use the unit on or near a TV, the images or sound may be disturbed due to electromagnetic wave radiation.
- Do not use near cell phone because doing so may cause noise to adversely affect the picture and sound.
- Recordings may be damaged, or images may be distorted, by the strong magnetic fields created by speakers or large motors.
- Electromagnetic wave radiation generated by digital circuits including microprocessors may adversely affect the unit, causing the disturbance of images and sounds.
- If the unit is affected by such products and does not function properly, turn off the unit and detach the battery or AC adaptor. Then connect the battery or AC adaptor again.

#### Do not use the unit near radio transmitters or high-voltage cables.

- If you record pictures near radio transmitters or high-voltage cables, recorded images or sounds may be adversely affected.

#### Make sure to use the supplied cords and cables. If you use optional accessories, use the cords and the cables supplied with them.

#### Do not extend the cords and the cables.

#### Do not spray insecticides or volatile chemicals onto the unit.

- If the unit is sprayed with such chemicals, its body may be marred and the surface finish may peel off.
- Do not leave rubber or plastic products in contact with the unit for a long time.

#### When you use the unit in a sandy or dusty place such as a beach, do not let sand or fine dust get into the body and terminals of the unit.

#### Also, keep the unit away from sea water.

- Sand or dust may damage the unit. (Care should be taken when inserting and removing a disc or a card.)
- If sea water splashes onto the unit, wipe off the water with a well wrung cloth. Then wipe the unit again with a dry cloth.

#### When carrying the unit, do not drop or bump it.

- A strong impact can break the unit's casing, causing it to malfunction.

#### Do not use benzene, paint thinner or alcohol for cleaning the unit.

- Before cleaning, detach the battery or pull out the AC cable from the AC outlet.
- The camera body may be discoloured and the surface finish may peel off.
- Wipe the unit with a soft dry cloth to remove dust and fingerprints. To remove stubborn stains, thoroughly wring a cloth that has been soaked in a neutral detergent diluted with water and wipe the unit with it. Afterwards, wipe it with a dry cloth.
- When you use a chemical dust cloth, follow the instructions that came with the cloth.

## Cautions for use

### Do not touch the laser pickup lens.

- If you touch the laser pickup lens directly it may cause malfunctions.

### Do not use a commercial available 8 cm CD lens cleaner.

- Using 8 cm CD lens cleaner could cause this unit to malfunction.

### Do not use the unit for surveillance purposes or other business uses.

- If you use the unit for a long time, heat will build up inside it and this may cause a malfunction.
- This unit is not intended for business use.

### When you are not going to use the unit for an extended time

- When storing the unit in a cupboard or cabinet, it is recommended that you place a desiccant (silica gel) in with it.

## About the battery

The battery used in this unit is a rechargeable lithium-ion battery. It is susceptible to humidity and temperature and the effect increases the more the temperature rises or falls. In cold areas, the full charge indication may not appear or the low battery indication may appear about 5 minutes after starting use. At high temperatures, the protection function may be triggered, making it impossible to use the unit.

### Be sure to detach the battery after use.

- If the battery is left attached, a minute amount of current continues to flow even if the unit's power is off. Keeping the unit in this state may result in over discharge of the battery. This may result in you not being able to use the battery even after it is charged.
- The battery should be stored in the vinyl bag so metal does not come into contact with the terminals.
- The battery should be stored in a cool place free from humidity, with as constant temperature as possible. (Recommended temperature: 15 °C to 25 °C, Recommended humidity: 40% to 60%)
- Extremely high temperatures or low temperatures will shorten the life of the battery.

- If the battery is kept in high-temperature, high-humidity, or oily-smoky places, the terminals may rust and cause malfunctions.
- To store the battery for a long period of time, we recommend you charge it once every year and store it again after you have completely used up the charged capacity.
- Dust and other matter attached to the battery terminals should be removed.

### Prepare spare batteries when going out for recording.

- Prepare batteries appropriate to 3 to 4 times the period during you want to record pictures in. In cold places such as a ski resort, the period during which you can record pictures is shortened.
- When you travel, do not forget to bring an AC adaptor so that you can recharge the batteries at your destination.

### If you drop the battery accidentally, check to see if the terminals are damaged.

- Attaching a battery with damaged terminals can damage the unit or AC adaptor.

### Do not throw old battery into fire.

- Heating a battery or throwing it into a fire may result in an explosion.
- If the operating time is very short even after the battery has been recharged, the battery has worn out. Please purchase a new battery.

*Cautions for use***About the AC adaptor**

- If the battery is warm, charging requires more time than normal.
- If the temperature of the battery is extremely high or extremely low, the CHARGE lamp may continue flashing, and the battery may not be charged. Wait until the appropriate temperature is restored before charging the battery again. If the battery still fails to charge, something may be wrong with the battery or AC adaptor. Contact your dealer.
- If you use the AC adaptor near a radio, radio reception may be disturbed. Keep the AC adaptor 1 m or more away from the radio.
- When using the AC adaptor, it may generate whirring sounds. However, this is normal.
- After use, be sure to disconnect the AC adaptor. (If it is left connected, a minute amount of current is consumed.)
- Always keep the electrodes of the AC adaptor and battery clean.

**Put this unit near the outlet to make it easy for the interrupting device (plug) to reach it.**

**About the disc**

- **If there is dust, a scratch, or dirt on disc or if it is warped, the following phenomena may occur:**
  - Block noise in playback image
  - Momentary stop of playback image
  - Sound interrupted during playback, or abnormal sound
  - Thumbnail display with shades of blue and white
  - Disc cannot correctly be recognized
  - Delay between video and audio
- When recording images, this unit may avoid the portions of disc where recording is not possible, due to dust, scratches, etc. (It will pause at such a portion and automatically restart recording.)

**When the access lamp is illuminated (during access to the disc), do not open the disc cover, turn off the power, or cause any vibrations or impacts.**

**DVD-R**



- For optimum recording on DVD-R disc, this unit writes control data to the disc in order to automatically make adjustments when it is inserted and ejected accompanying recording. If the disc has no area for control data to be written, recording may not be possible. To prevent this, do not insert a DVD-R which has been recorded on more than 50 times.
- Do not insert a DVD-R recorded on this unit that has not been finalized into a recordable device, such as a DVD recorder. The recorded data may be damaged.

## Cautions for use

### About the SD card

- The memory capacity indicated on the label of an SD card is the total of the capacity for copyright protection and management and the capacity which can be used on the unit, a computer etc.
- During prolonged use, the unit's surfaces and the SD card will heat up slightly. This is normal.

**When inserting or removing the SD card, always set the OFF/ON switch to OFF.**

**While this unit accesses the SD card (while  or  is being displayed/the access lamp is lit), do not remove the SD card, operate the mode dial, turn off the power or shake or impact the unit.**

### LCD monitor/viewfinder

- When the LCD monitor gets dirty, wipe it with a dry soft cloth.
- In a place with drastic temperature changes, condensation may form on the LCD monitor. Wipe it with soft dry cloth.
- When the unit has become very cold, for example due to storage in a cold area, its LCD monitor will be slightly darker than usual immediately after the power is turned on. The normal brightness will be restored when the unit's internal temperature rises.

Extremely high precision technology is employed to produce the LCD Monitor screen featuring a total of approximately 123,000 pixels. The result is more than 99.99% effective pixels with a mere 0.01% of the pixels inactive or always lit. However, this is not a malfunction and does not affect the recorded picture.

Extremely high precision technology is employed to produce the viewfinder screen featuring a total of approximately 123,000 pixels. The result is more than 99.99% effective pixels with a mere 0.01% of the pixels inactive or always lit. However, this is not a malfunction and does not affect the recorded picture.

### About condensation

When condensation forms on the unit, the lens will cloud up and the unit may not work properly. Make every effort to ensure that condensation does not form. If it does form, take the actions described below.

#### Causes of condensation

**Condensation takes place when the ambient temperature or humidity is changed as follows.**

- When this unit is brought inside from the cold (e.g. a ski slope) to a warm room.
- When this unit is moved from an air-conditioned car to outside.
- When a cold room has been warmed up quickly.
- When cool wind from an air conditioner is directly blown onto this unit.
- After summer afternoon showers of rain.
- When this unit is in a very humid place where the air is thick with steam. (e.g. a heated swimming pool)

**When this unit is taken to a location with a significant temperature difference such as from a cold place to a hot place.**

If, for example, you have used this unit for recording on a ski slope and are taking it into a heated room, place the unit inside a plastic bag, remove as much of the air from inside the bag as possible, then seal the bag. Leave the unit for about an hour in the room so the temperature of the unit is close to the ambient temperature of the room, then use it.

**What to do with the lens is fogged up.**

Remove the battery or AC adaptor and leave the unit for about 1 hour. When the unit becomes close to the ambient temperature, the fog disappears naturally.

## 6 Service Mode

### 6.1. Error Display

"PUSH THE RESET SWITCH" is displayed automatically on the EVF or the LCD Monitor when an undesirable condition has occurred.

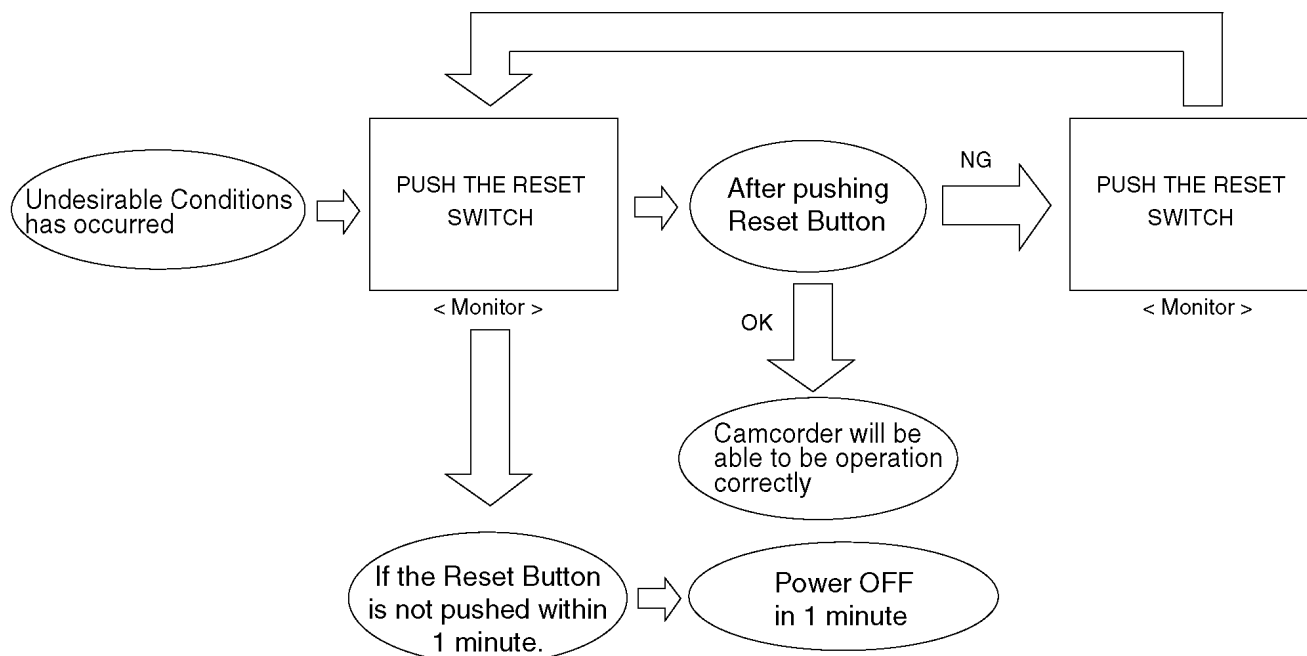

**Note:**

When "PUSH THE RESET SWITCH" is displayed repeatedly, required.  
Check the Error Code which is listed in the Service Menu.

## 6.2. Service Menu

When abnormal detection contents are confirmed a When I do the following operation automatic diagnosis code is displayed.

### 1. Preparation

(1) Remove the card and disc from this unit.

### 2. To enter the Service Menu. (see Fig. S1)

(1) Turn on power and set the Mode Dial to [DISC PLAYBACK MODE].

(2) Pushed [DELETE] button, [JOYSTICK CONTROL LEFT] button and [RECORDING START/STOP] button simultaneously for 3 seconds.

### 3. To select the Item.

(1) Press the [JOYSTICK CONTROL UP/DOWN] to select item [2] or [5].

(2) Press the [JOYSTICK CONTROL RIGHT] to display [YES/NO] screen.

(3) Press the [JOYSTICK CONTROL UP/DOWN] to select [YES].

(4) Press the [JOYSTICK CONTROL CENTER].

### 4. To exit the Service Menu.

(1) Unplug the AC Cord.

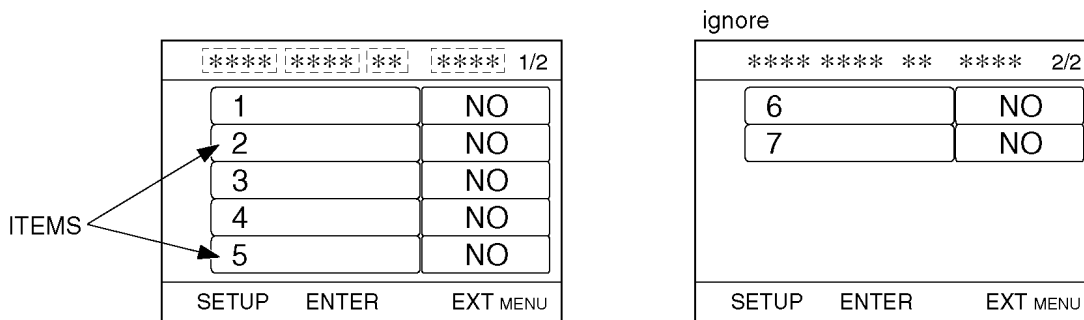

Fig. S1

### NOTE:

Do not operate items except for [2] and [5] in the Service Menu.

Self diagnosis code contents are as follows.

<Item 2>

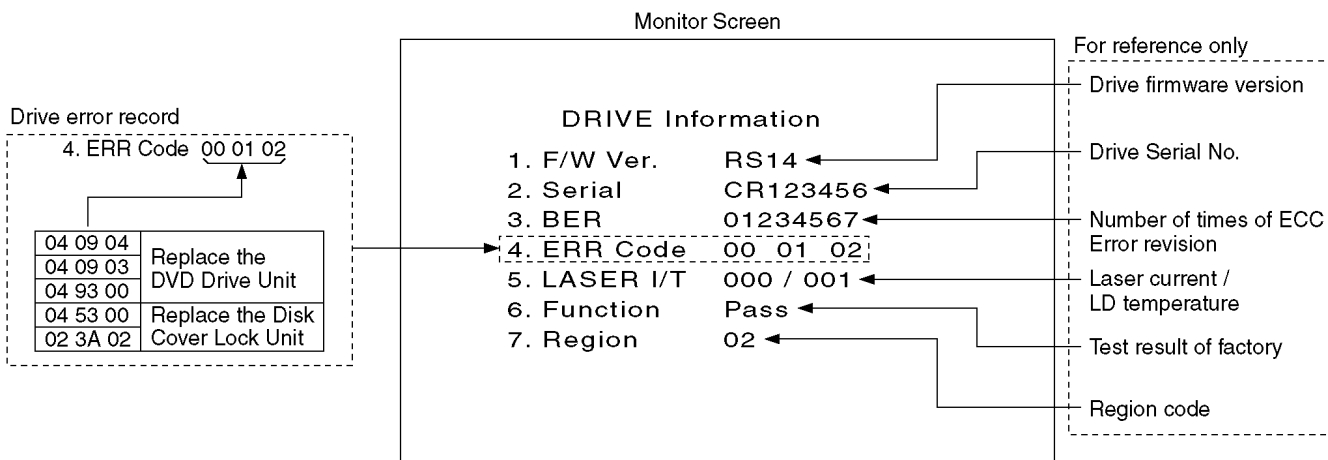



<Item 5>

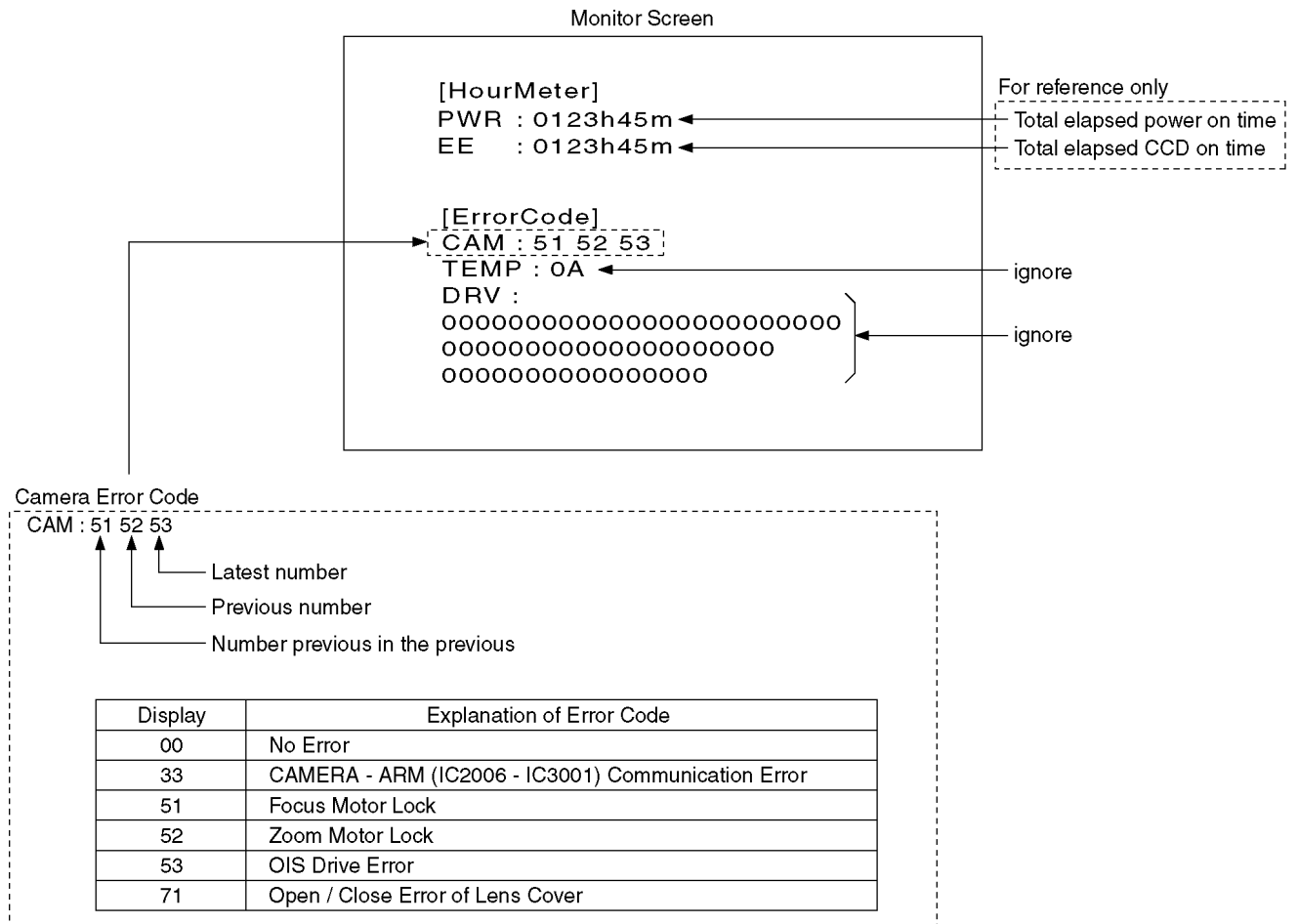

Please do the error code backup record the clear after repair completion.

**CLEAR METHOD**

If the Card and Tape inserted, take out it before Service Mode operation.

Turn on power and set the Mode Dial to [DISC RECORDING MODE].

Pushed [DELEATE] button, [JOYSTICK CONTROL RIGHT] and [RECORDING START/STOP] button simultaneously for 3 seconds.

## 6.3. Firmware Version Check

After servicing and making repairs, update the firmware to the latest version.

### A. Preparation

1. Remove the card and disc from this unit.
2. When USB cable is connected, disconnect the USB cable.

### B. Checking Procedure

1. Turn on power and set the Mode Dial to [DISC PLAYBACK MODE].
2. Push the [DELETE] button, [JOYSTICK CONTROL LEFT] and [RECORDING START/STOP] button simultaneously for few seconds.
3. Confirm ARM Firmware and DVD Drive Firmware.

ARM Firmware version (043B:Example)	Drive firmware version (RS35:Example)
[043B] ***** **	[RS35] 1/2
1	NO
2	NO
3	NO
4	NO
5	NO
SETUP	ENTER      EXT MENU

4. Push the [MENU] button to release the service menu.

#### Note:

When it is the newest same version, it is not necessary already to update it.

## 7 Service Fixture & Tools

### 7.1. Service Tools and Equipment

Parts Name	Parts No.	Part No.(sub)	Q'ty	Remarks
PC	---	---	1	
AC Adaptor	---	---	1	
DC Cable	---	---	1	
AV Multi Cable	---	---	1	
USB Cable	---	---	1	
PC-Adjustment Program	---	---	1	
Step up Ring	VFK1164TAR37	---	1	37mm
Light Box	VFK1164LBX1	---	1	
Infinity Lens	VFK1164TCM02	---	1	With Focus Chart
Extension Cable (20pin)	VFK1461	LSUA0020	1	PS6003 (Sub) - FP6501 (Front)
Extension Cable (10pin)	VFK1440	---	1	FP6502 (Front) - Barrier Motor Unit
Extension Cable (60pin)	LSUA0059	---	1	B1 (Main) - DVD Drive Unit
Extension Cable (26pin)	VFK1492	---	1	FP4 (Main) - FP902 (Monitor)
Extension Cable (24pin)	VFK1284	---	1	FP1 (Main) - FP6301 (Side R)
Extension Cable (16pin)	VFK1286	---	1	FP2 (Main) - Rear / Shoe Angle Unit
Extension Cable (26pin)	VFK1492	---	1	FP3 (Main) - Side L / Operation Unit
Extension Cable (22pin)	VFK1282	---	1	FP5 (Main) - FP951 (EVF)
Extension Cable (150pin)	VFK1992	---	1	B4 (Main) - PS6001 (Sub)
Extension Cable (33pin)	VFK1950	VFK1575C3320	1	FP6002(Sub) - Lens Unit
Extension Cable (39pin)	VFK1459	---	1	FP6001(Sub) - Prism Unit

# 8 Disassembly and Assembly Instructions

## 8.1. Disassembly Frow Chart

This flow chart indicates the disassembly steps the cabinet parts, P.C.B. and Mecha. Unit in order to access to be serviced. When reinstalling, perform the steps in the reverse order.

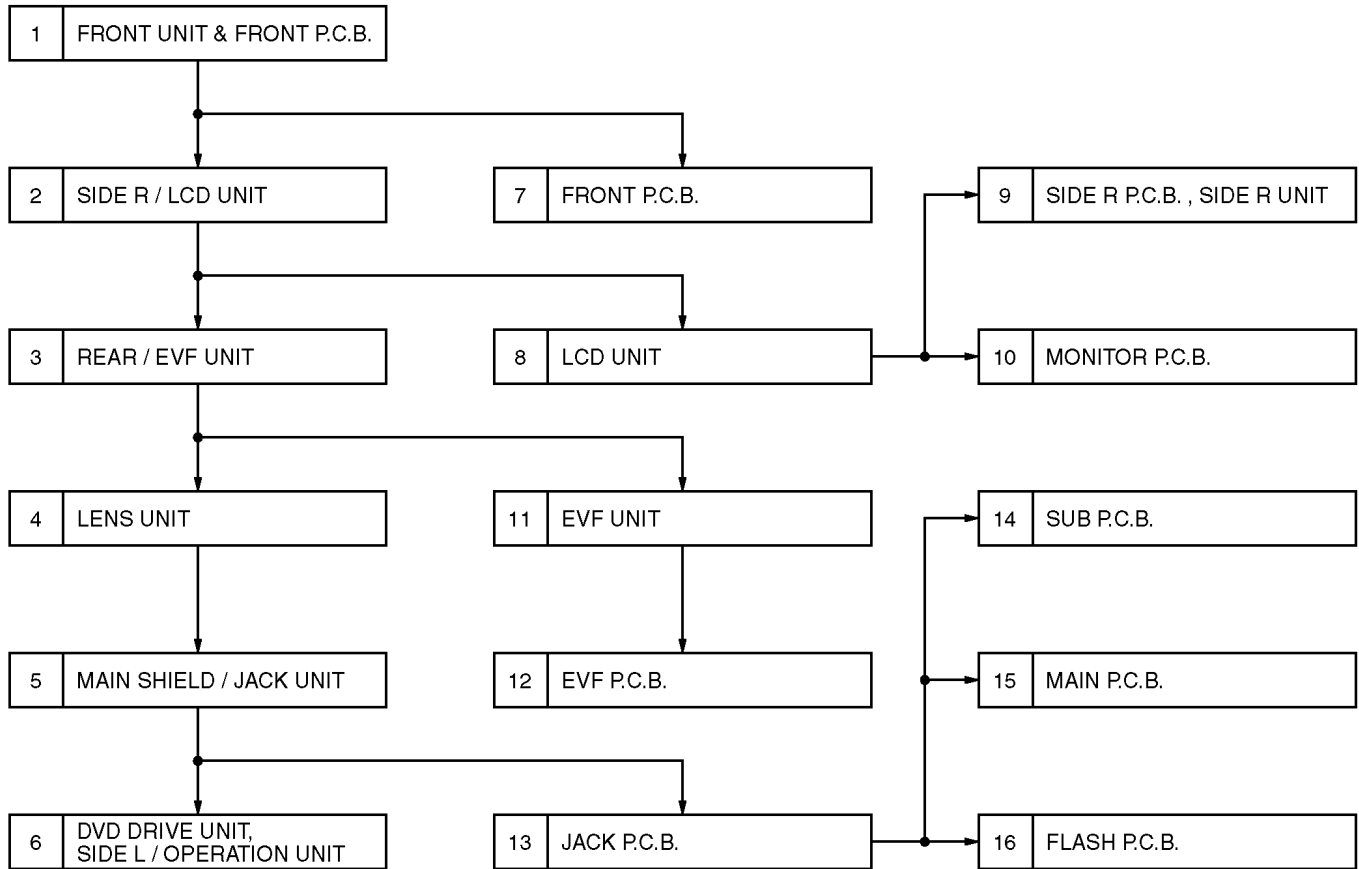

## 8.2. P.C.B. Layout

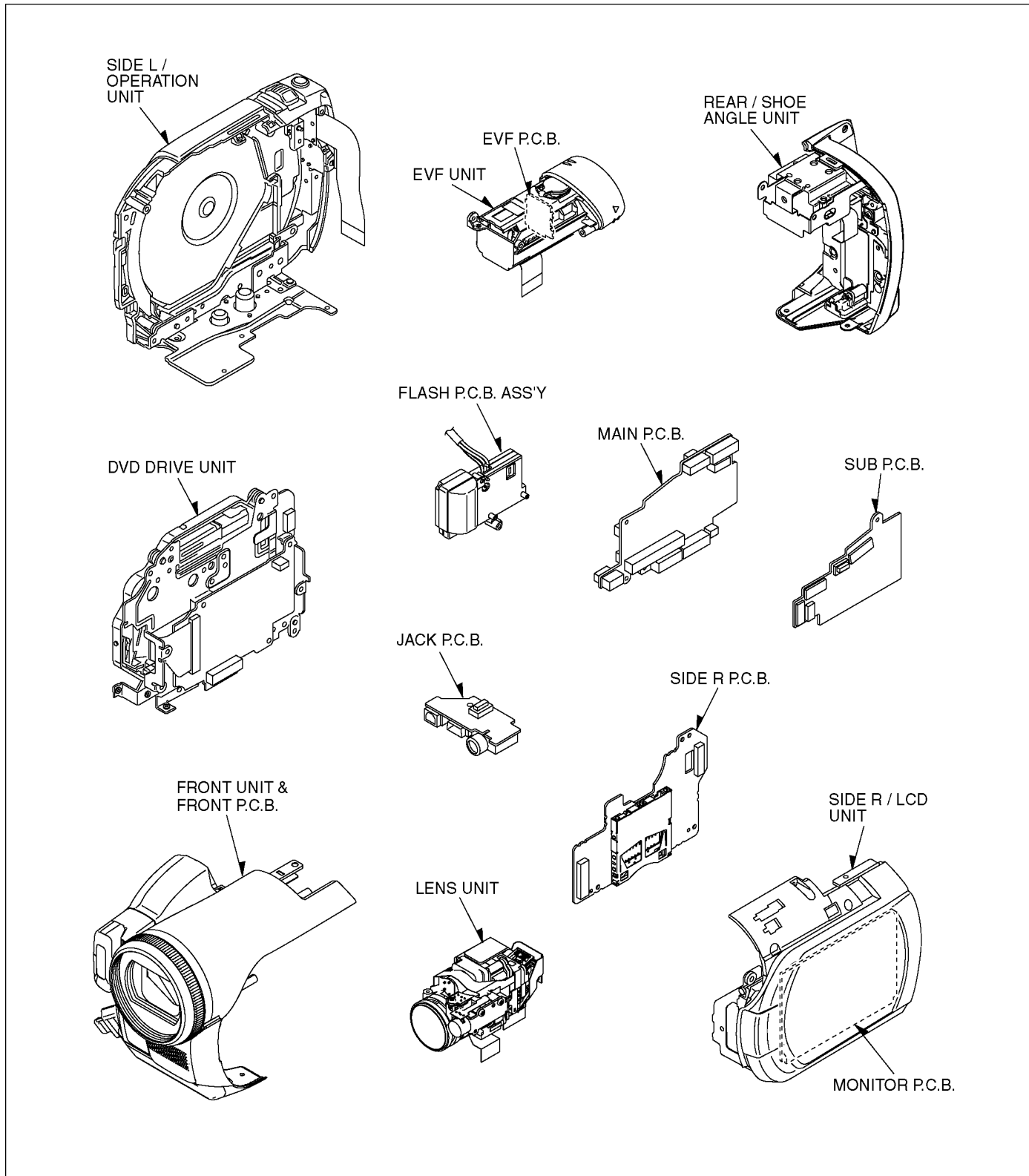

Fig. F1

### 8.3. Disassembly Procedures

Flow-Chart for Disassembly Procedure

No.	Item / Part	Fig.	Removal (Screw,Connector,FPC. & Other)
1	FRONT UNIT & FRON P.C.B.	Fig.D2	Detach the Grip Belt
		Fig.D3	3-Screws (A) Shoe Plate 1-Screws (B) 3-Tabs Shoe Base
		Fig.D4	Open the LCD Unit 1-Screw (D)
		Fig.D5	1-Screw (D), 1-Screw (E)
		Fig.D6	Open the Jack Cover 3-Screws (F)
		Fig.D7	2-Tabs FP6501 Remove the Front Unit & Front P.C.B. in the direction of the arrow.
2	SIDE R/LCD UNIT	Fig.D8	3-Screws (G)
		Fig.D9	3-Screw (H) Support Angle 2-Screws (I), 1-Screw (J) FP1, FP4 Side R/LCD Unit
3	REAR/EVF UNIT	Fig.D10	Slide out the EVF. 6-Screws (K) FP2, FP5 Rear/EVF Unit
4	LENS UNIT	Fig.D11	FP6001, FP6002 1-Screw (L) Lens Unit
5	MAIN SHIELD/JACK UNIT	Fig.D12	FP3 4-Screws (M), 1-Screw (N) Drive FPC (B2401) Main Shield Unit 1-Screw (O) Flash Trigger Unit
6	DVD DRIVE UNIT, SIDE L /OPERATION UNIT	Fig.D13	Disk Cover Lock FPC Slide the Lock Lever of Disk Cover Lock Unit to open the Disk Cover
		Fig.D14	1-Screw (P), 1-Screw (Q) Disk Cover Lock Unit
		Fig.D15	1-Screw (R) DVD Drive Unit, Side L/ Operation Unit
7	FRONT P.C.B.	Fig.D16	FP6502 3-Screws (S) Front P.C.B.
8	LCD UNIT	Fig.D17	2-Screws (T) Side R Piece 1-Screw (U) LCD Open SW
		Fig.D18	Open the LCD, and Turn the LCD. 2-Screws (V) LCD Unit, 2-Earth Plates
9	SIDE R UNIT, SIDE R P.C.B.	Fig.D19	5-Screws (W) Speaker Plate Side R Unit, Side R P.C.B.
10	MONITOR P.C.B.	Fig.D20	2-Screws (X) 6-Tabs LCD Case A unit
		Fig.D21	FP902 Shaft Case Unit, LCD Earth Spring
		Fig.D22	FP903 3-Tabs Monitor P.C.B.
11	EVF UNIT	Fig.D23	1-Screw (Y) Roll up the EVF FPC, and pull out the EVF Unit in the direction of the arrow.

No.	Item / Part	Fig.	Removal (Screw,Connector,FPC. & Other)
12	EVF P.C.B.	Fig.D24	Rib (1) of EVF Case Unit removed from the slot of EVF Slide Base Unit, Rib (2) of EVF Case Unit is removed by twisting EVF Case Unit in the direction of the arrow. EVF Case Unit, EVF Slide Base Unit
		Fig.D25	2-Tabs EVF LCD Panel Unit
		Fig.D26	FP952 4-Tabs EVF P.C.B.
13	JACK P.C.B.	Fig.D27	1-Screw (Z) B7001, B2 Jack P.C.B.
14	SUB P.C.B.	Fig.D28	P6601, P6602 Release the Cable of Flash Trigger from Heat Sink Unit. 1-Screw (a) 2-Tabs Shield Plate 2-Screws (b) Main/Sub/Flash Board Unit
		Fig.D29	B4, PS6001 Sub P.C.B.
15	MAIN P.C.B.	Fig.D30	2-Screws (c) B5, B6001 Main P.C.B., Flash Board Unit
16	FLASH P.C.B.	Fig.D31	2-Tabs Capacitor Holder A, Capacitor Holder B Flash P.C.B.

**CAUTION**



Laser light striking the eye may cause your eyesight to be lost : For safety, be sure to remove any power supply (AC adaptor/ charger, battery, etc.) from the DVD video camera/recorder before starting work.

<CSA requirement>

**CAUTION: VISIBLE LASER RADIATION DO NOT STARE INTO THE BEAM OR VIEW DIRECTLY WITH OPTICAL INSTRUMENTS CLASS 2M**

If the Card inserted, take out it before disassembling.

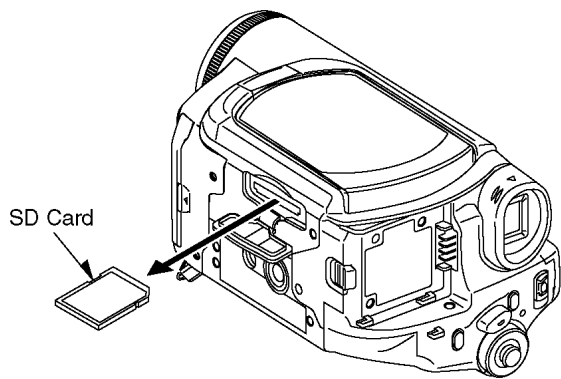

Fig. D1

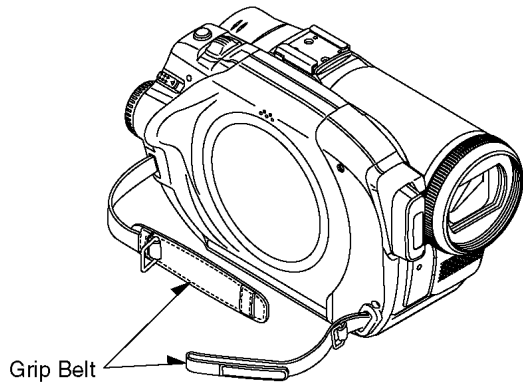

Fig. D2

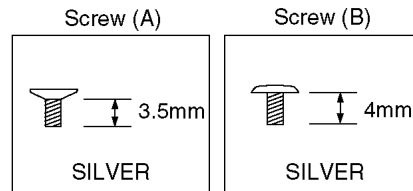
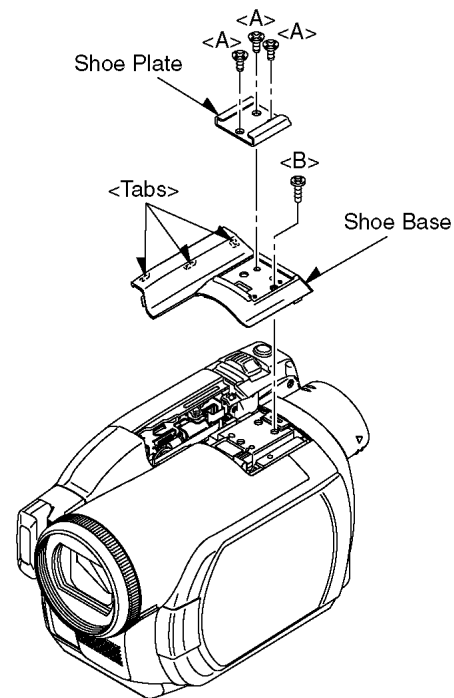

Fig. D3

Open the LCD Unit

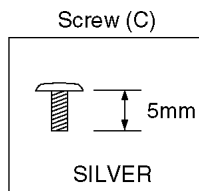
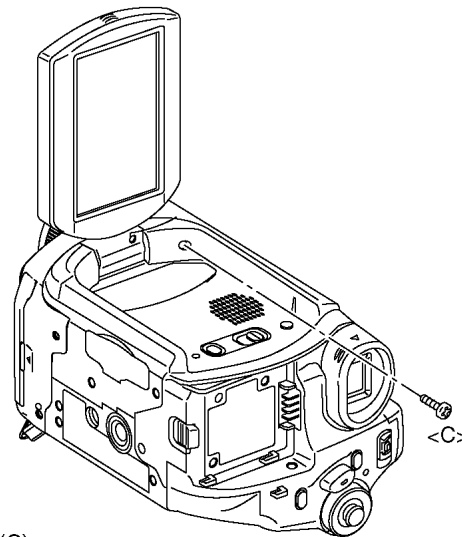

Fig. D4

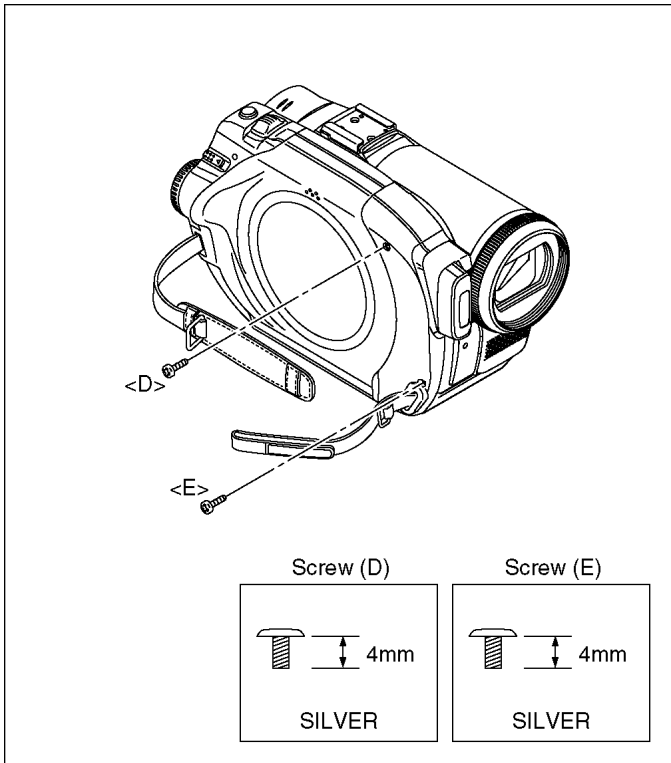

Fig. D5

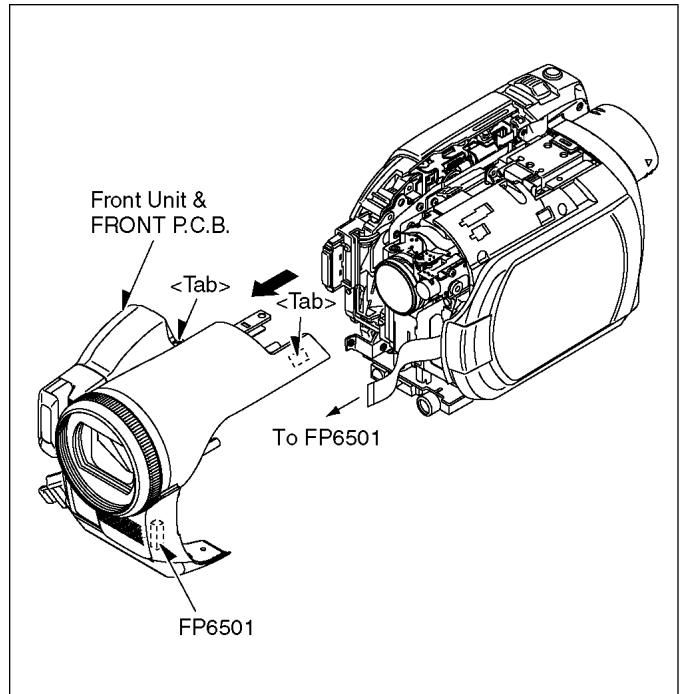

Fig. D7

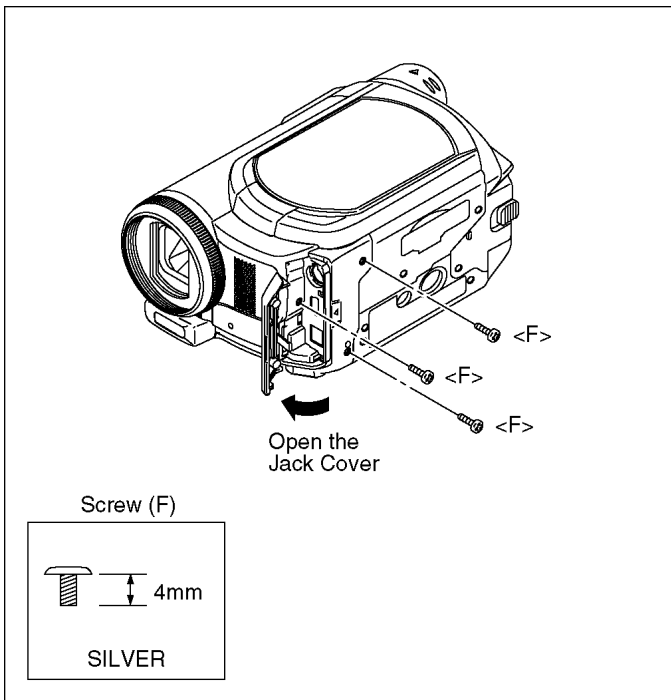

Fig. D6

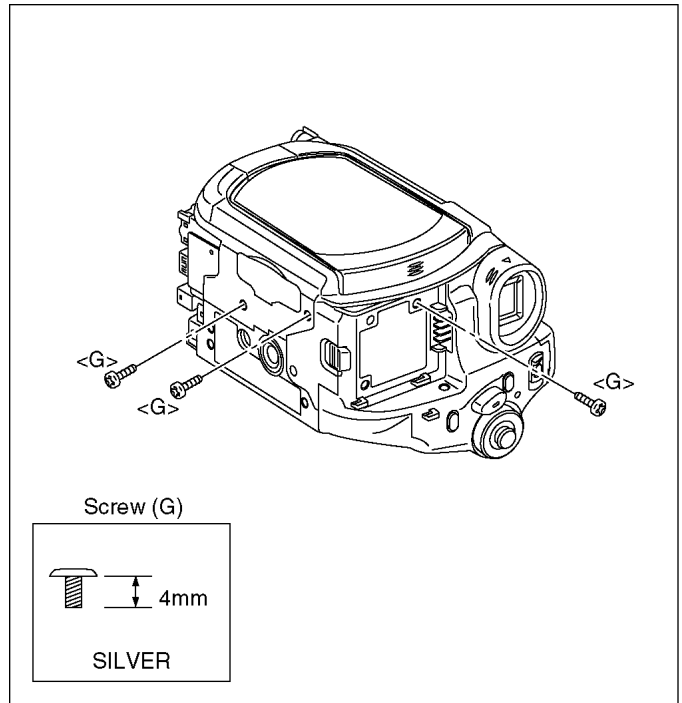

Fig. D8



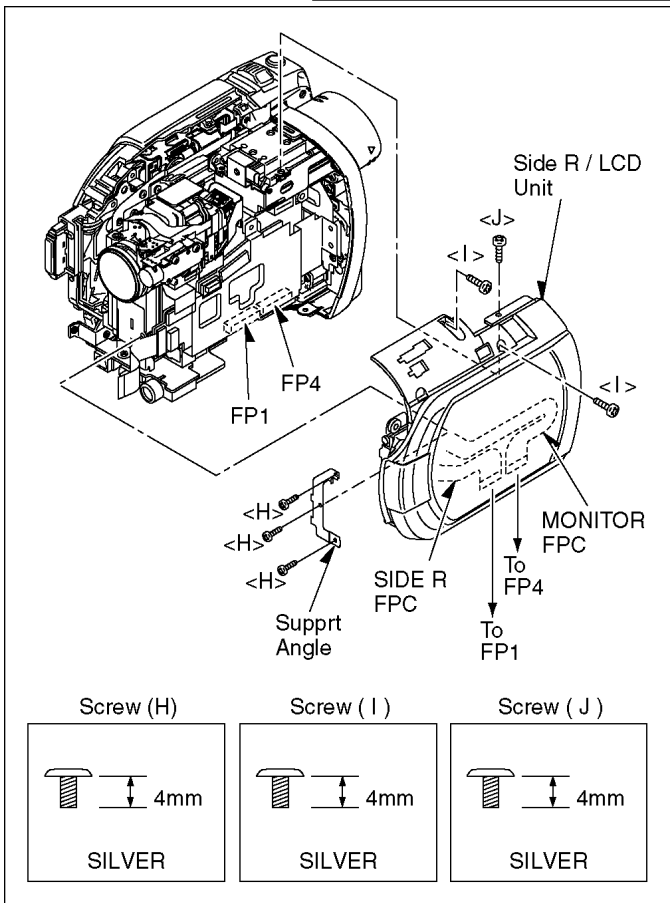

Fig. D9

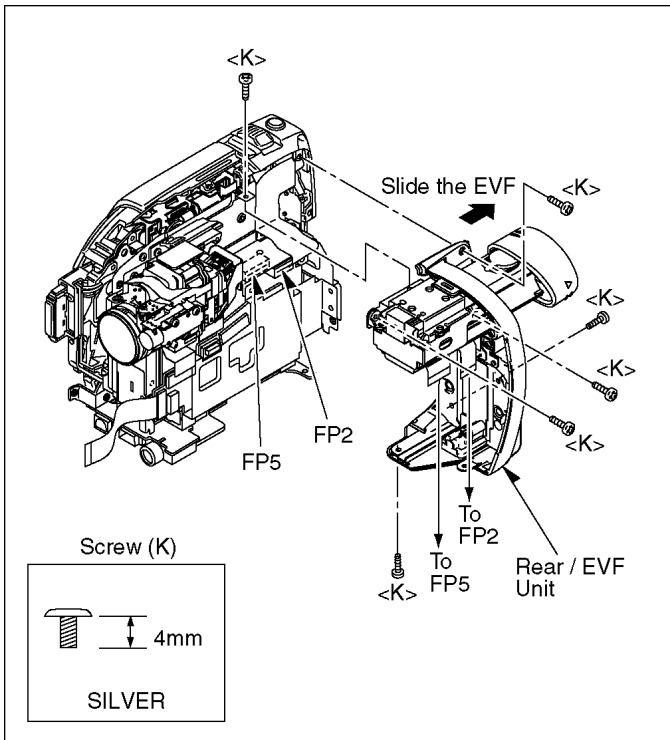

Fig. D10

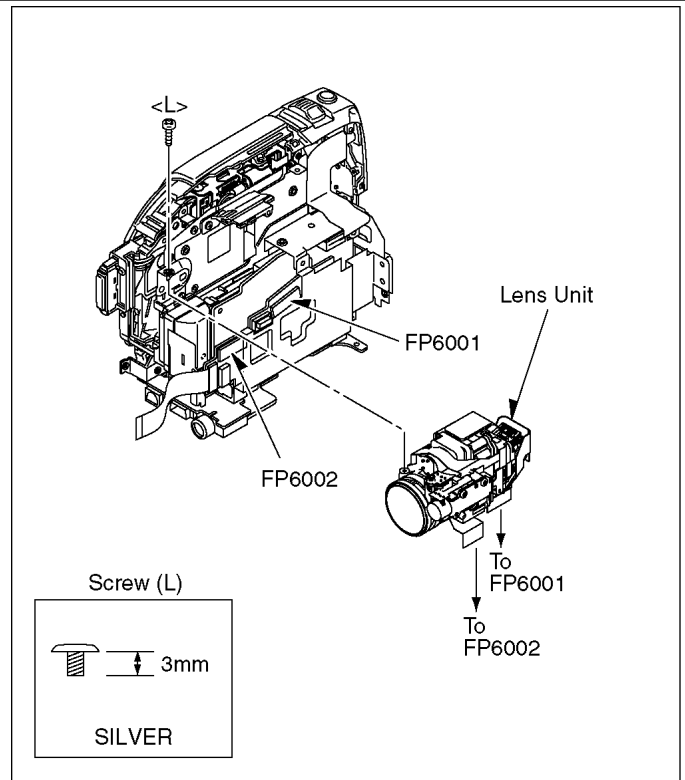

Fig. D11

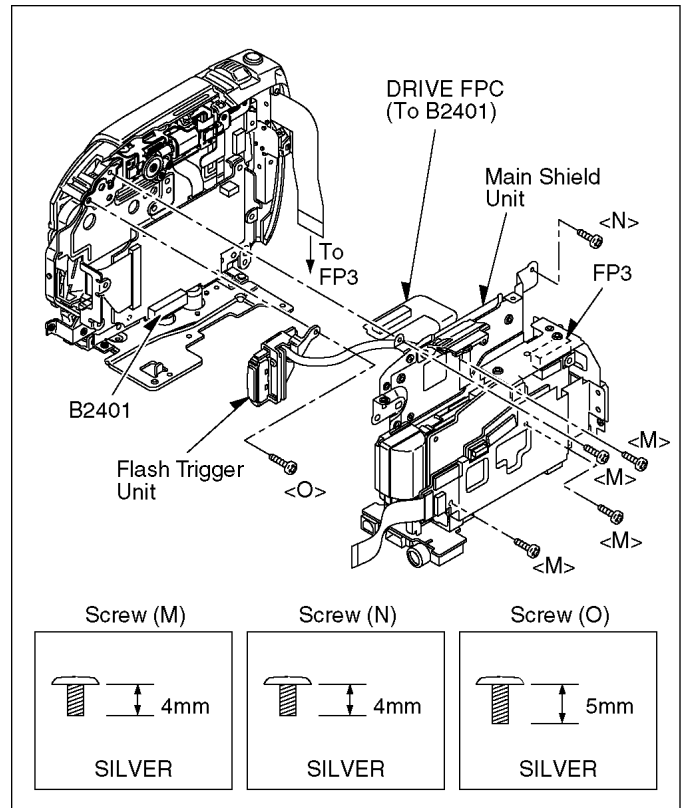

Fig. D12

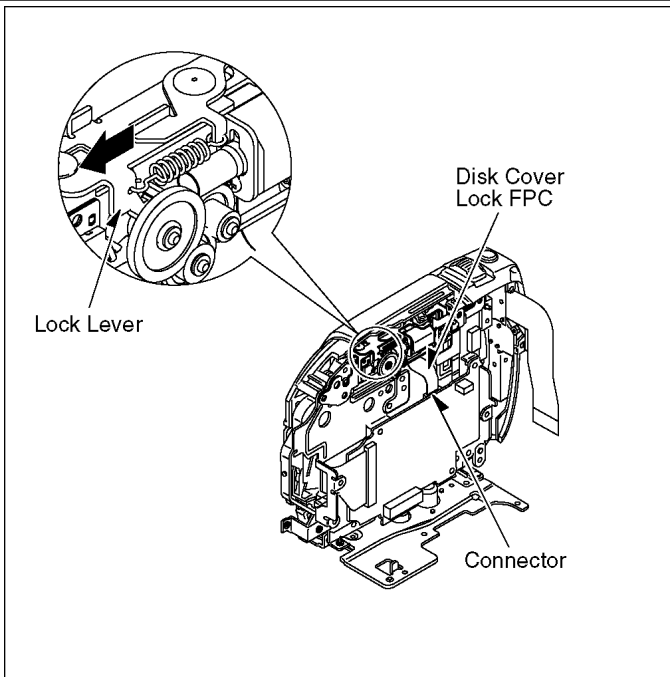

Fig. D13

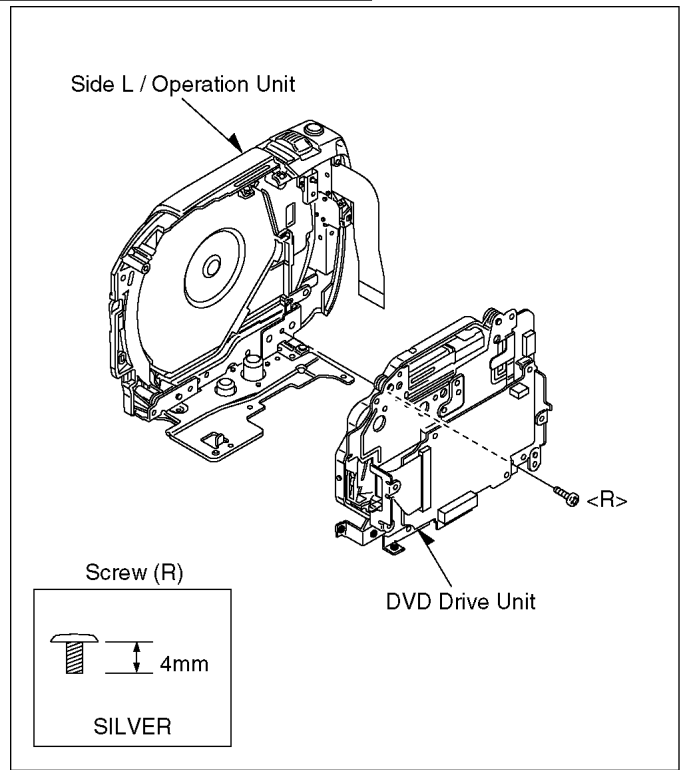

Fig. D15

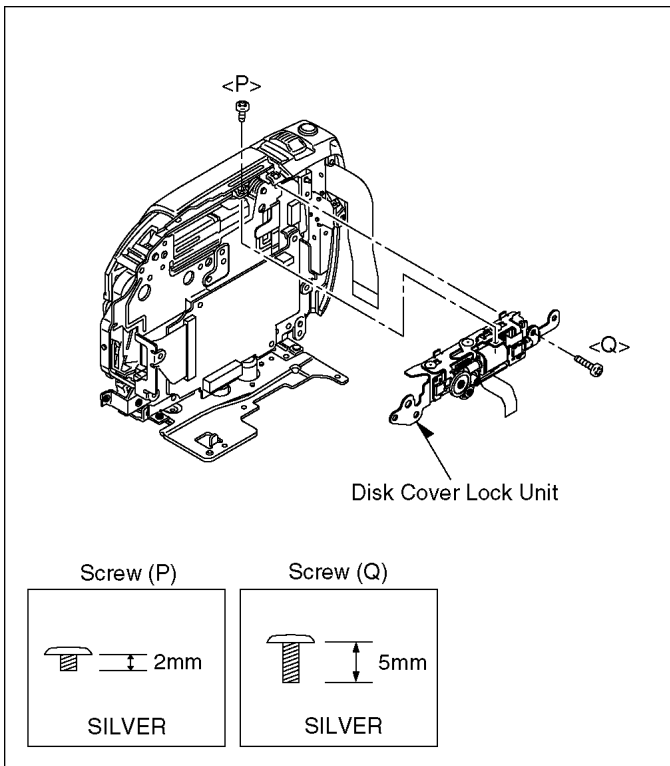

Fig. D14

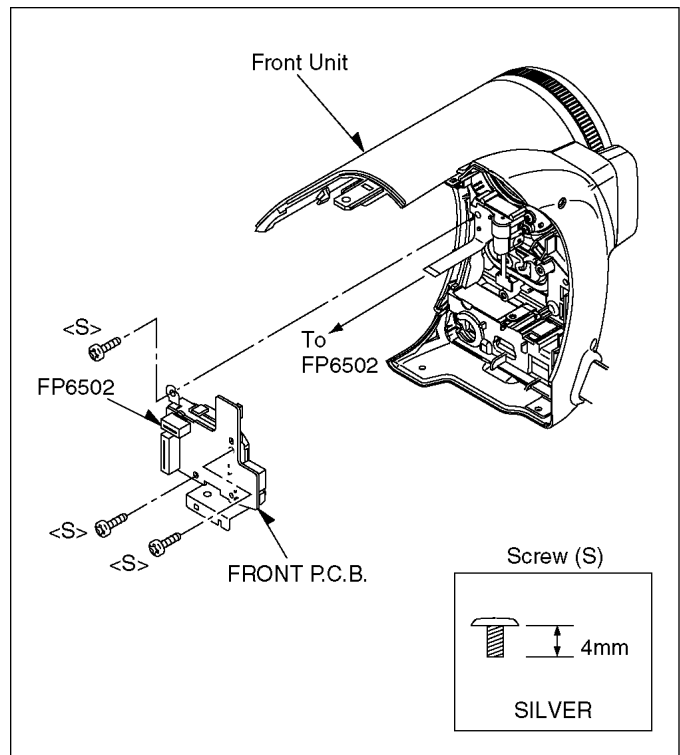

Fig. D16

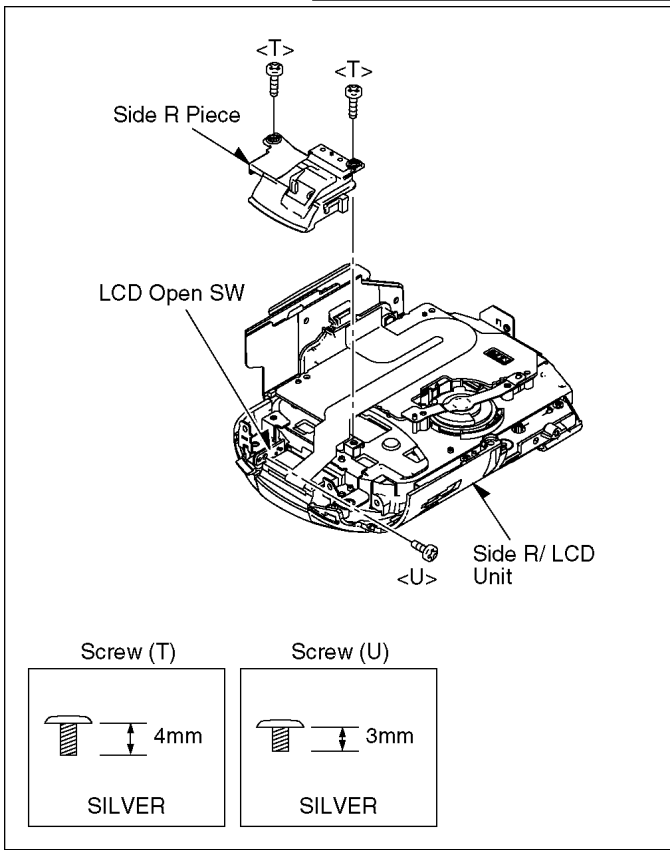

Fig. D17

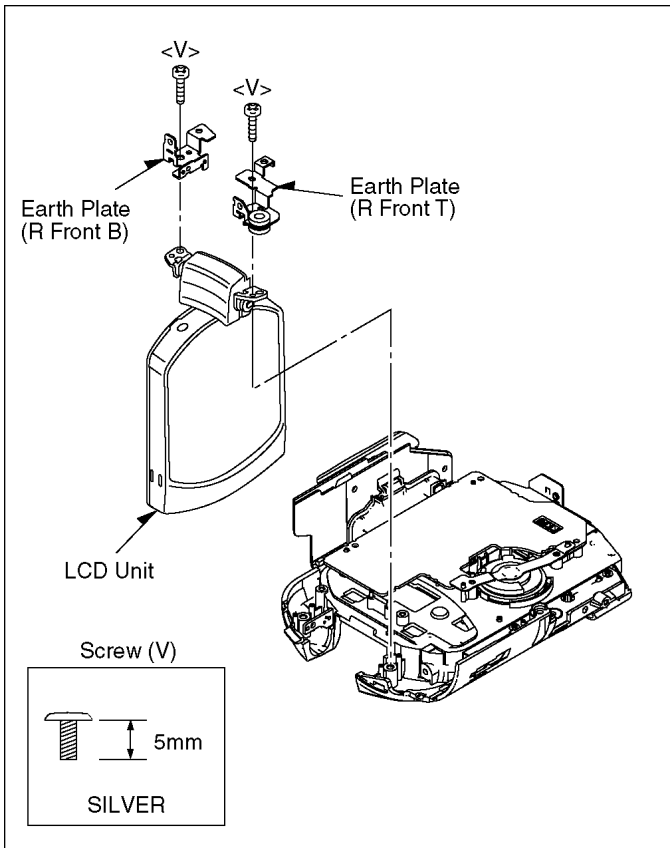

Fig. D18

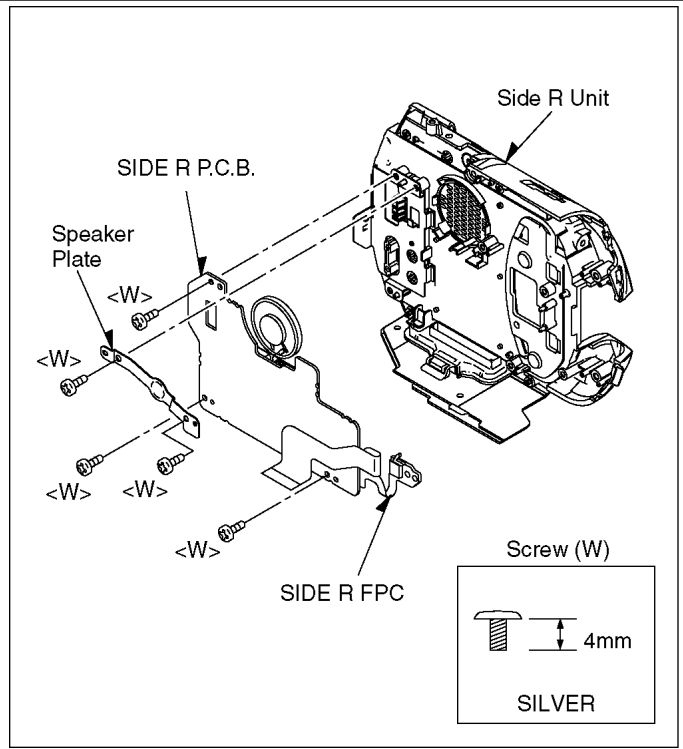

Fig. D19

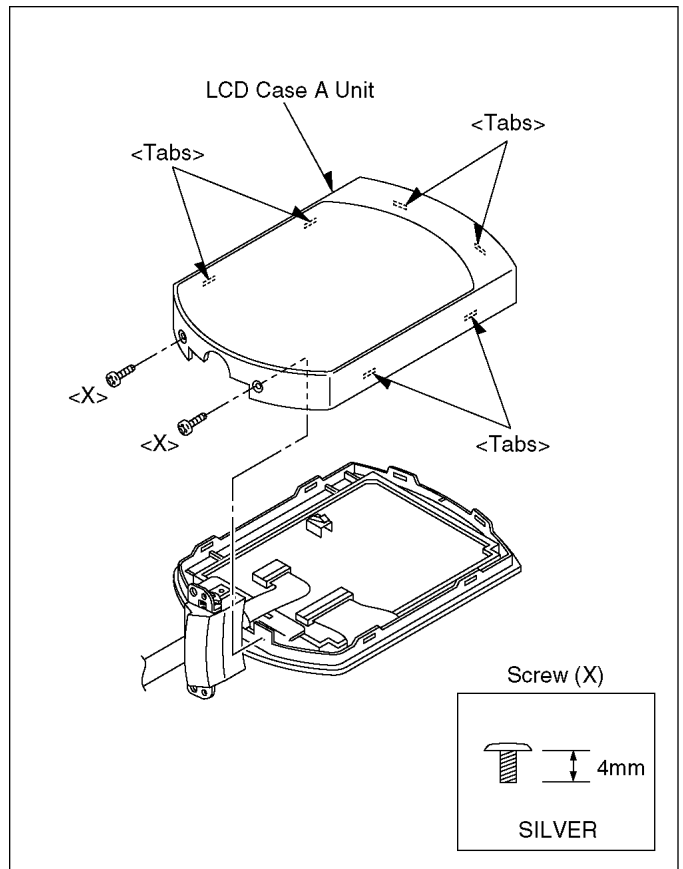

Fig. D20

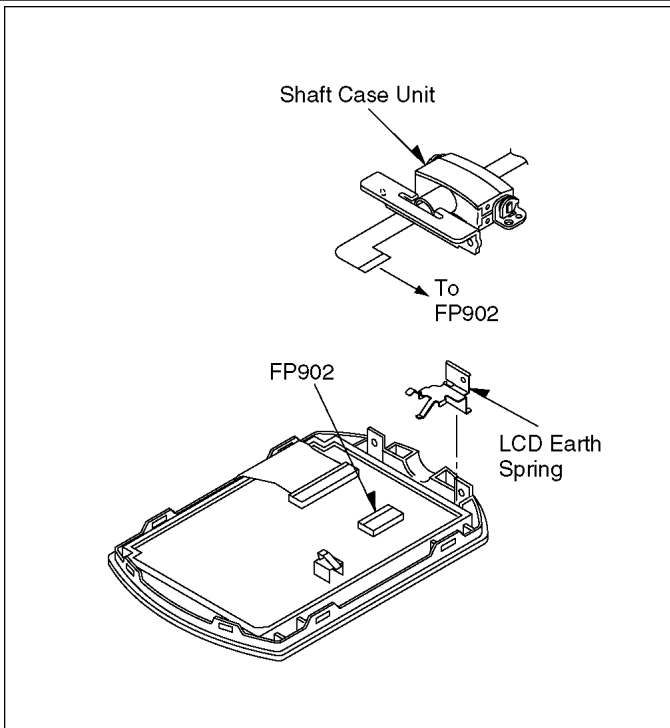

Fig. D21

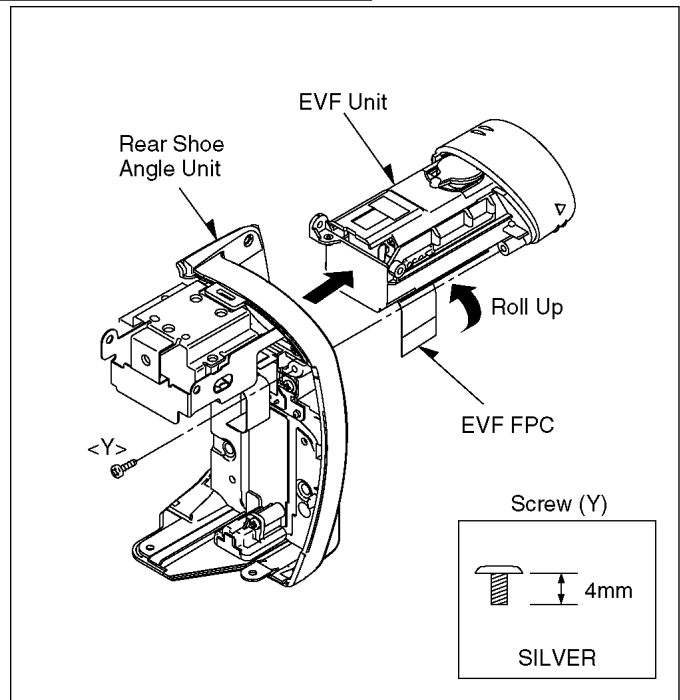

Fig. D23

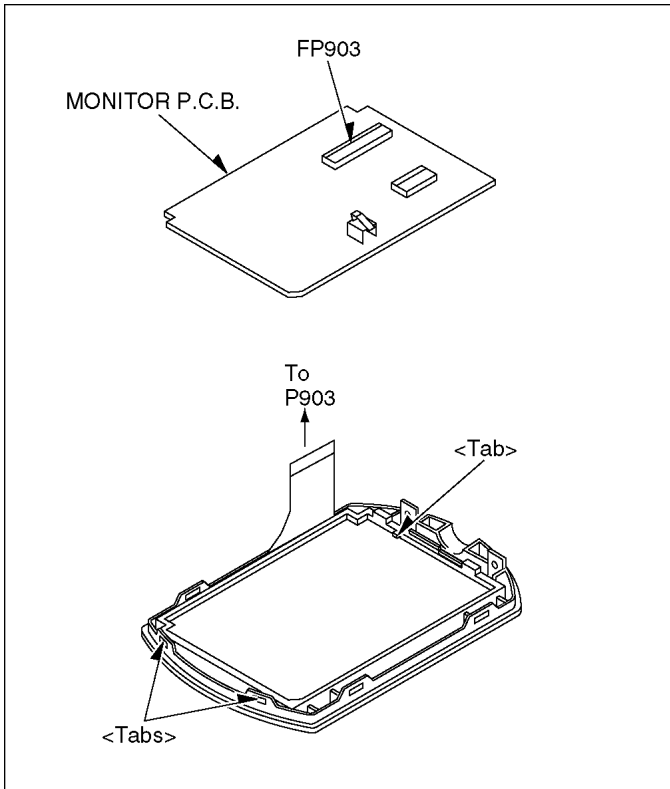

Fig. D22

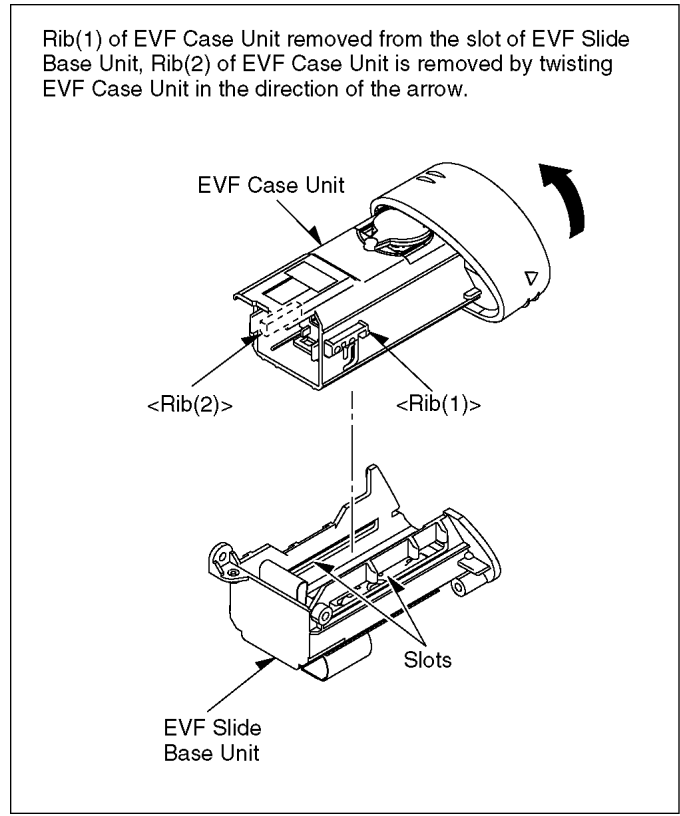

Fig. D24

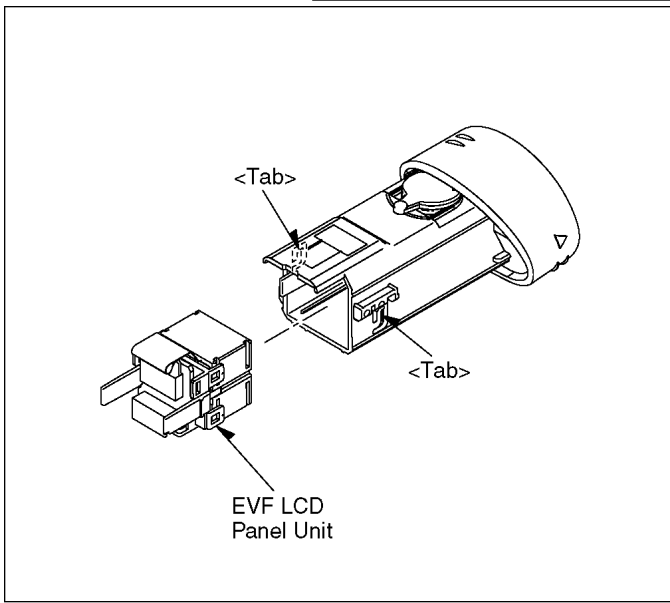

Fig. D25

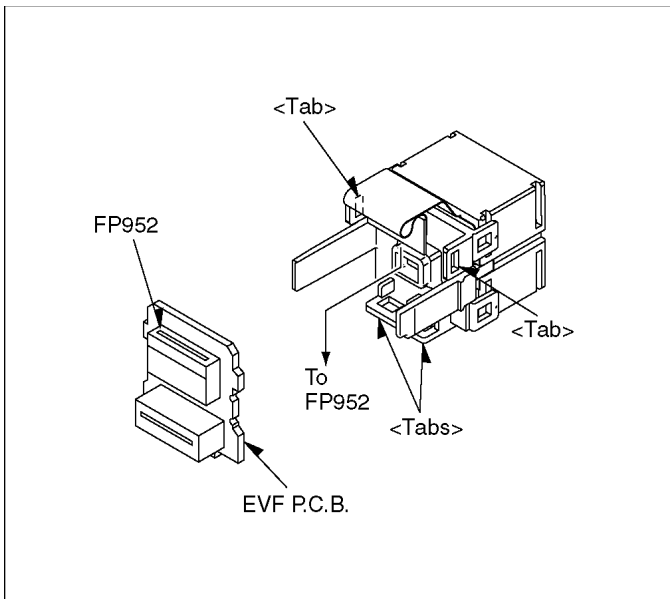

Fig. D26

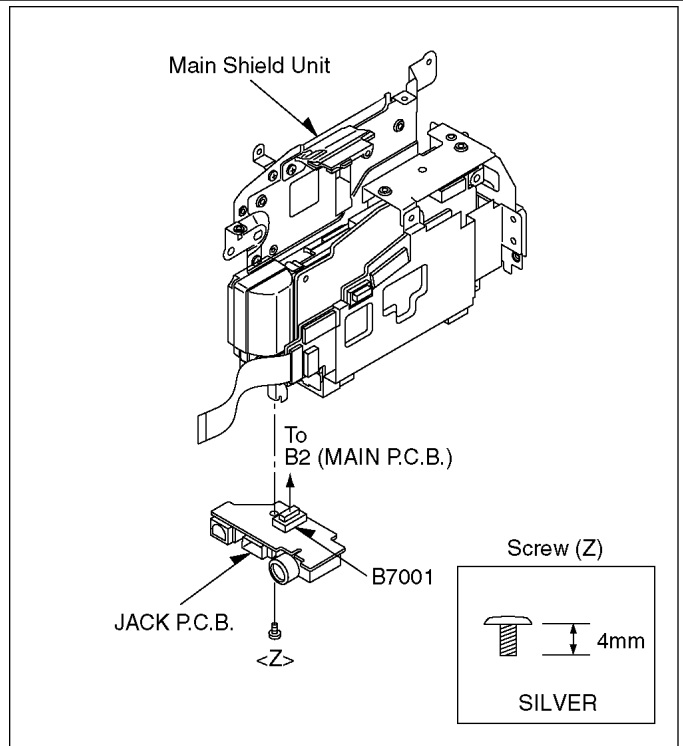

Fig. D27

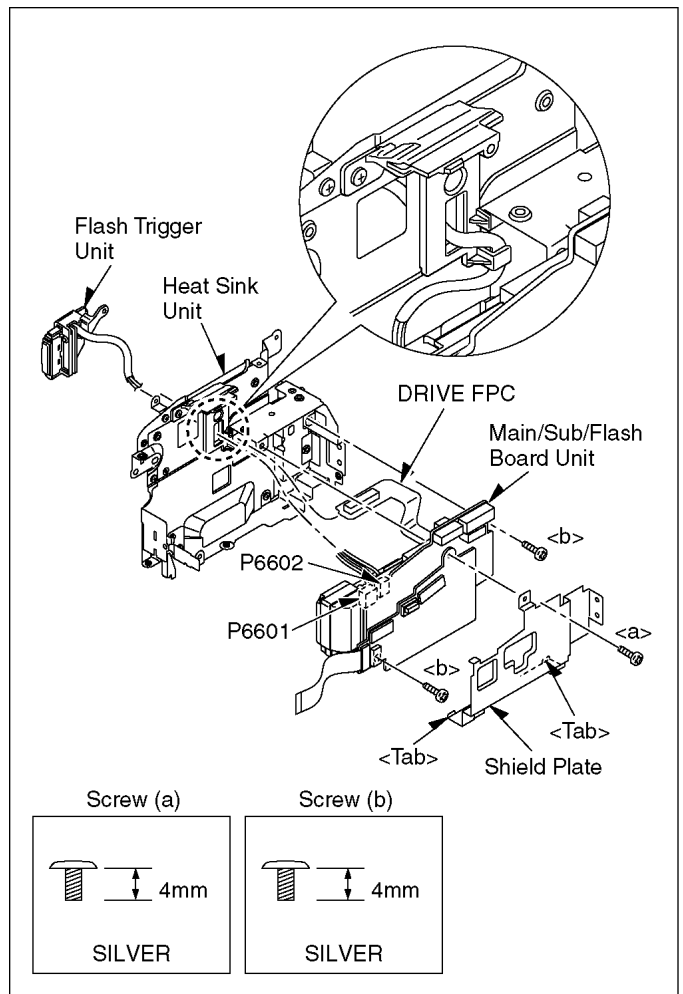

Fig. D28

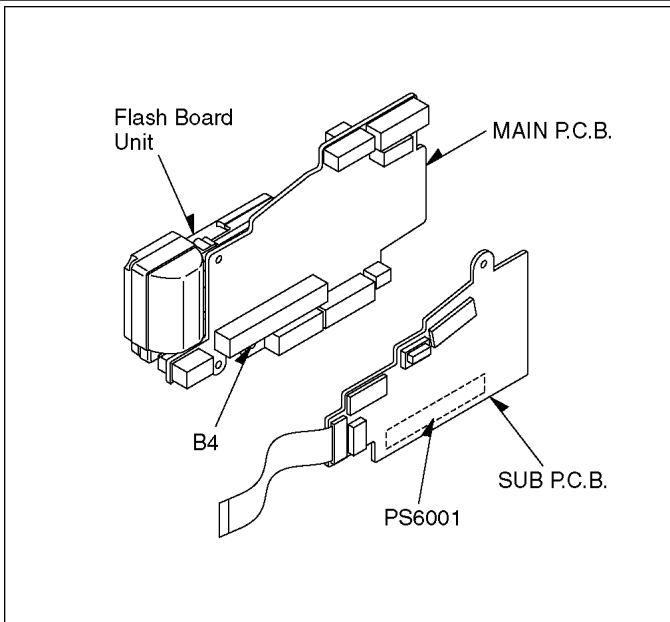

Fig. D29

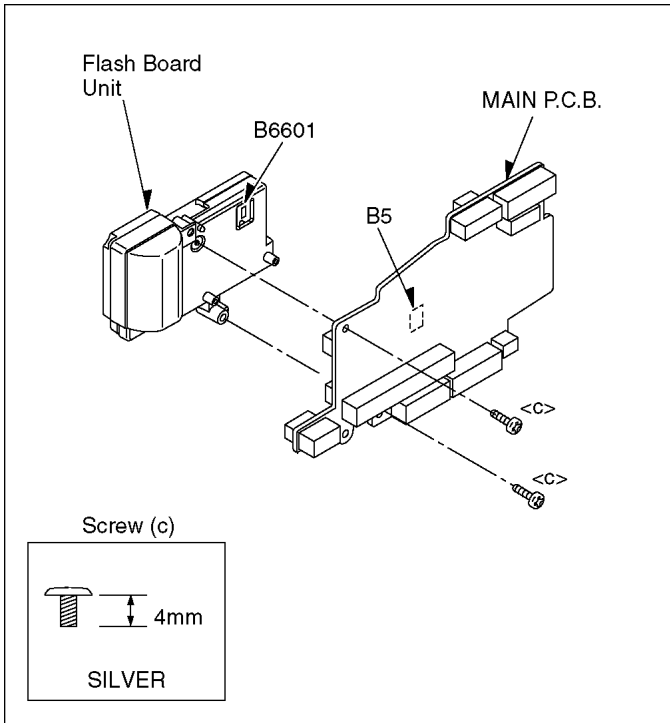
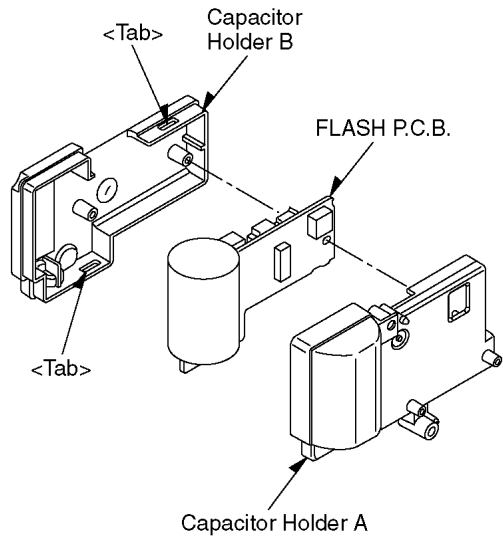

Fig. D30



**CAUTION**

**Be sure to discharge the capacitor on Flash P.C.B. before disassembling.**

**CAUTION**

**Be careful of the high voltage circuit on Flash P.C.B. when servicing.**

**Method:**

1. Prepare the 2 Resistors (ERG2SJ221:220 ohm /2w) for discharge.

**Note:**

2. Make short circuit using 2 Resistors between C6607(+) and C6607(-) for 3 seconds as follows.
3. After discharging, confirm that the capacitor voltage is sufficiently lowered using a voltmeter

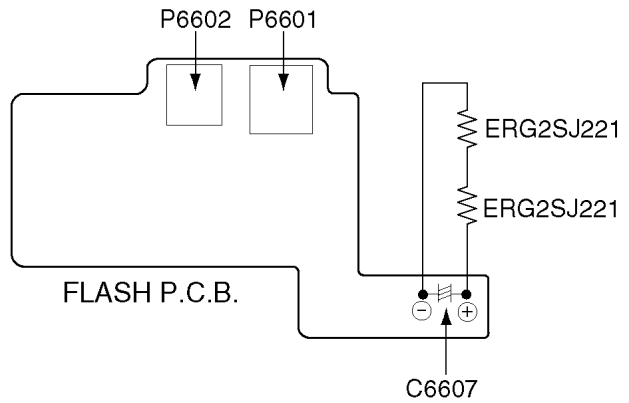

Fig. D31



## 9 Measurements and Adjustments

### 9.1. Service Positions

#### 9.1.1. List of the extension cables

Use the following extension cables when checking or adjusting individual circuit boards except module Parts (Main P.C.B. and Sub P.C.B.).

No.	Part No.	Part No.(sub)	Pin	Part Name	Connection	Q'ty
1	VFK1461	LSUA0020	20	Flat Cable	PS6003 (Sub) - FP6501 (Front)	1
2	VFK1440	---	10	Flat Cable	FP6502 (Front) - Barrier Motor Unit	1
4	VFK1492	---	26	Flat Cable	FP4 (Main) - FP902 (Monitor)	1
5	VFK1284	---	24	Flat Cable	FP1 (Main) - FP6301 (Side R)	1
6	VFK1286	---	16	Flat Cable	FP2 (Main) - Rear / Shoe Angle Unit	1
8	VFK1282	---	22	Flat Cable	FP5 (Main) - FP951 (EVF)	1
10	VFK1950	VFK1575C3320	33	Flat Cable	FP6002(Sub) - Lens Unit	1
11	VFK1459	---	39	Flat Cable	FP6001(Sub) - Prism Unit	1



### 9.1.2. Checking and repairing individual circuit boards except module parts (Main P.C.B. and Sub P.C.B.)

How to use extension cables.

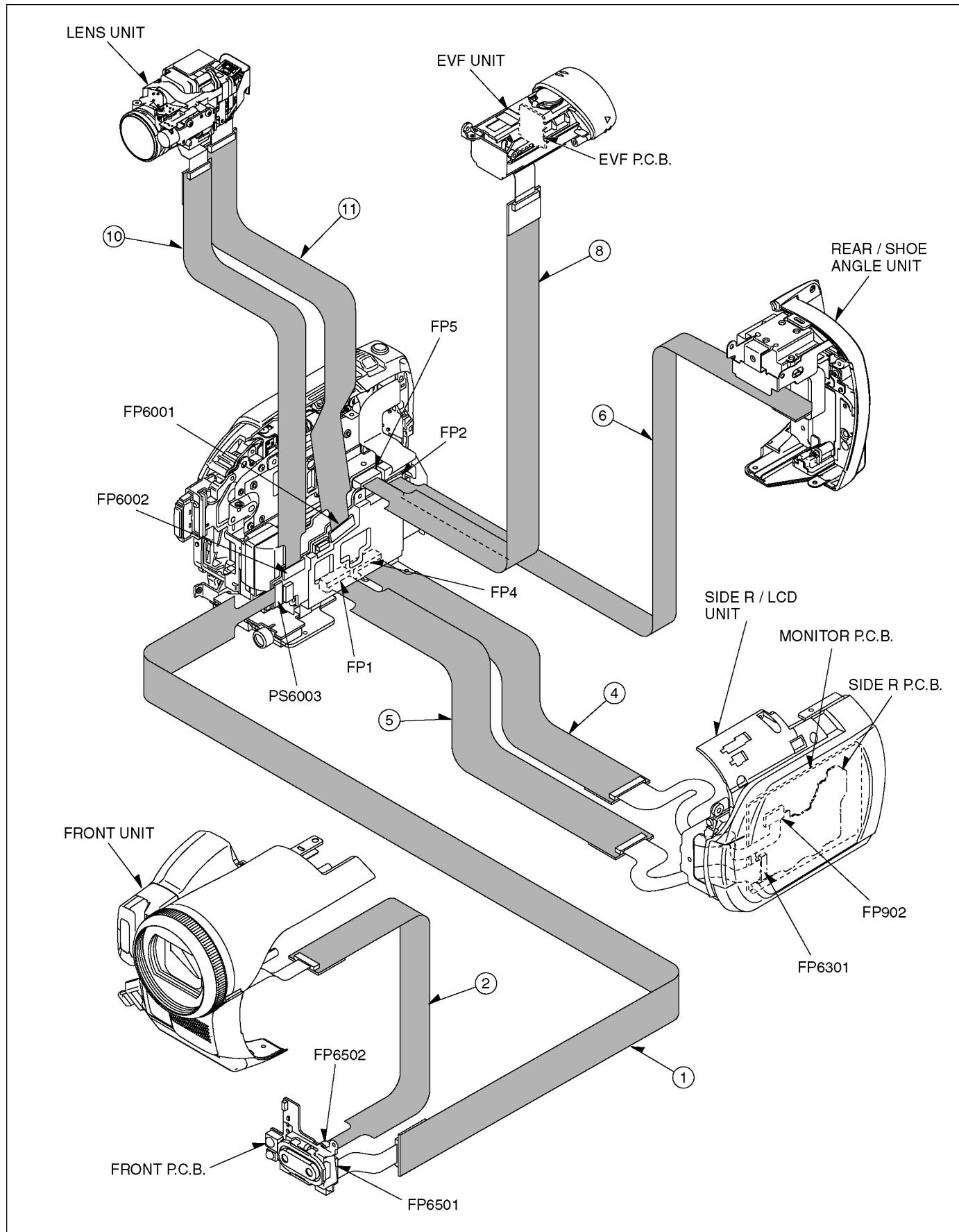

## 9.2. Location for Connectors of the Main P.C.B. & Sub P.C.B.

### 9.2.1. Main P.C.B.

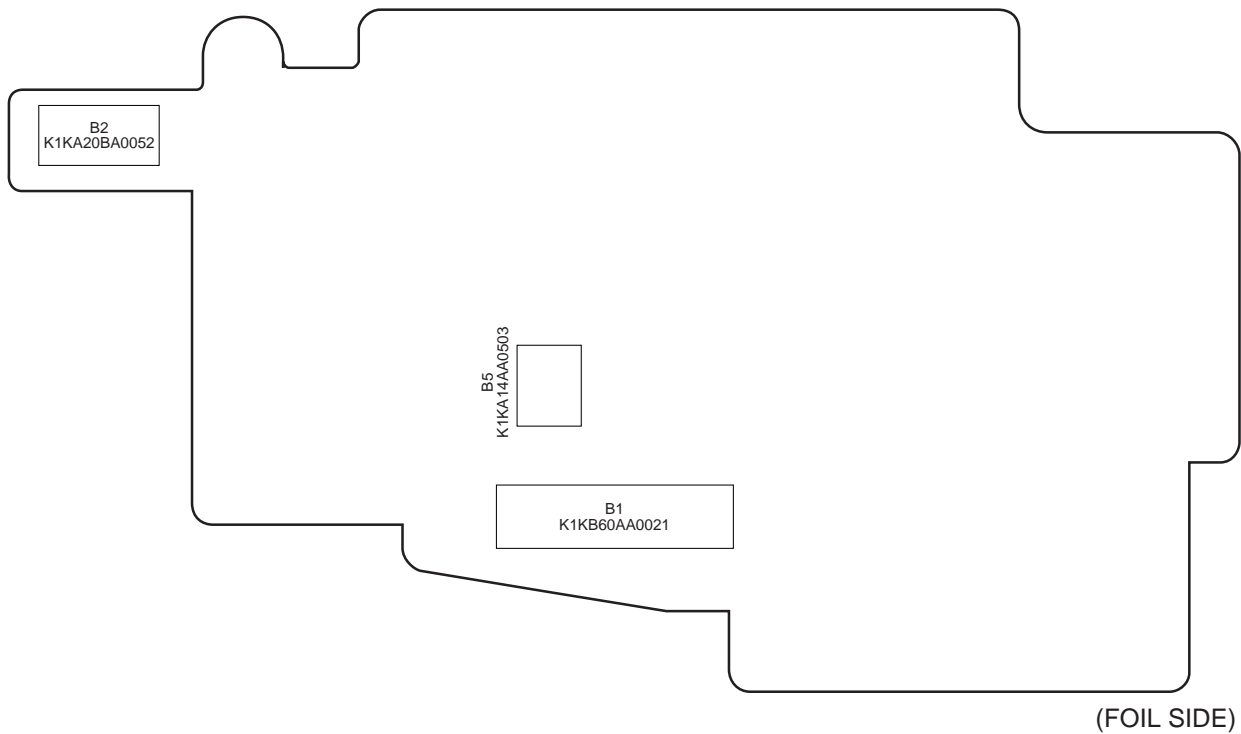
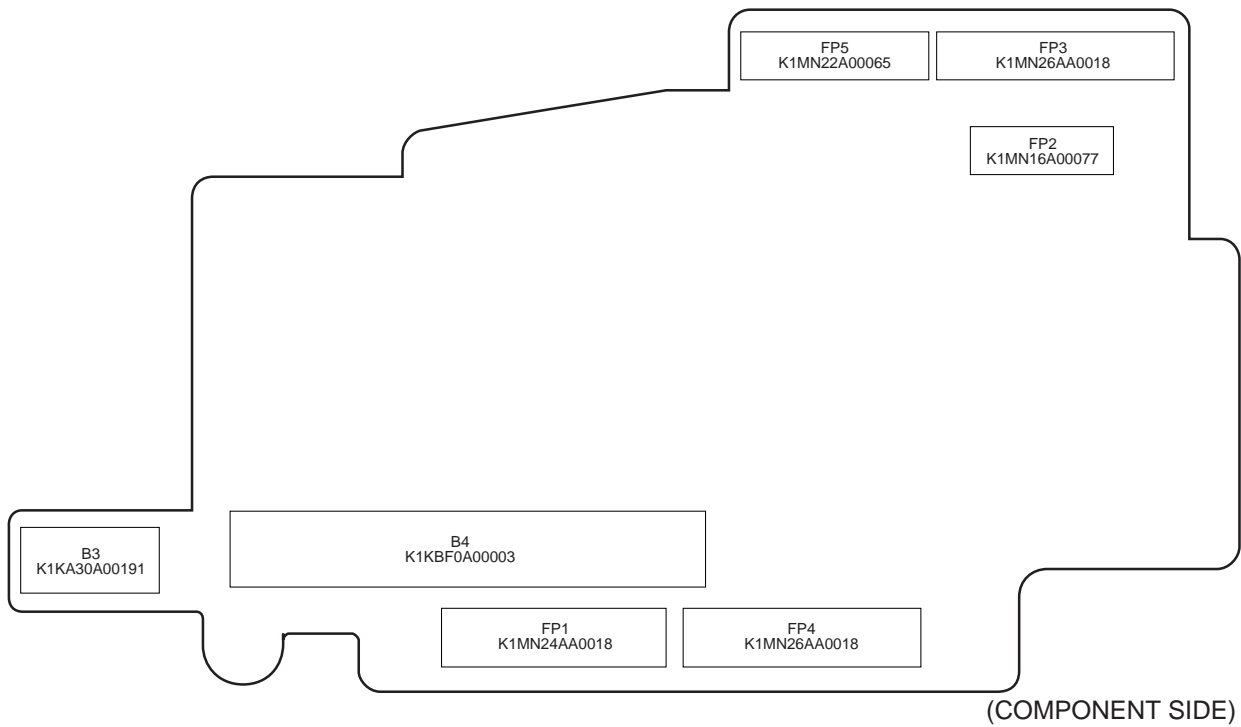

### 9.2.2. Sub P.C.B.

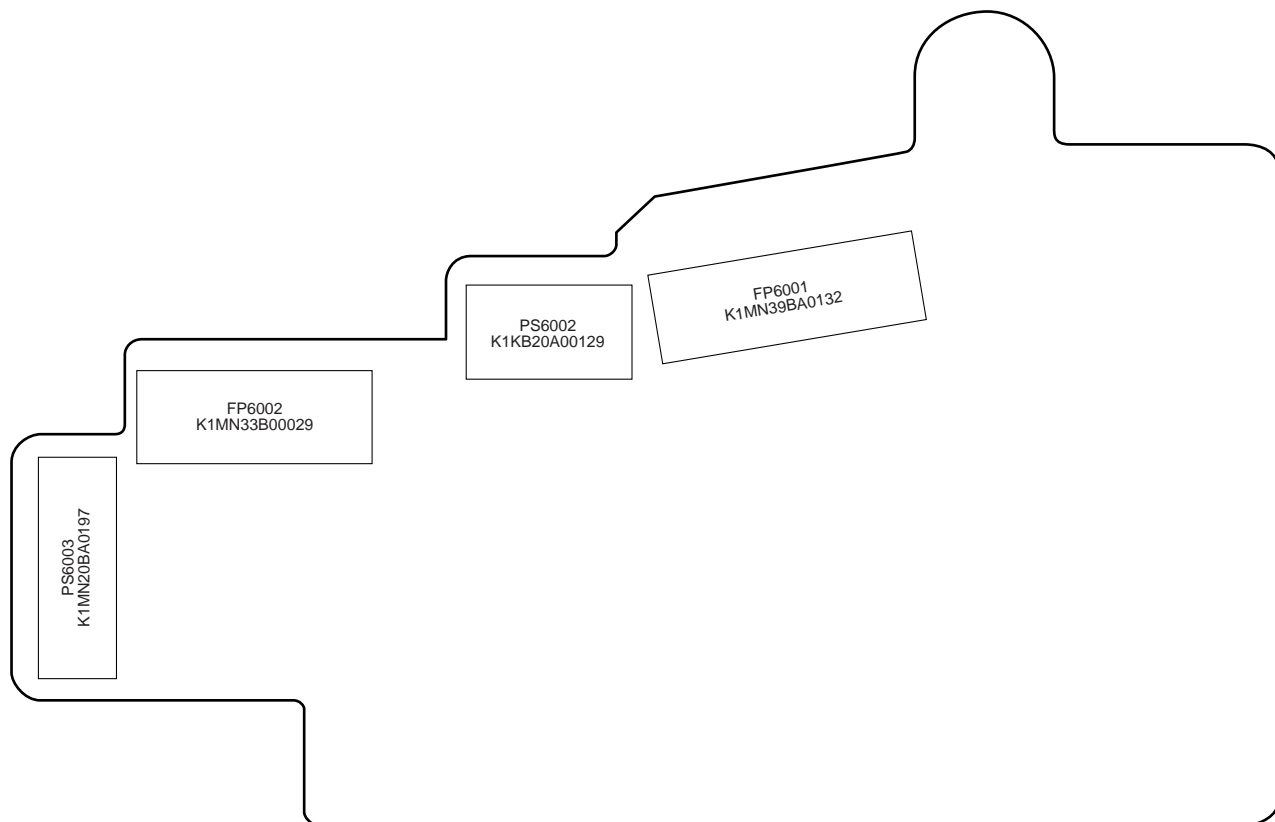

(COMPONENT SIDE)

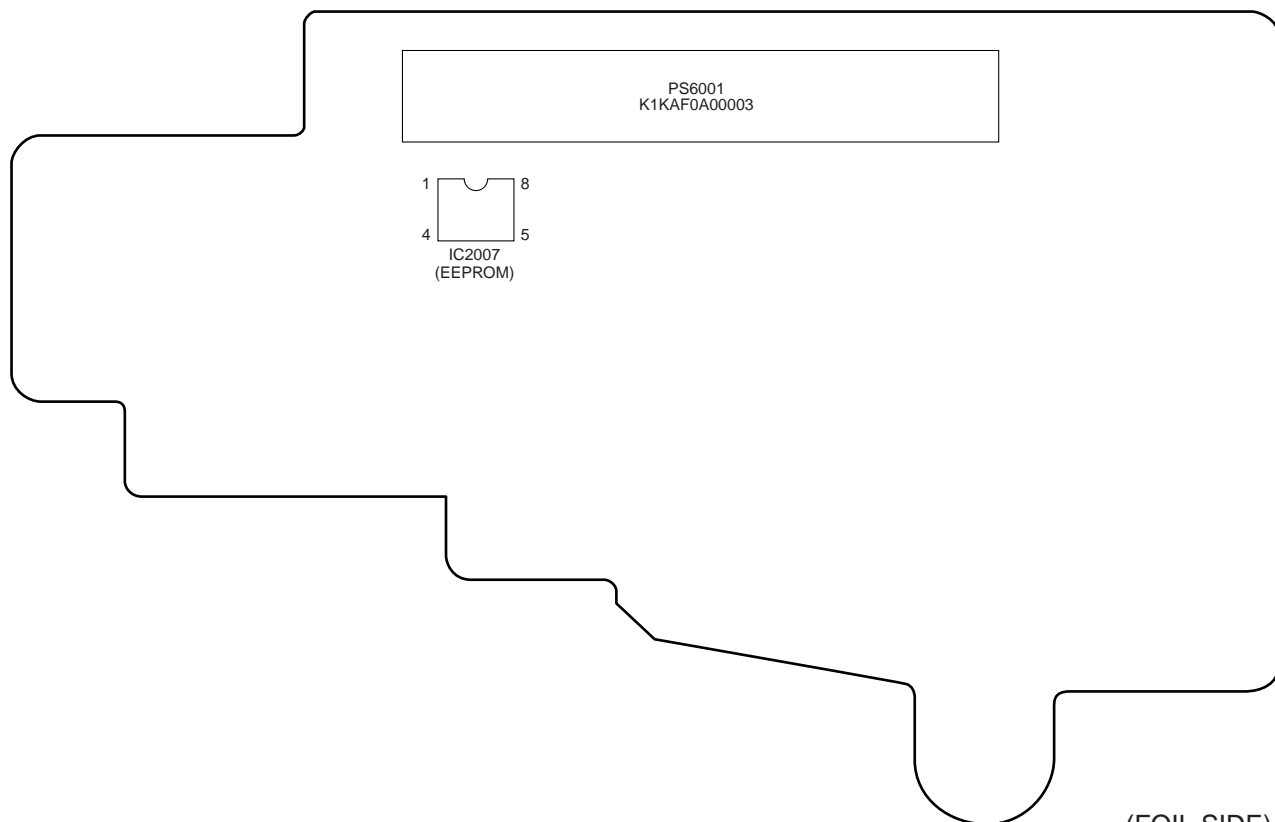

(FOIL SIDE)

## 9.3. Electrical Adjustment Procedures

### 9.3.1. Set-up manual for DVD Video Camera.

#### 1. Installation of USB-SERIAL Driver

Execute the "Setup.exe" file in "Com Mass" folder by double clicking to install the USB-SERIAL driver.

#### 2. Set-Up

a. Remove the card and disc from this unit.

b. To enter the PC connection (COM) mode, push the [DELETE] button, [RECORDING START/STOP] button and [JOYSTICK CONTROL UP] simultaneously for 3 seconds without connecting the USB Cable.

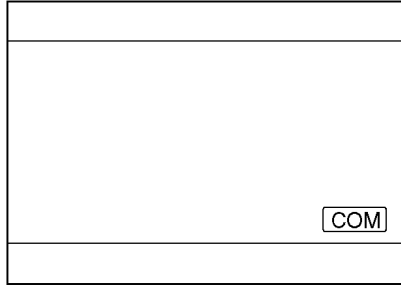

<LCD Monitor>

c. Connect the PC and DVD Video Camera as shown in Fig. E1 and E2.

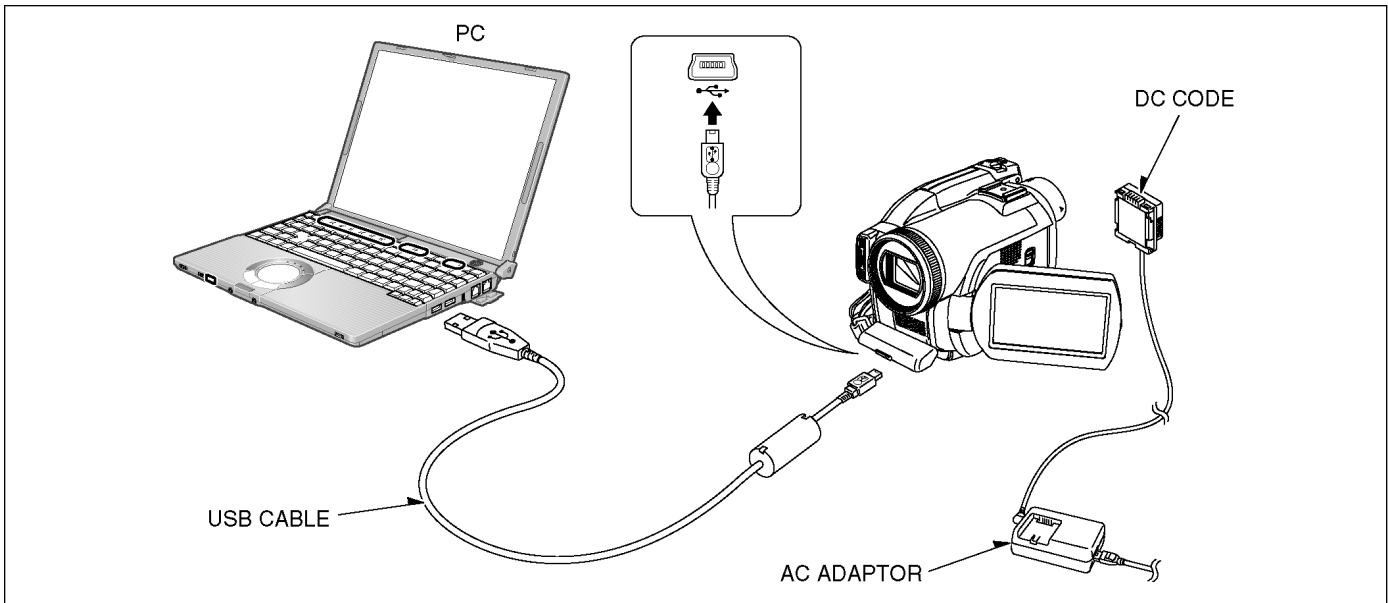

Fig. E1

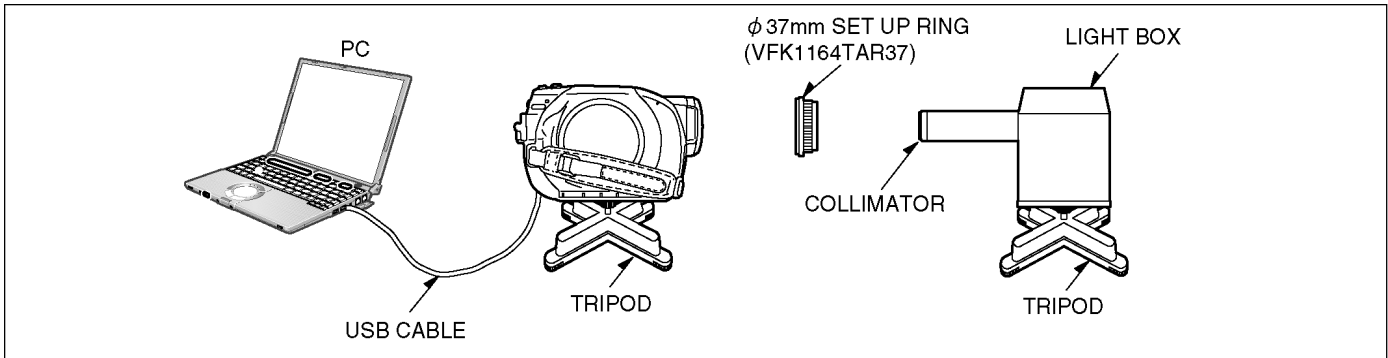

Fig. E2 Rough image of set-up connection

### 9.3.2. Set up PC-EVR adjustment program

1. Turn on the PC and install the PC-EVR Adjustment Program into the PC.
2. Execute the "kdr2006.exe" file by double clicking to start up the PC-EVR adjustment program.  
The main menu will be displayed.
3. Select the desired model.
4. Turn on the camcorder. Then, click "Start".

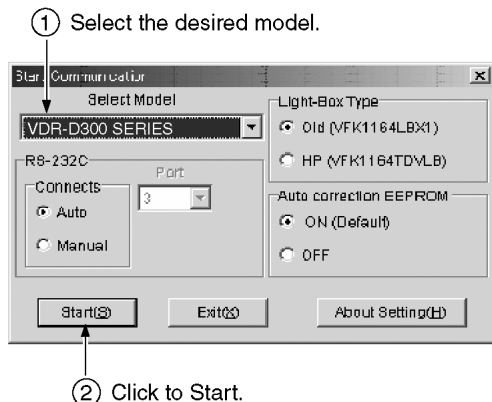

Fig. E3-1

5. The communication is complete, and the dialog will appear. Then, click "Cam" or "Arm" to save the EEPROM data.

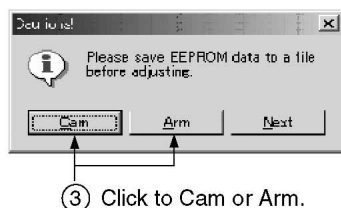

Fig. E3-2

6. Saving for EEPROM data is complete, menu will appear.  
To perform each adjustment, display the adjustment menu by selecting the desired menu from "Camera Adjust" or "Video Adjust" and select each adjustment item.



Fig. E3-3

**Note:**

The adjustment data is stored to the EEPROM IC after each adjustment.

7. After adjustment, to end the software, select "Exit" in File menu or close the window.

⑤ Select the Exit or close the window.

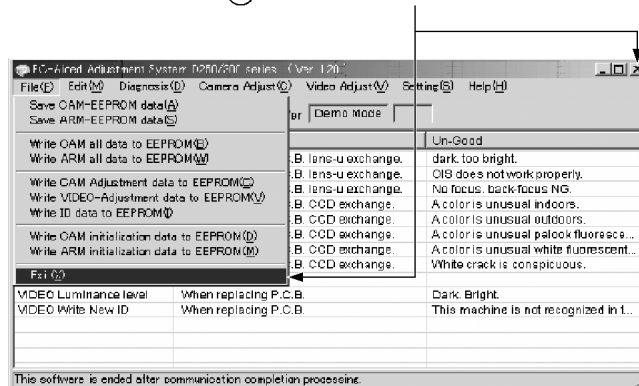

Fig. E3-4

8. To release the PC connection (COM) mode, push the [DELETE] button, [RECORDING START/STOP] button and [JOYSTICK CONTROL UP] simultaneously for 3 seconds without connecting the USB Cable.

### 9.3.3. Initial guideline

The table below shows which adjustments are necessary according to the unit parts and individual parts to be replaced. Make sure to perform these adjustments shown below as necessary.

Adjustment Item		Replacement Parts						
		Sub P.C.B.	Main P.C.B.	IC2007 (EEPROM)	Lens Unit	Prism Unit	Iris Unit	4th Lens Frame Unit
Camera	CAM hole amplifier / Iris PWM	○		○	○	○	○	
	CAM Tracking and De-focus	○		○	○	○	○	○
	CAM Revision CCD scratch	○		○	○	○	○	
	OIS HALL amplifier adjustment	○		○	○	○	○	
	CAM AWB adjustment	○		○	○	○	○	
Video	VCR Luminance level		○	○				

Note : ○ : Adjustment Item

# 10 Maintenance

## 10.1. Cleaning Lens, Viewfinder and LCD Panel

Do not touch the surface of the lens, Viewfinder and LCD Panel with your hand.

When cleaning the lens, use air-Blower to blow off the dust.

When cleaning the LCD Panel, dampen the lens cleaning paper with lens cleaner, and the gently wipe the their surface.

**Note:**

A lens cleaning paper and lens cleaner are available at local camera shops and market place.

## 10.2. Cleaning Disc

1. Use the provided disc cleaning cloth, or soft and dry cloth to lightly clean the disc from the inner to outer edges in axial direction.
2. If the dirt cannot be removed with the above procedure, put a few droplets of absolute alcohol in a soft and dry cloth, and use it to lightly clean the disc from the inner to outer edges in axial direction.

Disc cleaning cloth provided  
or soft and dry cloth

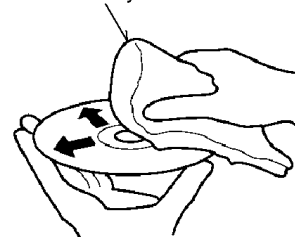

CLEANING DISC

## 10.3. Cleaning optical pickup

**Note:**

Do not clean the optical pickup needlessly. The optical pickup is a precision component. Repeated cleaning could cause a fault.

1. Attach the AC adapter/charger or battery (power supply), and then slide the DISC EJECT switch to open the disc insertion block.
2. Remove the AC adapter/charger or battery (power supply).

**Caution:**

Laser light striking the eye may cause your eyesight to be lost : For safety, be sure to remove any power supply (AC adaptor/charger, battery, etc.) from the DVD video camera/recorder before starting work.

<CSA requirement>

**CAUTION: VISIBLE LASER RADIATION DO NOT STARE INTO THE BEAM OR VIEW DIRECTLY WITH OPTICAL INSTRUMENTS CLASS 2M**

3. Check to see whether the optical pickup is dirty. If it is not dirty, use the following procedure to clean it:

- a. Apply one drop of absolute alcohol on a clean cotton swab (\*1).

Lens cleaner liquid for CD/DVD (generally available) may be substituted for absolute alcohol.

- b. Lightly swab the optical pickup to clean it.

Using too much force during cleaning may cause a fault to occur.

\*1: Always use a fresh cotton swab free from any additive or chemical.

OPTICAL PICKUP

COTTON SWAB



TURNTABLE

CLEANING OPTICAL PICKUP



# 11 Schematic Diagrams

## 11.1. OVERALL SCHEMATIC DIAGRAM

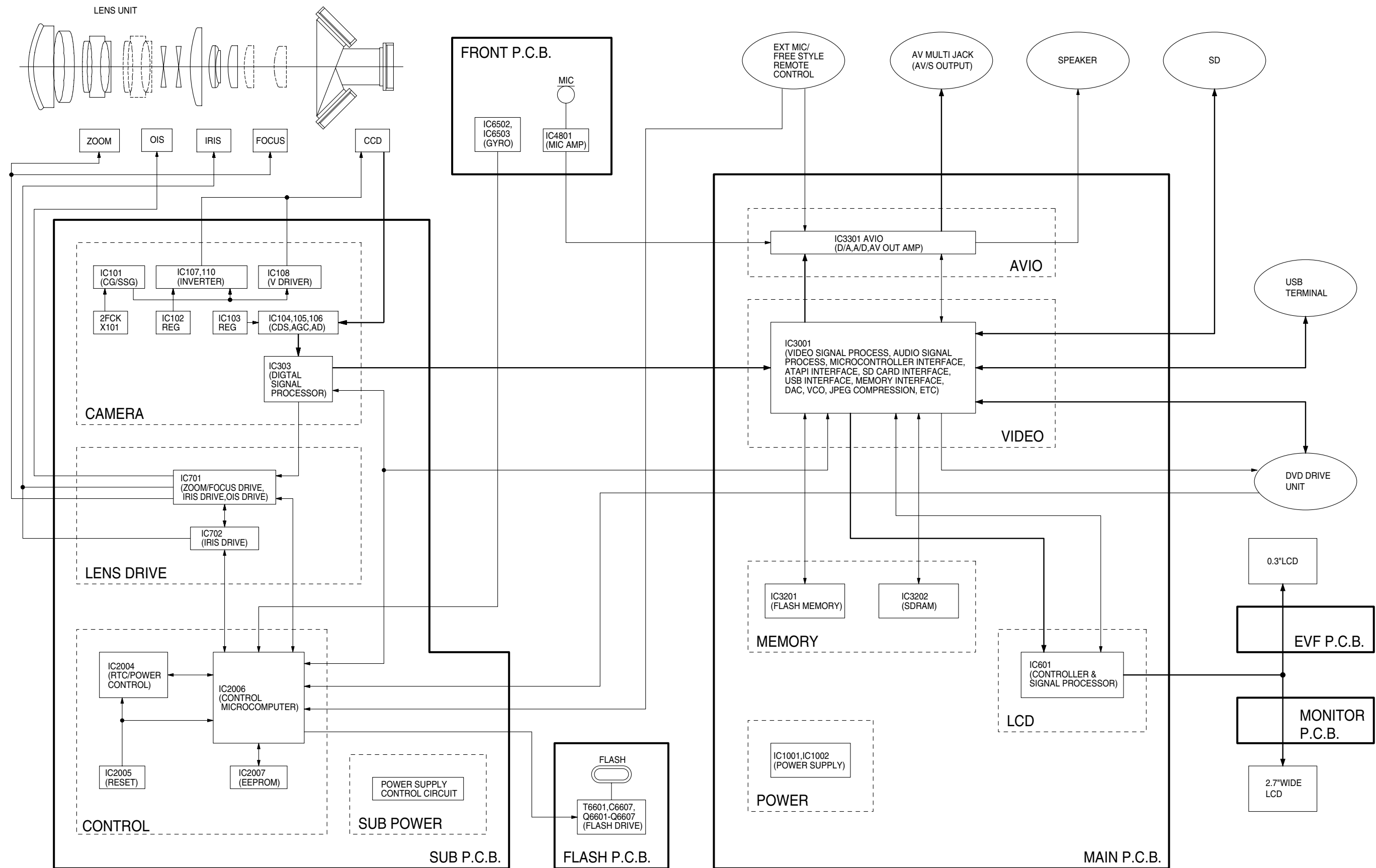

VDR-D300,D308  
OVERALL SCHEMATIC DIAGRAM

# 11.2. INTERCONNECTION SCHEMATIC DIAGRAM

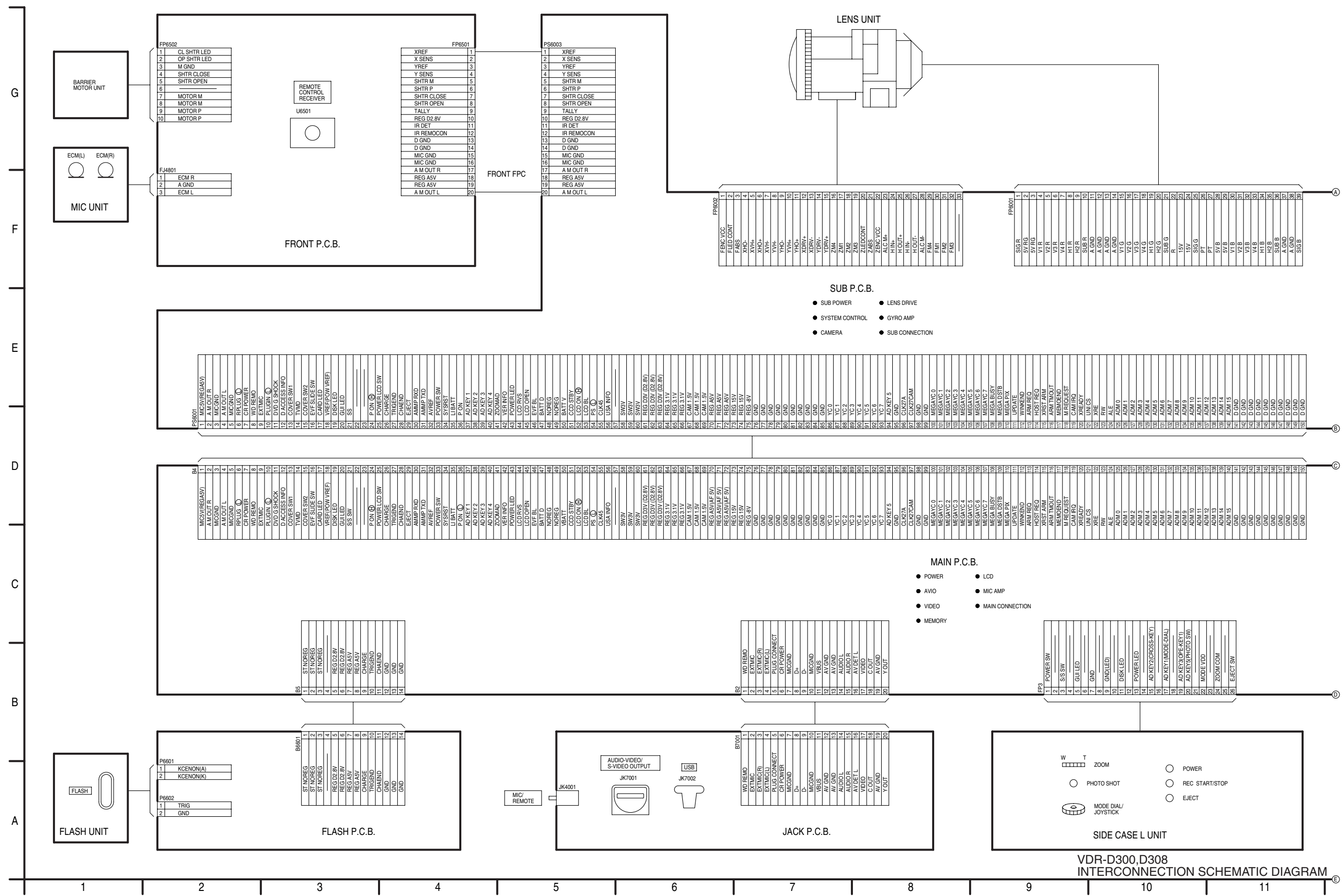



### 11.3. FLASH SCHEMATIC DIAGRAM

(FLASH P.C.B.)

NOTE:  
DO NOT USE ANY PART NUMBER SHOWN ON  
THIS SCHEMATIC DIAGRAM FOR ORDERING.  
WHEN YOU ORDER A PART, PLEASE REFER  
TO PARTS LIST.

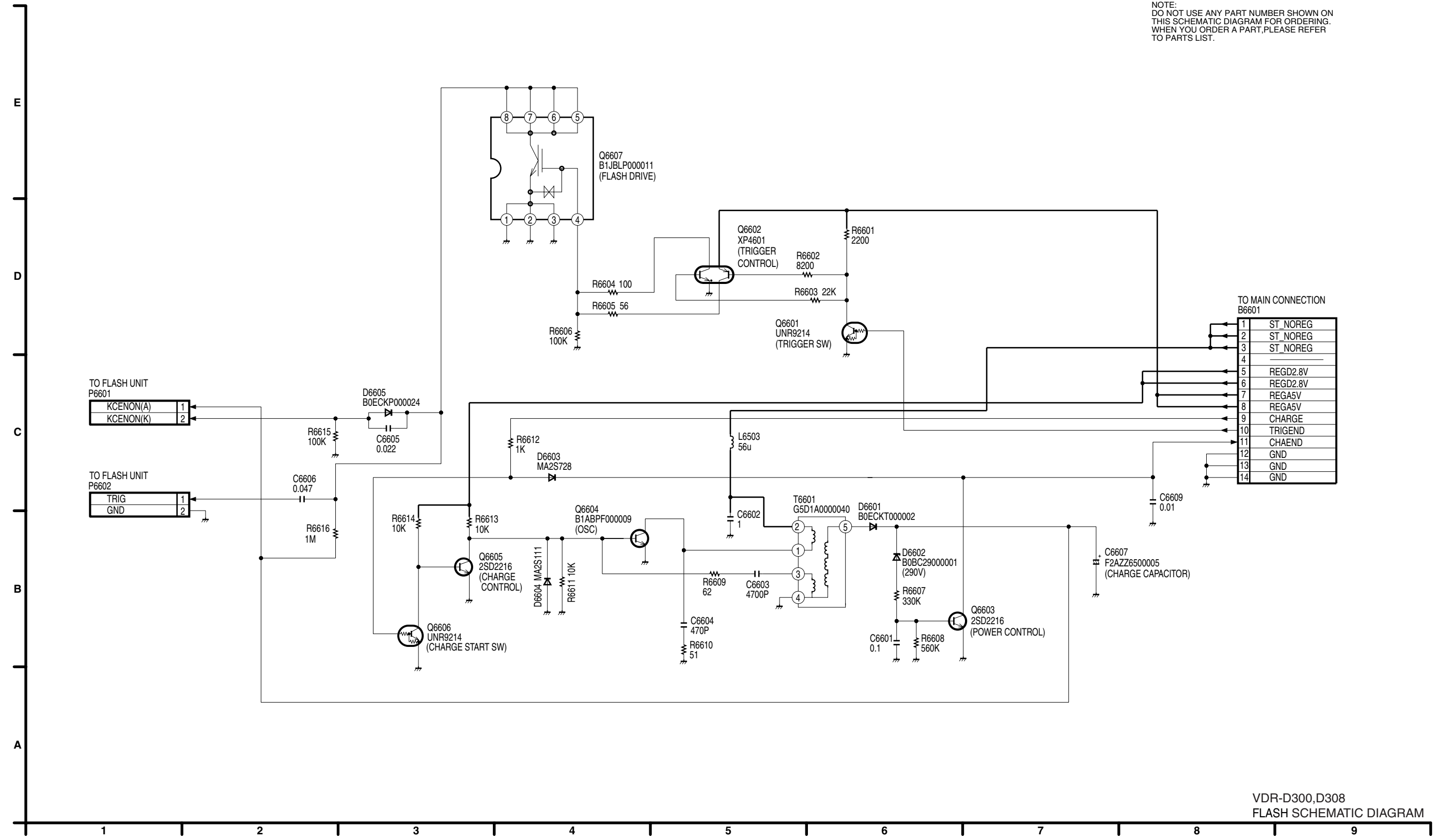

VDR-D300,D308  
FLASH SCHEMATIC DIAGRAM

# 11.4. FRONT SCHEMATIC DIAGRAM

(FRONT P.C.B.)

NOTE:  
DO NOT USE ANY PART NUMBER SHOWN ON THIS SCHEMATIC DIAGRAM FOR ORDERING. WHEN YOU ORDER A PART, PLEASE REFER TO PARTS LIST.

NOTE:  
THE MEASUREMENT MODE OF THE DC VOLTAGE ON THIS DIAGRAM IS STOP MODE.

NOTE:  
CIRCUIT VOLTAGE AND WAVEFORM DESCRIBED HEREIN SHALL BE REGARDED AS REFERENCE INFORMATION WHEN PROBING DEFECT POINT, BECAUSE IT MAY DIFFER FROM AN ACTUAL MEASURING VALUE DUE TO DIFFERENCE OF MEASURING INSTRUMENT AND ITS MEASURING CONDITION AND PRODUCT ITSELF.

➡ : AUDIO MAIN SIGNAL PATH IN REC MODE

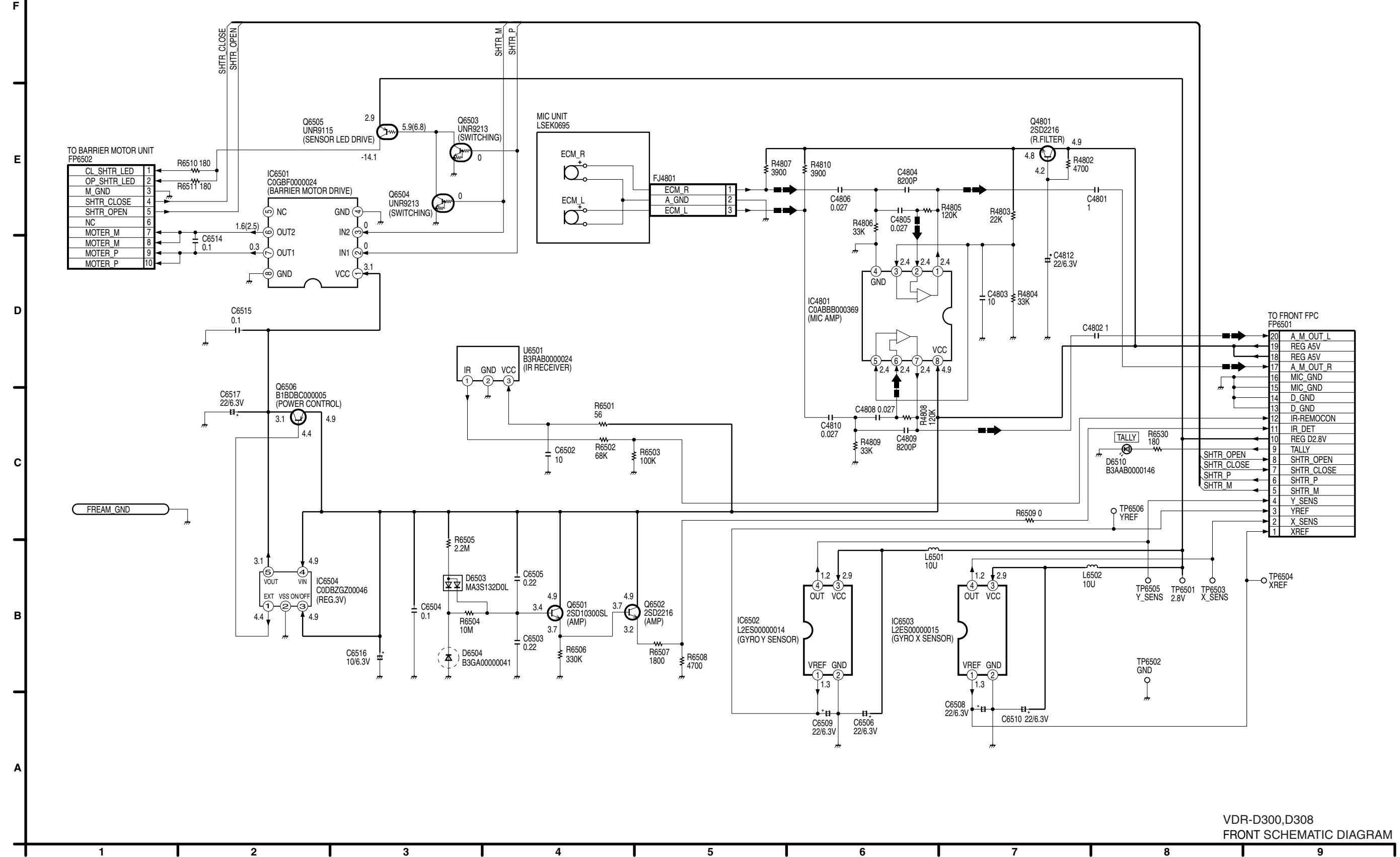

VDR-D300,D308  
FRONT SCHEMATIC DIAGRAM

# 11.5. SIDE R SCHEMATIC DIAGRAM

(SIDE R P.C.B.)

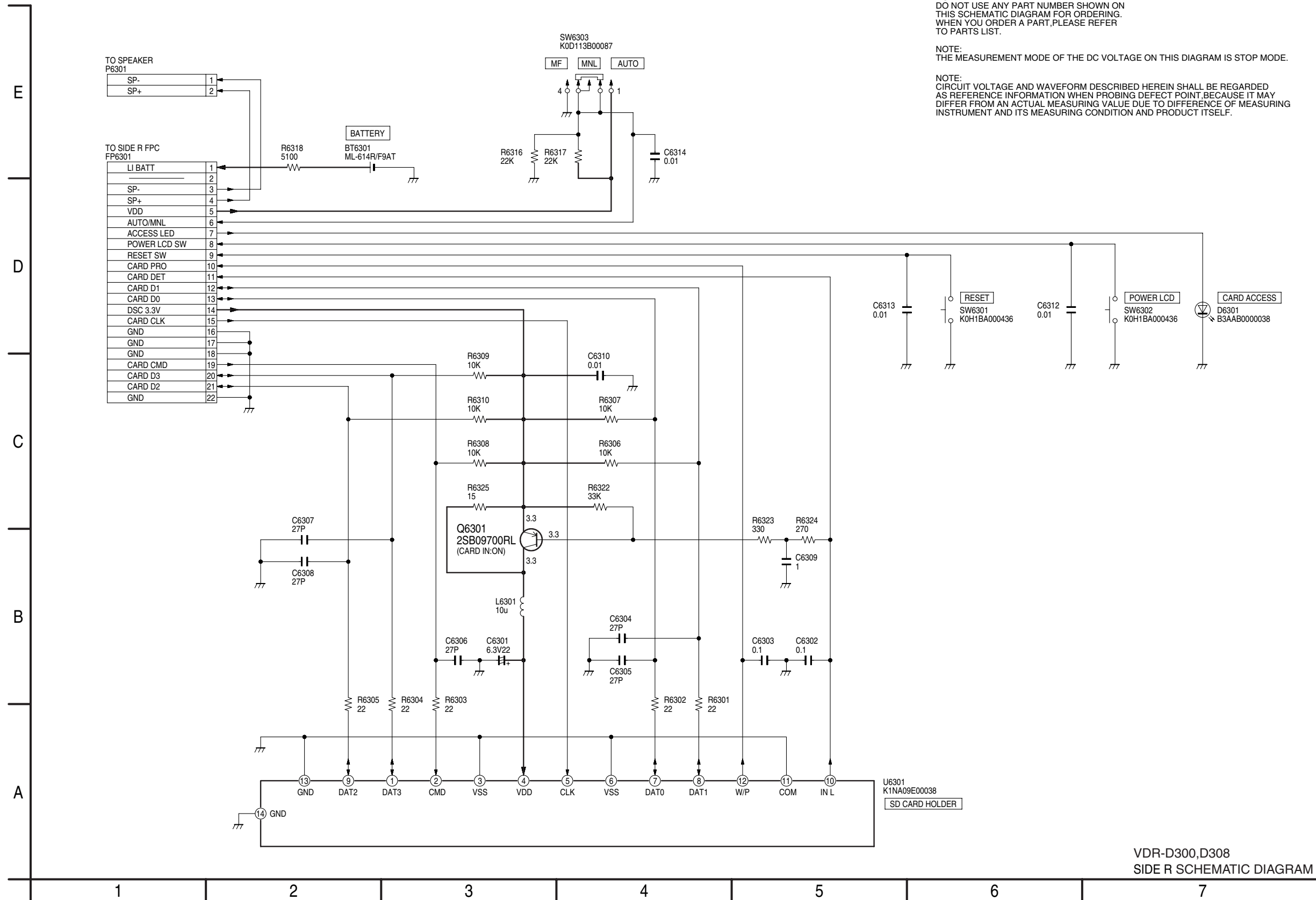

NOTE:  
DO NOT USE ANY PART NUMBER SHOWN ON THIS SCHEMATIC DIAGRAM FOR ORDERING. WHEN YOU ORDER A PART, PLEASE REFER TO PARTS LIST.

NOTE:  
THE MEASUREMENT MODE OF THE DC VOLTAGE ON THIS DIAGRAM IS STOP MODE.

NOTE:  
CIRCUIT VOLTAGE AND WAVEFORM DESCRIBED HEREIN SHALL BE REGARDED AS REFERENCE INFORMATION WHEN PROBING DEFECT POINT, BECAUSE IT MAY DIFFER FROM AN ACTUAL MEASURING VALUE DUE TO DIFFERENCE OF MEASURING INSTRUMENT AND ITS MEASURING CONDITION AND PRODUCT ITSELF.

VDR-D300,D308  
SIDE R SCHEMATIC DIAGRAM

# 11.6. MONITOR SCHEMATIC DIAGRAM

(MONITOR P.C.B.)

F  
E  
D  
C  
B  
A

NOTE:  
DO NOT USE ANY PART NUMBER SHOWN ON THIS SCHEMATIC DIAGRAM FOR ORDERING. WHEN YOU ORDER A PART, PLEASE REFER TO PARTS LIST.

NOTE:  
THE MEASUREMENT MODE OF THE DC VOLTAGE ON THIS DIAGRAM IS STOP MODE.(MONITOR:ON)

NOTE:  
CIRCUIT VOLTAGE AND WAVEFORM DESCRIBED HEREIN SHALL BE REGARDED AS REFERENCE INFORMATION WHEN PROBING DEFECT POINT, BECAUSE IT MAY DIFFER FROM AN ACTUAL MEASURING VALUE DUE TO DIFFERENCE OF MEASURING INSTRUMENT AND ITS MEASURING CONDITION AND PRODUCT ITSELF.

➔ : VIDEO MAIN SIGNAL PATH

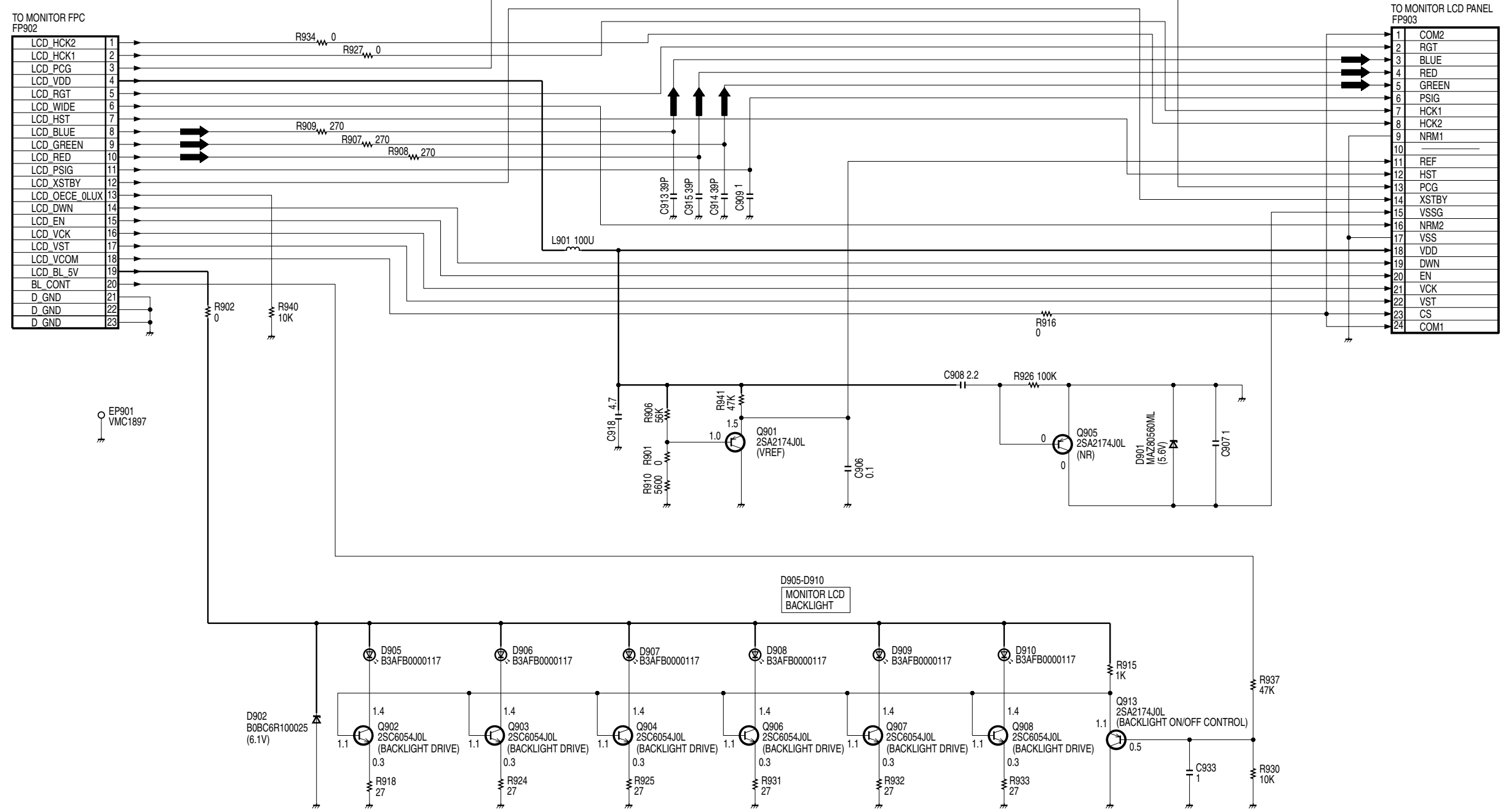

VDR-D300,D308  
MONITOR SCHEMATIC DIAGRAM

### 11.7. JACK SCHEMATIC DIAGRAM

(JACK P.C.B.)

NOTE:  
DO NOT USE ANY PART NUMBER SHOWN ON THIS SCHEMATIC DIAGRAM FOR ORDERING. WHEN YOU ORDER A PART, PLEASE REFER TO PARTS LIST.

- ➡ : VIDEO MAIN SIGNAL PATH IN REC MODE
- ➡ : VIDEO MAIN SIGNAL PATH IN PLAYBACK MODE
- ➡ : AUDIO MAIN SIGNAL PATH IN REC MODE
- ➡ : AUDIO MAIN SIGNAL PATH IN PLAYBACK MODE

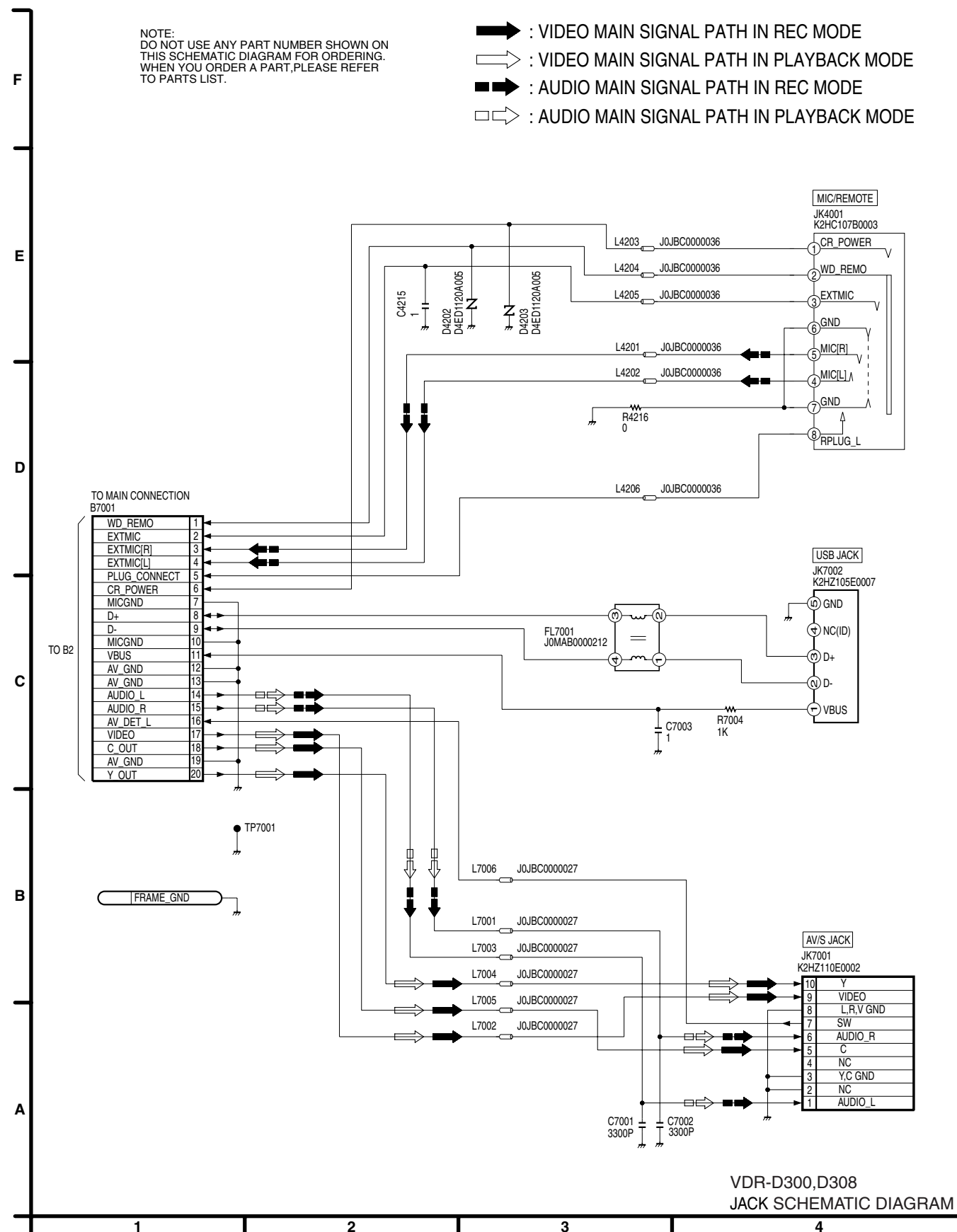

### 11.8. EVF SCHEMATIC DIAGRAM

(EVF P.C.B.)

NOTE:  
DO NOT USE ANY PART NUMBER SHOWN ON THIS SCHEMATIC DIAGRAM FOR ORDERING. WHEN YOU ORDER A PART, PLEASE REFER TO PARTS LIST.

NOTE:  
THE MEASUREMENT MODE OF THE DC VOLTAGE ON THIS DIAGRAM IS STOP MODE.(EVF:ON)  
NOTE:  
CIRCUIT VOLTAGE AND WAVEFORM DESCRIBED HEREIN SHALL BE REGARDED AS REFERENCE INFORMATION WHEN PROBING DEFECT POINT, BECAUSE IT MAY DIFFER FROM AN ACTUAL MEASURING VALUE DUE TO DIFFERENCE OF MEASURING INSTRUMENT AND ITS MEASURING CONDITION AND PRODUCT ITSELF.

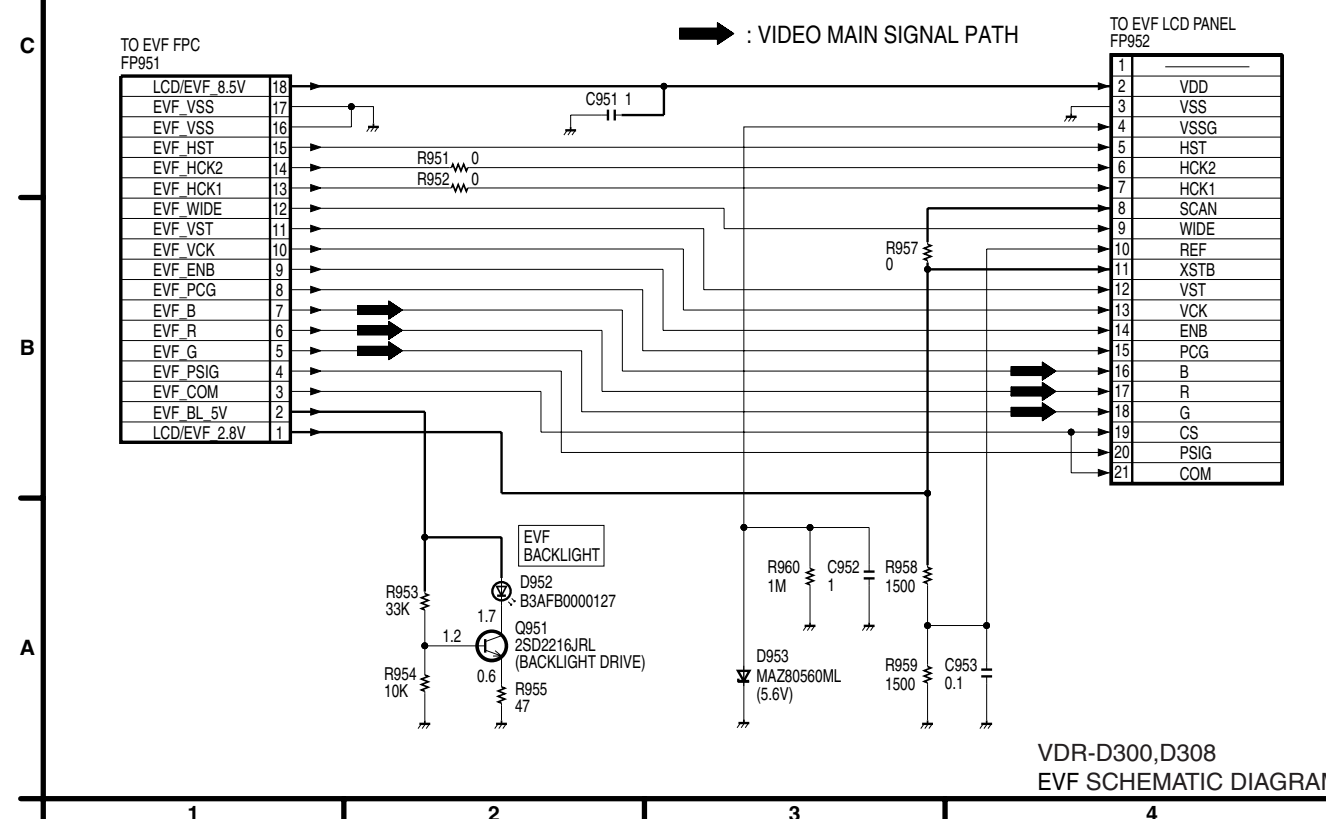

### 11.9. EVF FPC SCHEMATIC DIAGRAM

(EVF FPC)

" FOR REFERENCE ONLY "

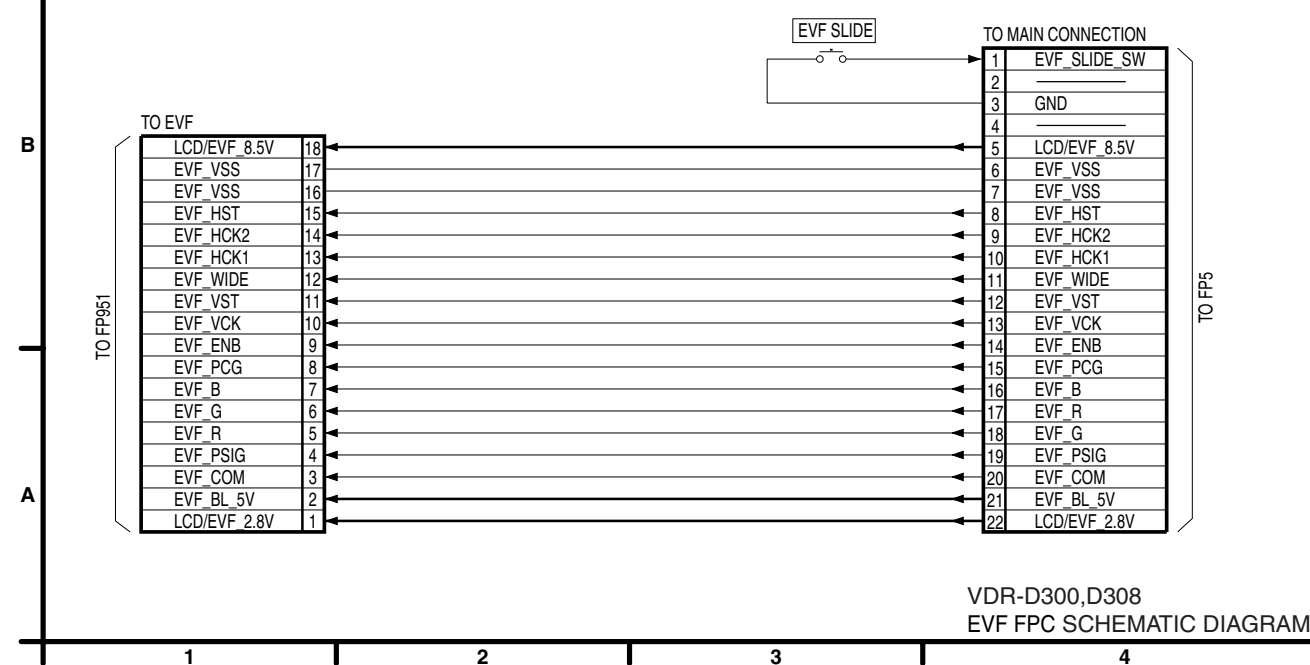



### 11.10. DVD DRIVE FPC SCHEMATIC DIAGRAM

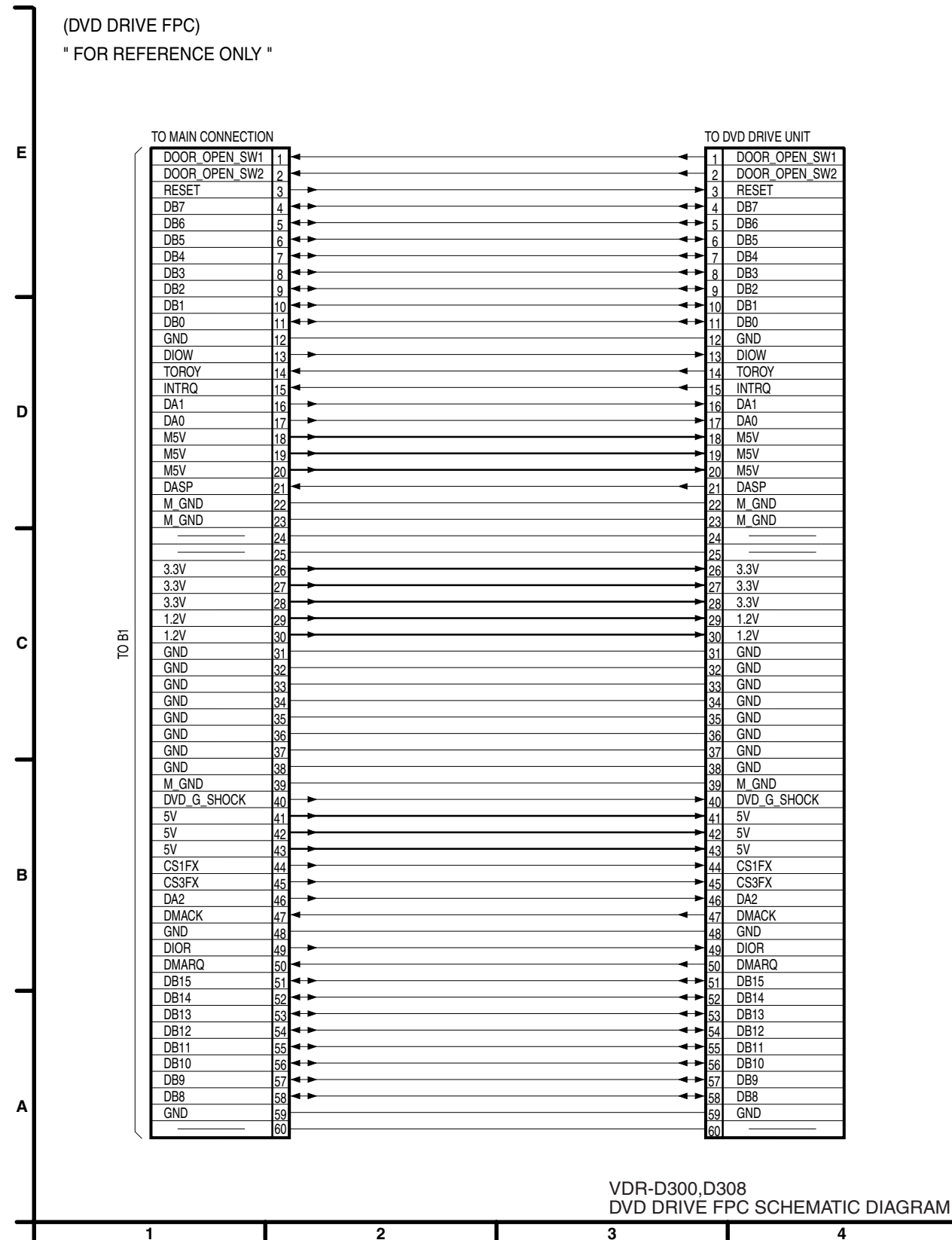

### 11.11. DISK COVER LOCK UNIT SCHEMATIC DIAGRAM

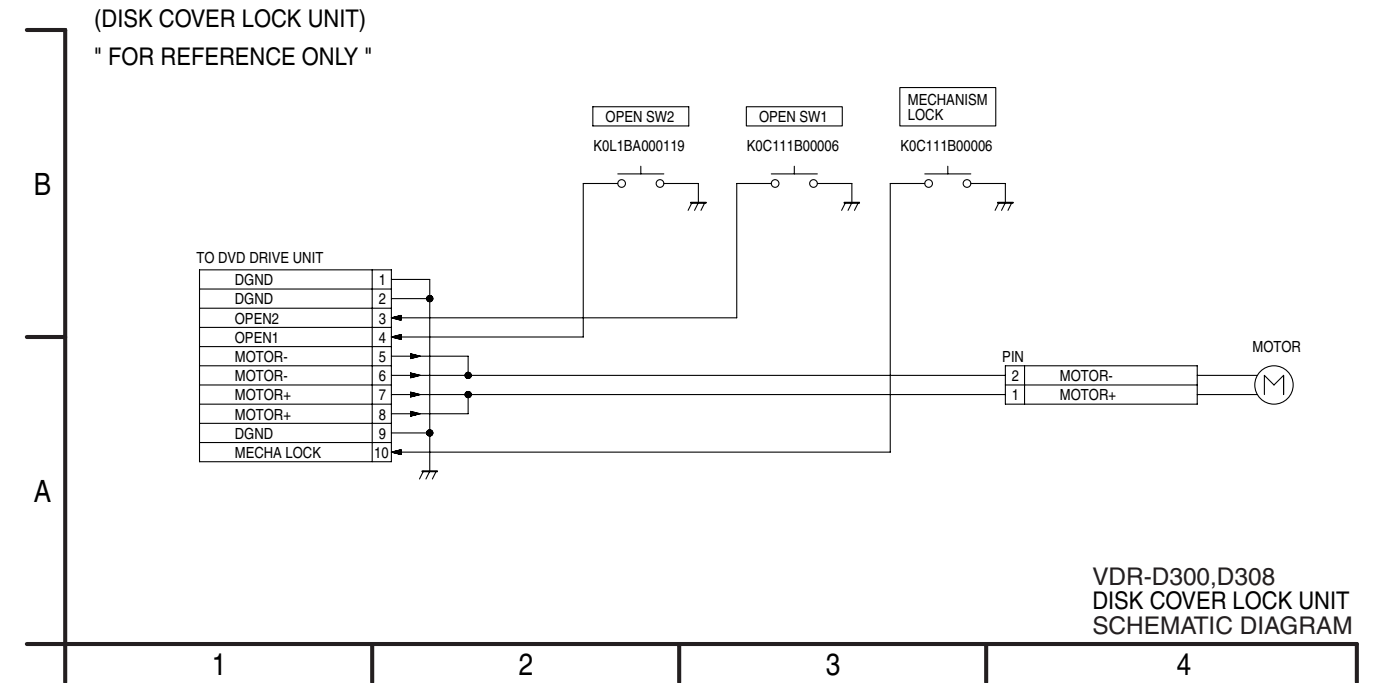

### 11.12. SIDE L UNIT SCHEMATIC DIAGRAM

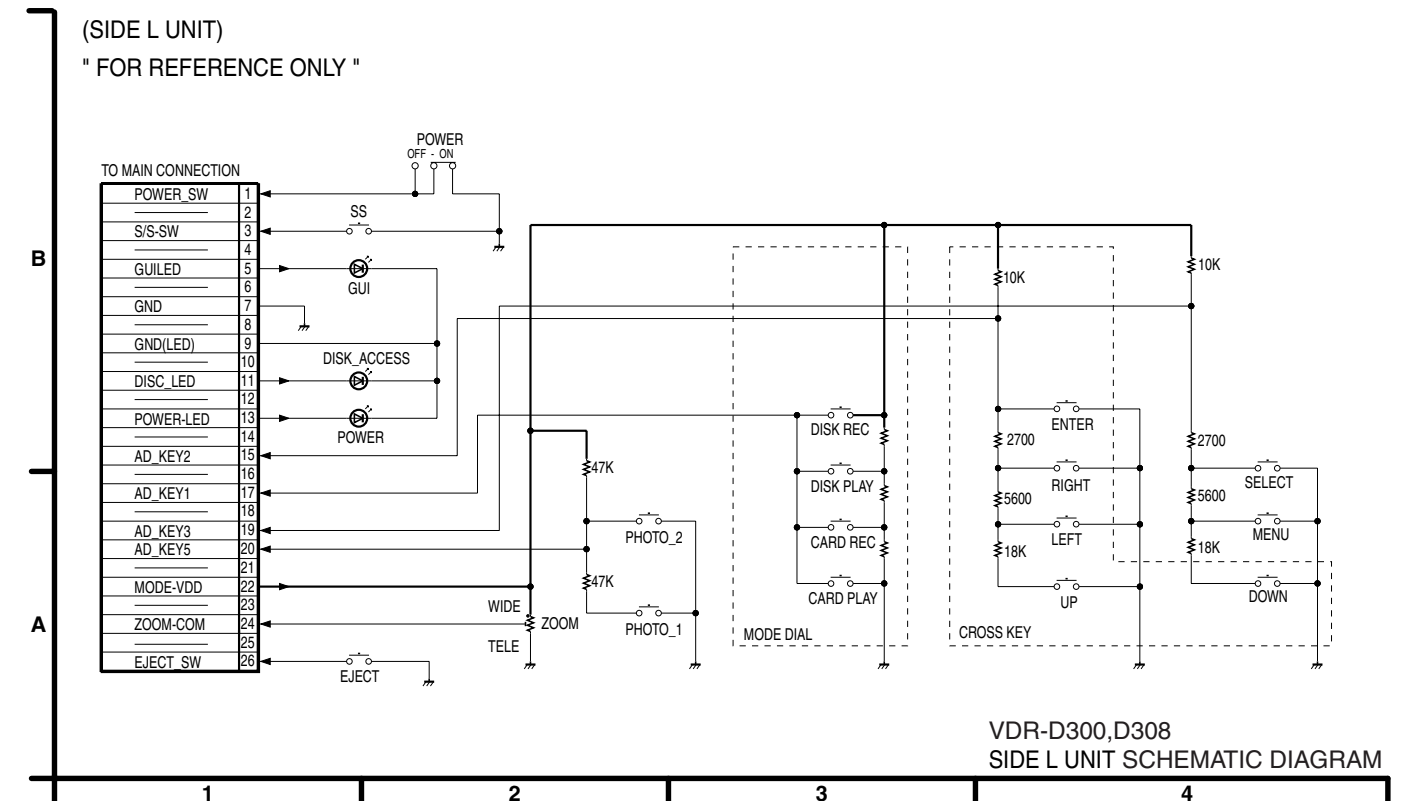

### 11.13. REAR CASE UNIT SCHEMATIC DIAGRAM

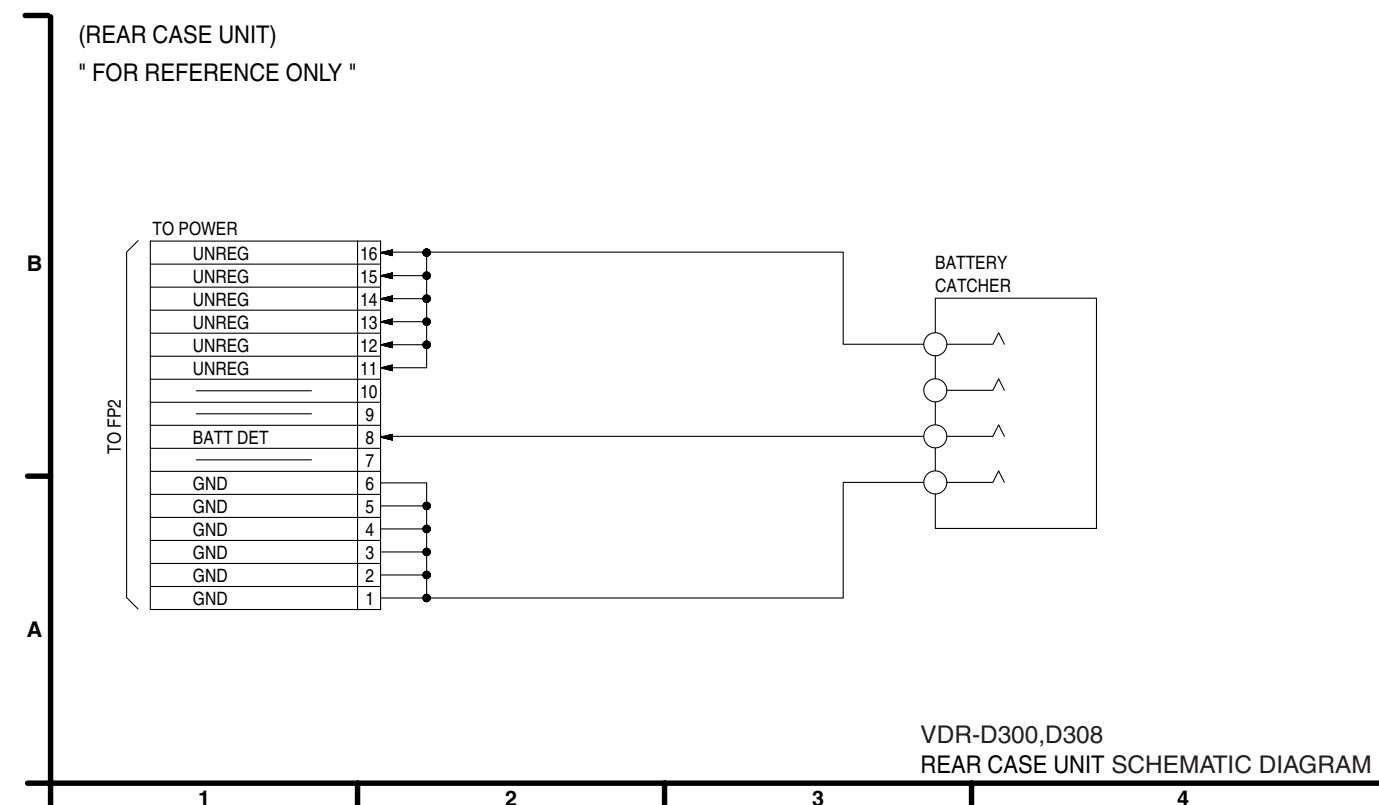

### 11.15. SIDE R FPC SCHEMATIC DIAGRAM

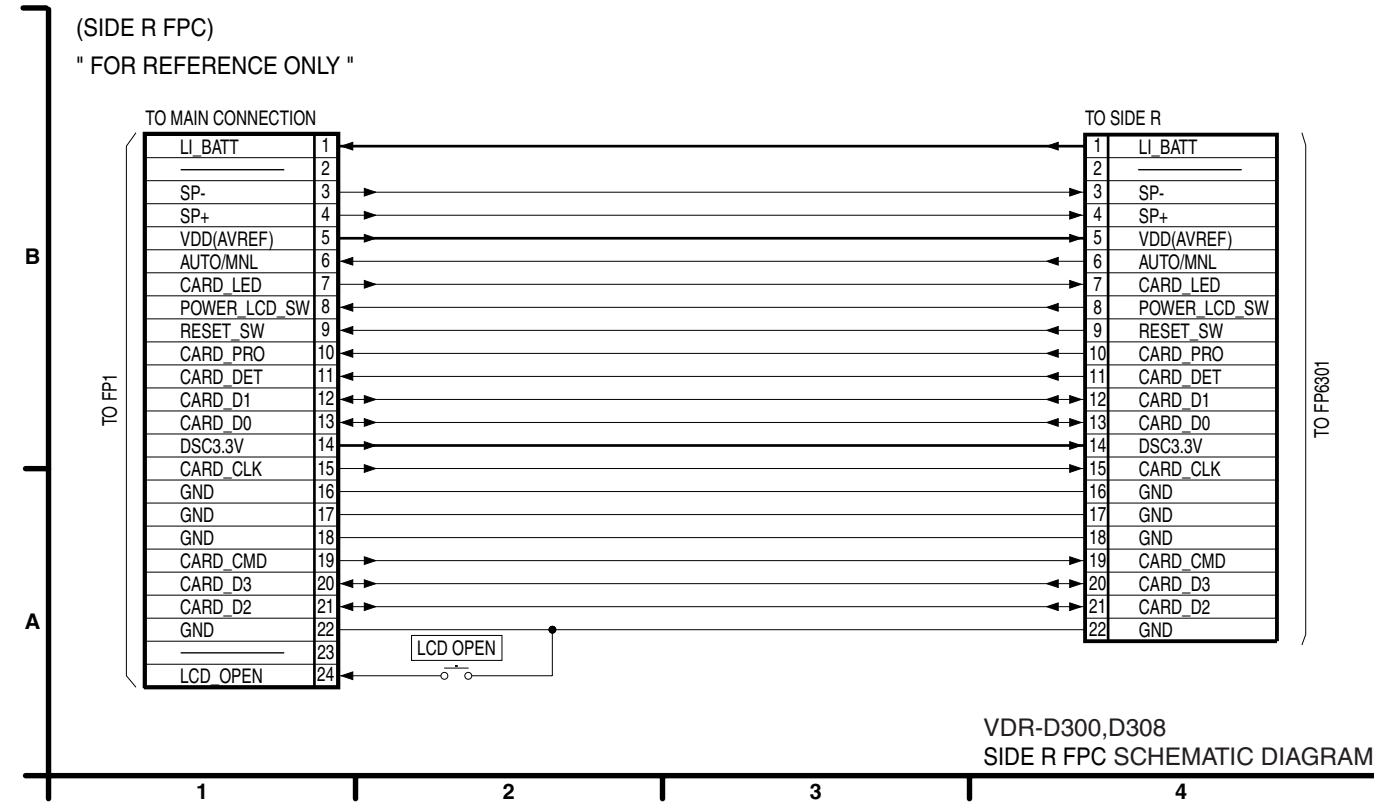

### 11.14. FRONT FPC SCHEMATIC DIAGRAM

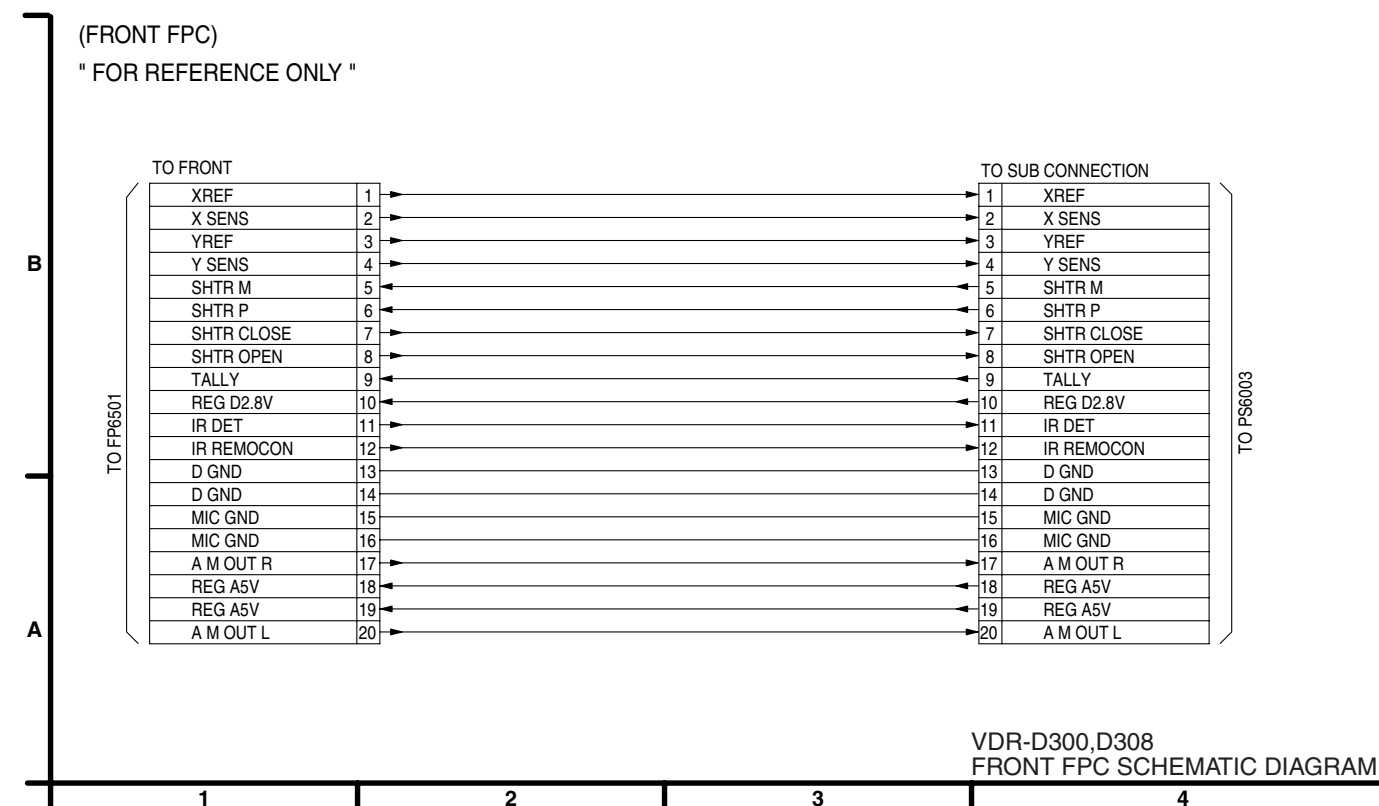

### 11.16. MONITOR FPC SCHEMATIC DIAGRAM

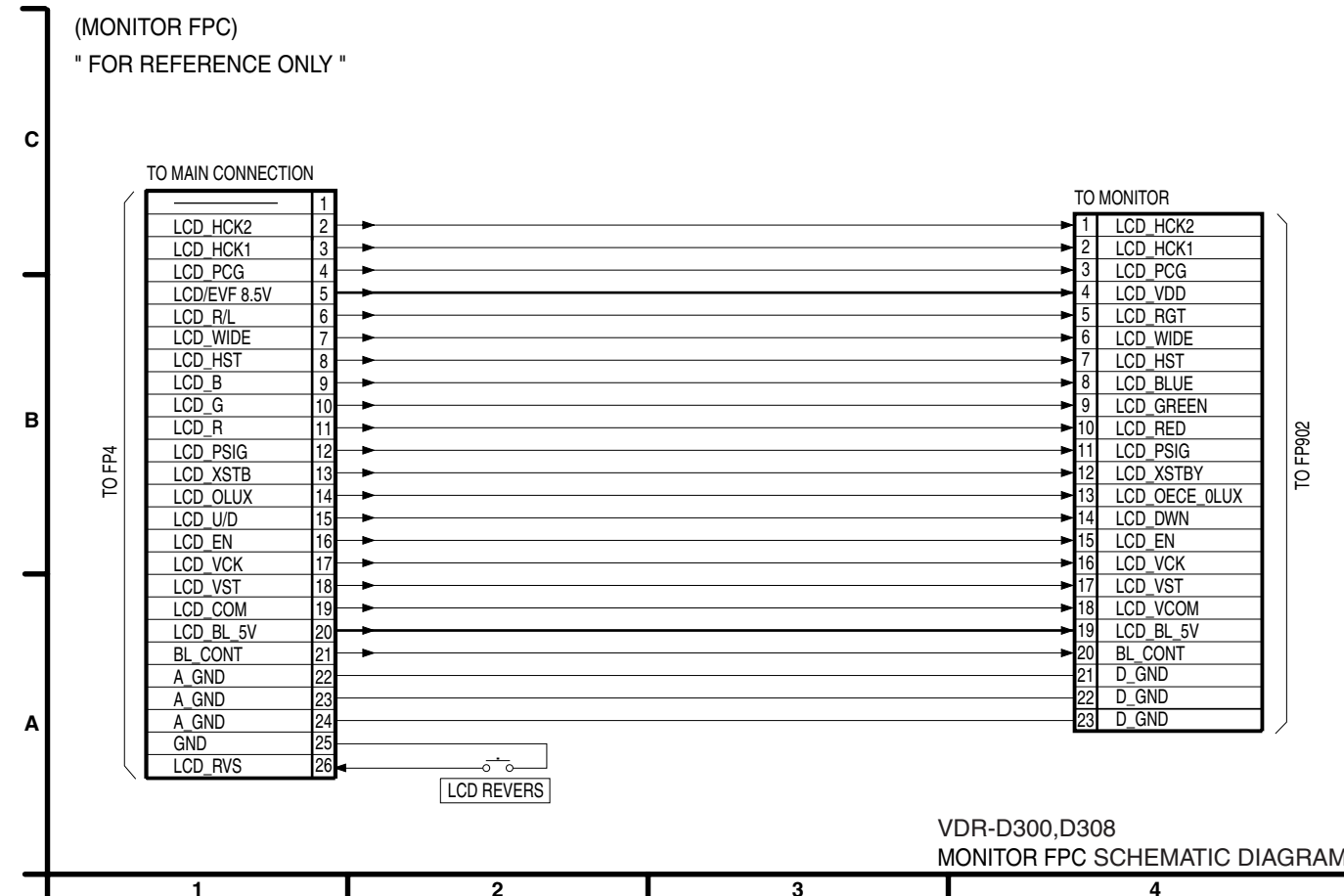

# 11.17. 3CCD FPC SCHEMATIC DIAGRAM

(3CCD FPC)  
" FOR REFERENCE ONLY "

NOTE:  
THE MEASUREMENT MODE OF THE DC  
VOLTAGE ON THIS DIAGRAM IS STOP MODE.

NOTE:  
CIRCUIT VOLTAGE AND WAVEFORM DESCRIBED HEREIN SHALL BE REGARDED  
AS REFERENCE INFORMATION WHEN PROBING DEFECT POINT BECAUSE IT MAY  
DIFFER FROM AN ACTUAL MEASURING VALUE DUE TO DIFFERENCE OF MEASURING  
INSTRUMENT AND ITS MEASURING CONDITION AND PRODUCT ITSELF.

➔ : VIDEO MAIN SIGNAL PATH

H  
G  
F  
E  
D  
C  
B  
A

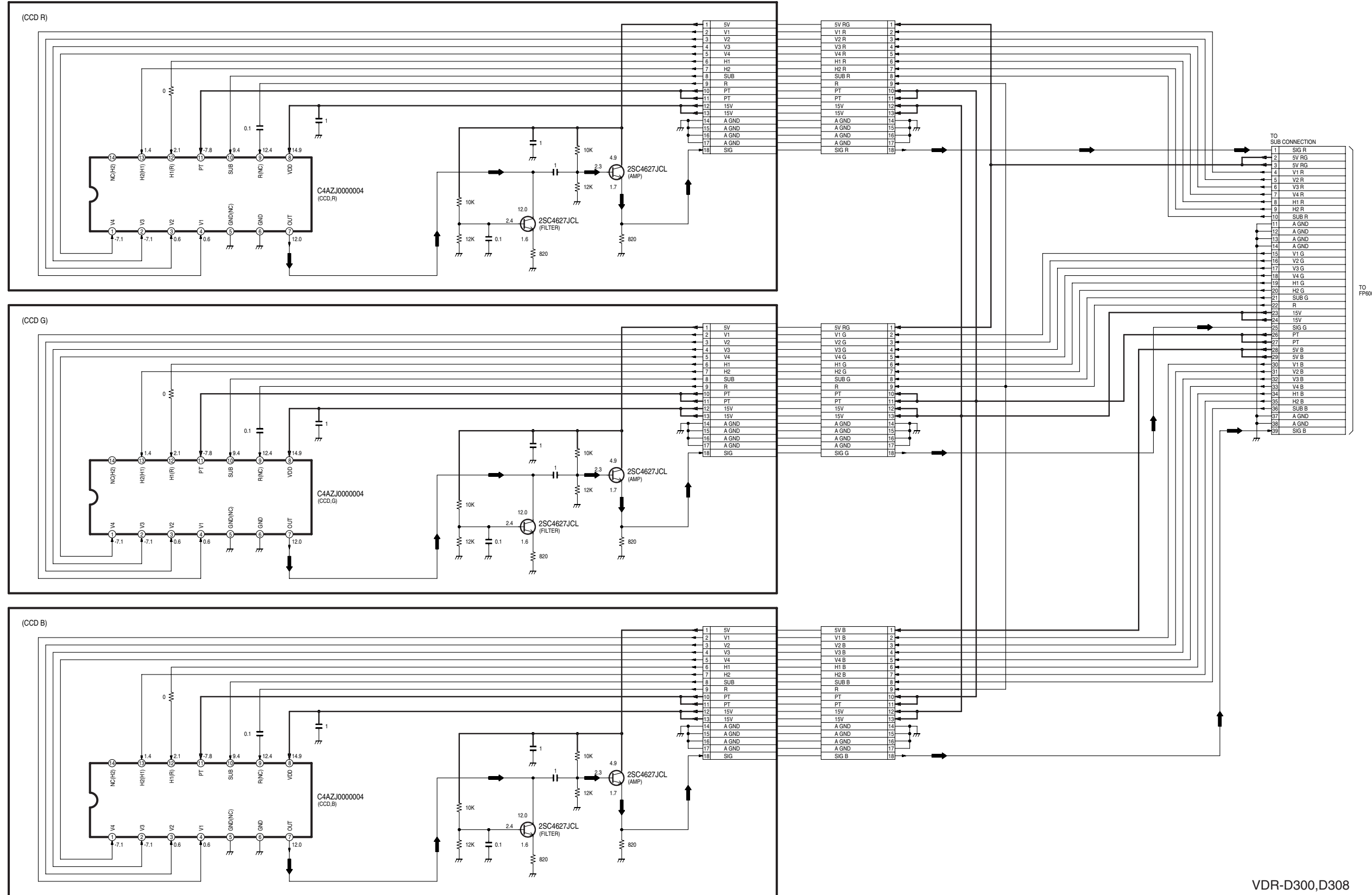

TO  
FP6002

VDR-D300,D308  
3CCD FPC SCHEMATIC DIAGRAM

1 2 3 4 5 6 7 8 9 10 11 12



# 12 Printed Circuit Board

## 12.1. FLASH P.C.B.

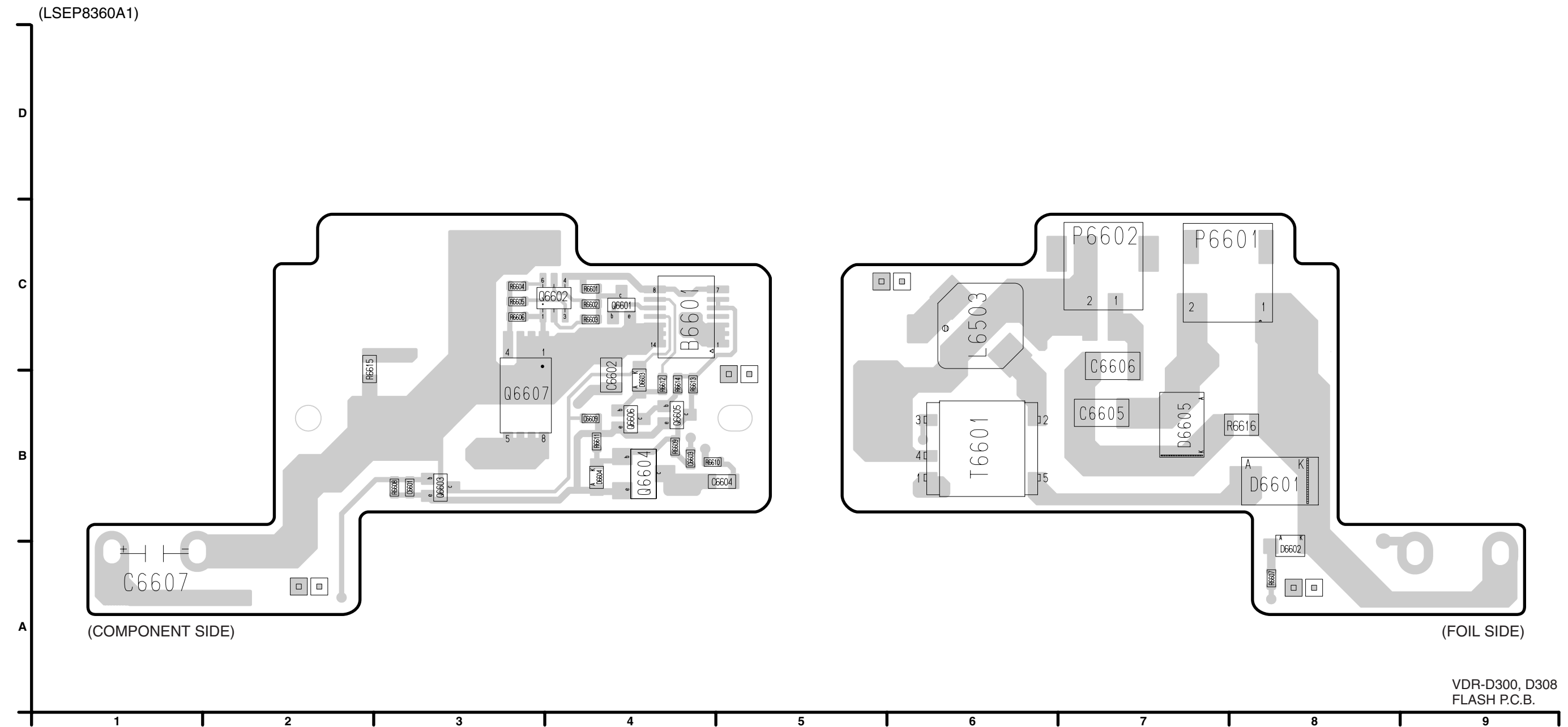

## 12.2. FRONT P.C.B.

(LSEP8344A1)

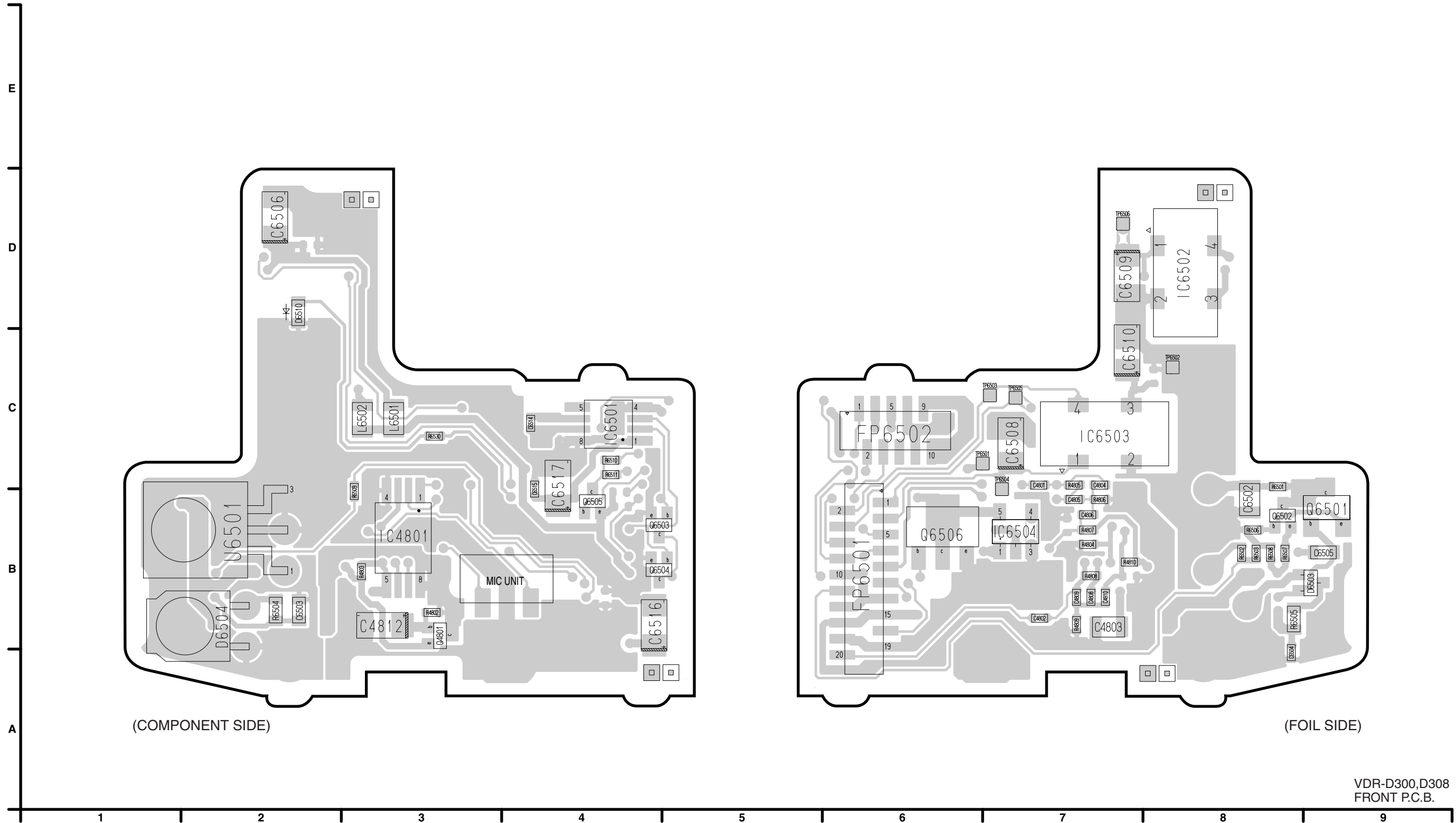

### 12.3. JACK P.C.B.

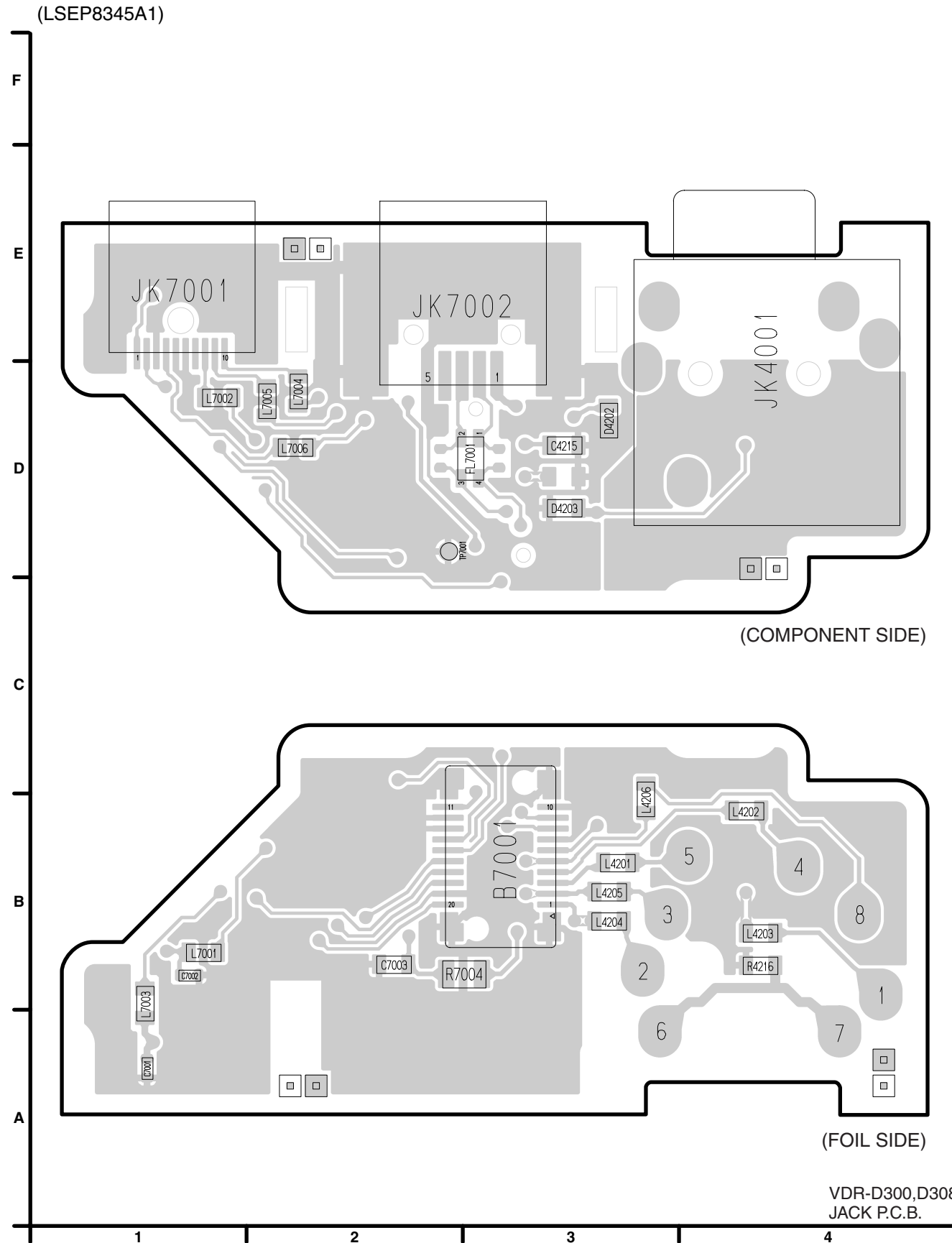

### 12.4. EVF P.C.B.

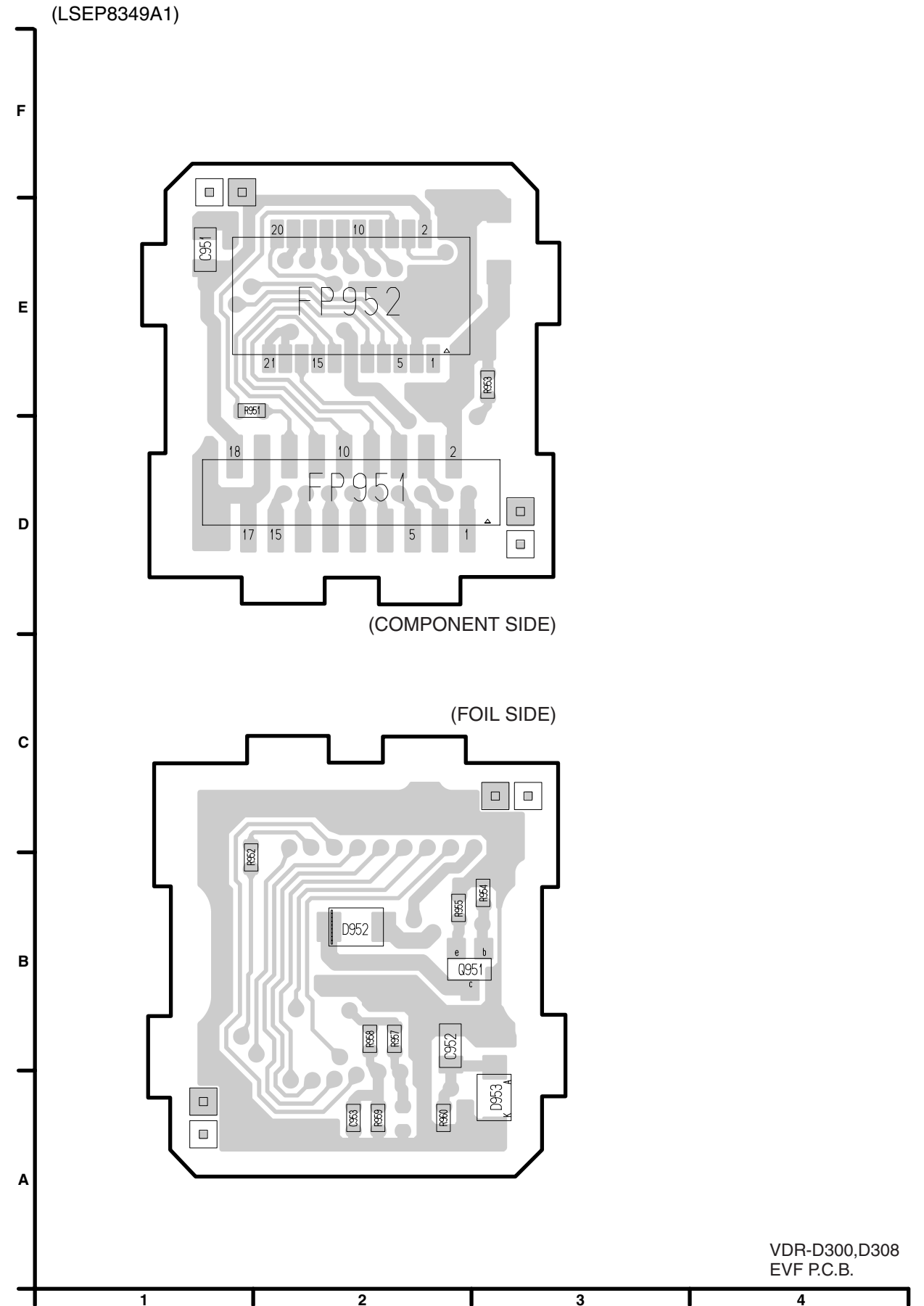

### 12.5. SIDE R P.C.B.

(LSEP8347A1)

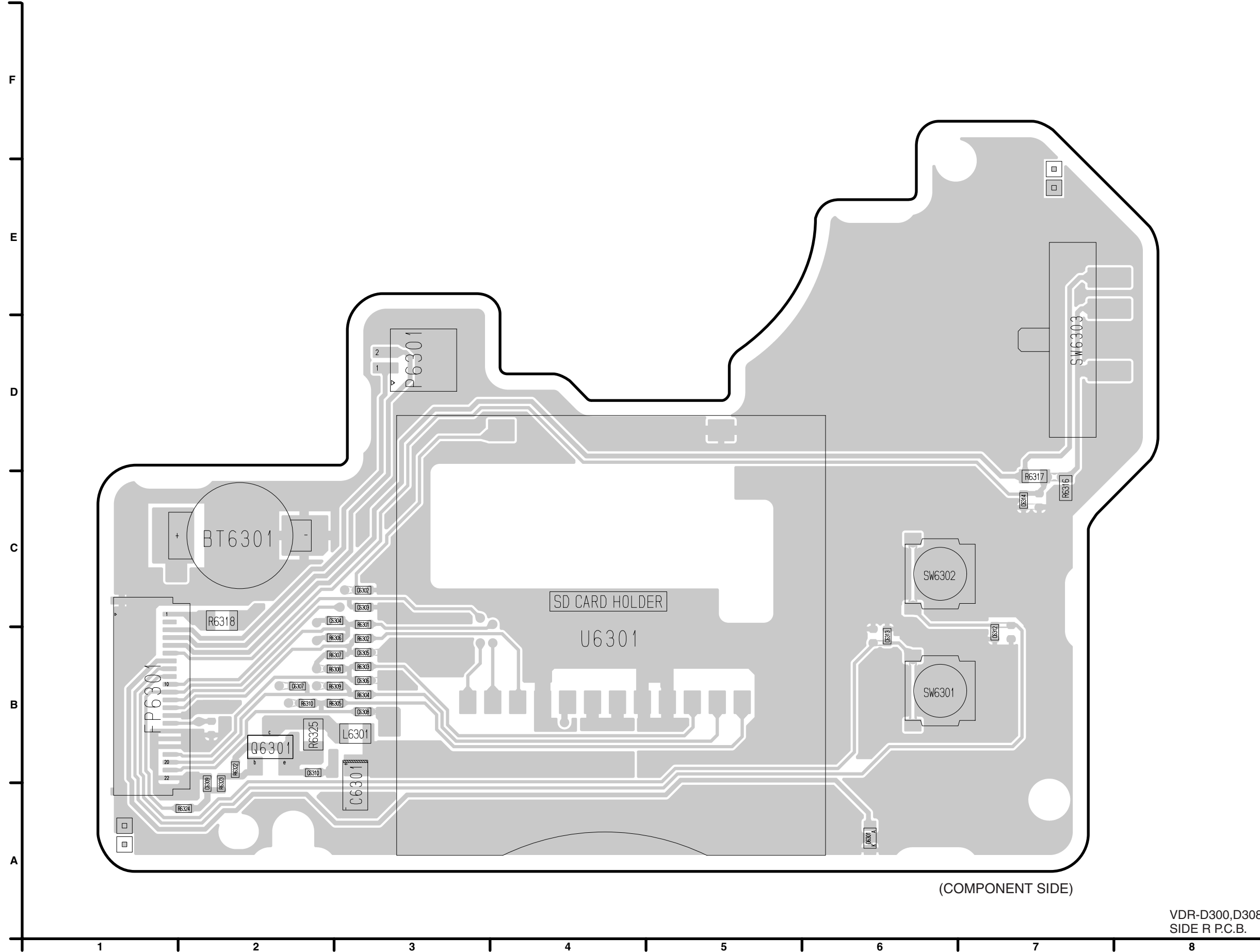

(COMPONENT SIDE)

VDR-D300,D308  
SIDE R P.C.B.



### 12.6. MONITOR P.C.B.

(LSEP8348A1)

F  
E  
D  
C  
B  
A

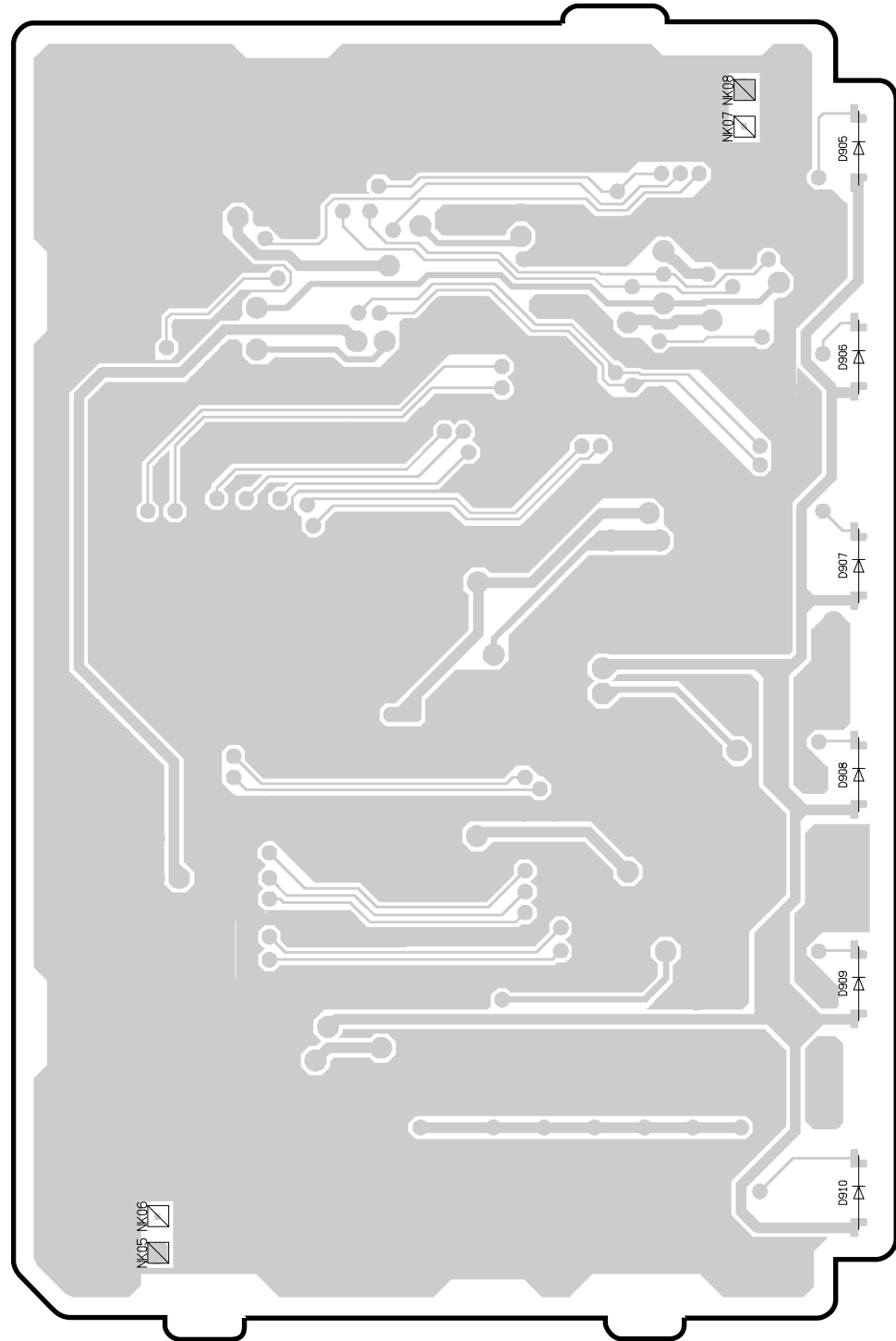

(COMPONENT SIDE)

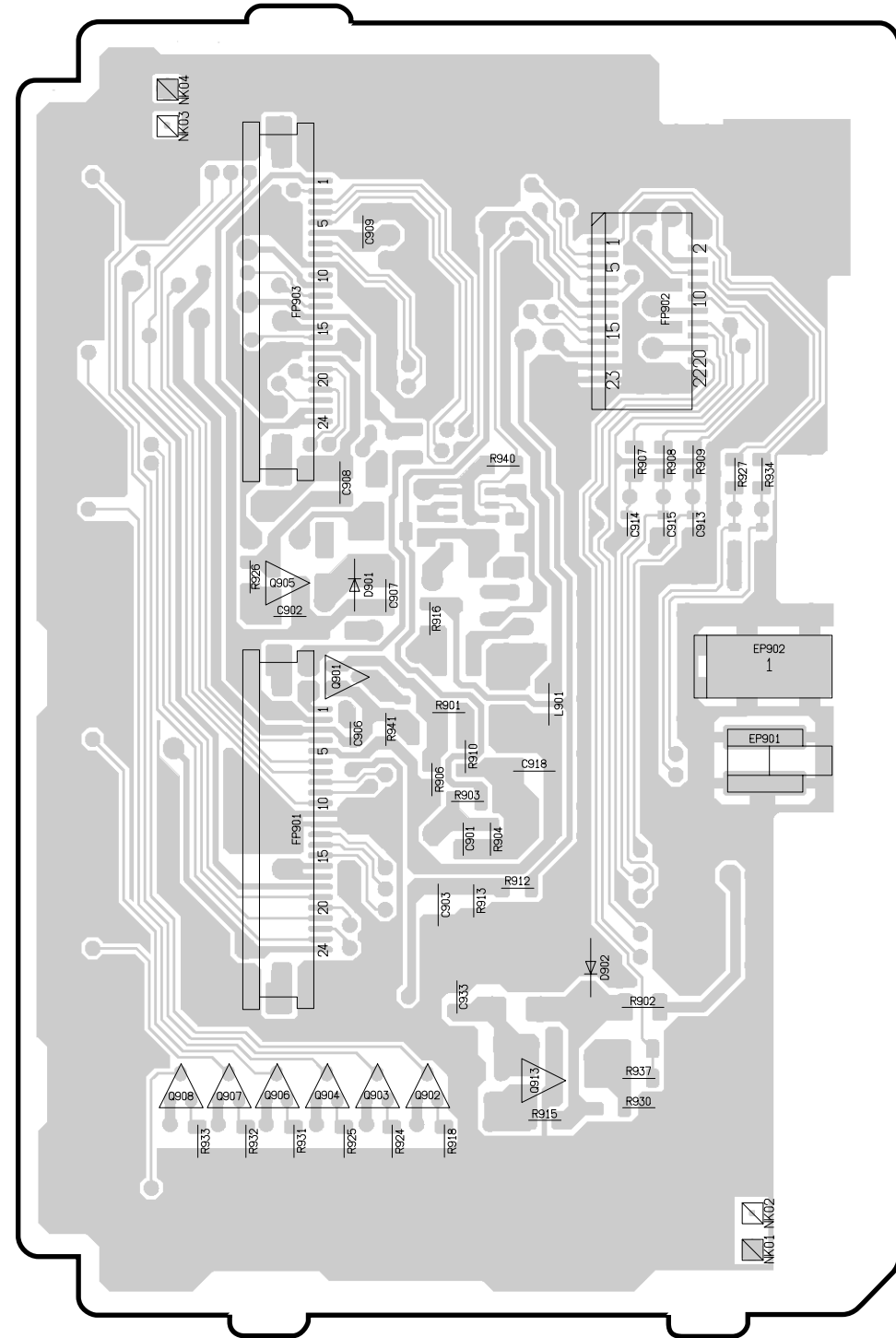

(FOIL SIDE)

1 2 3 4 5 6 7 8 9



# 13 Parts and Exploded Views

## 13.1. EXPLODED VIEWS

### 13.1.1. FRAME & CASING SECTION

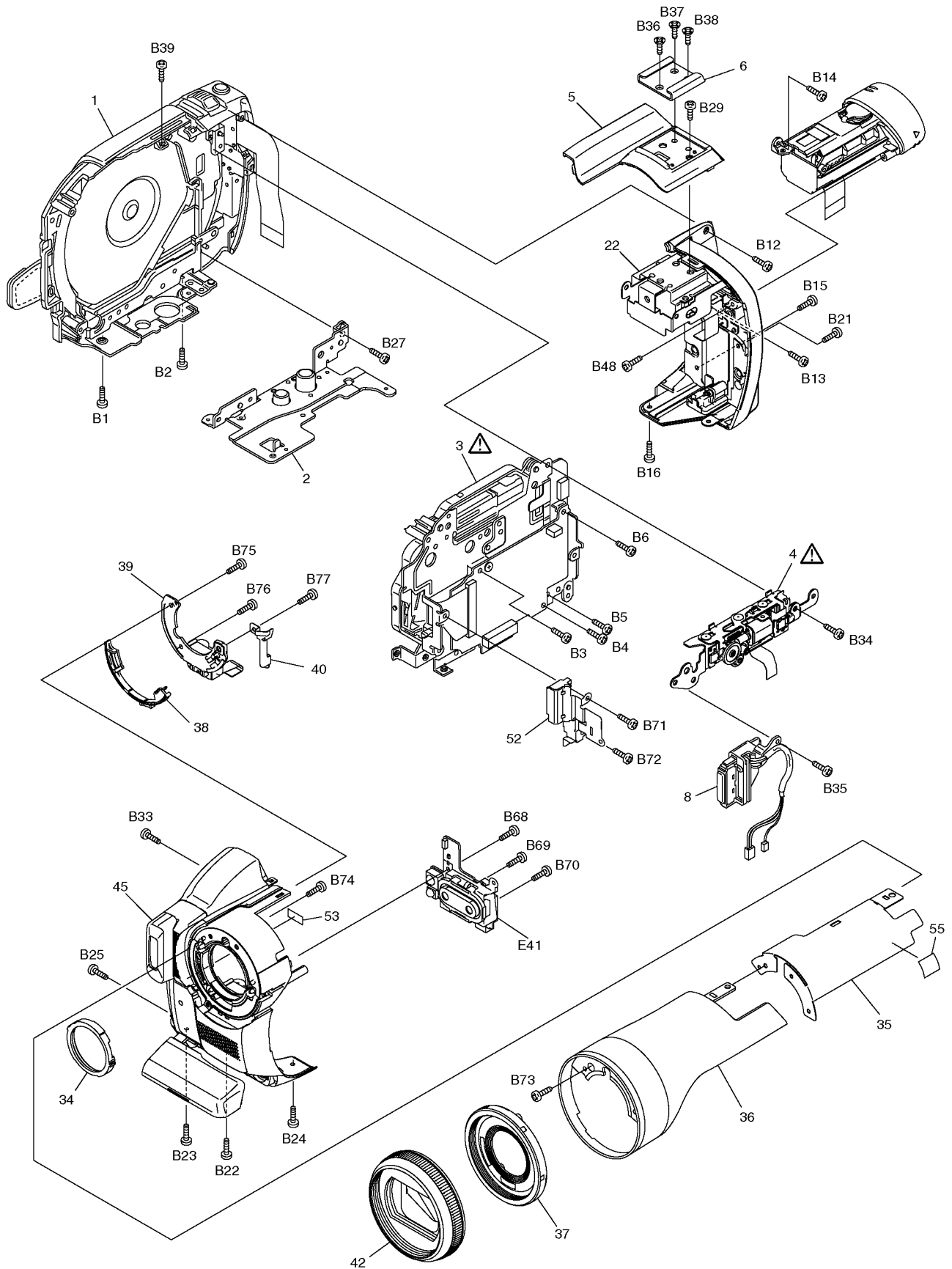



### 13.1.2. LCD SECTION

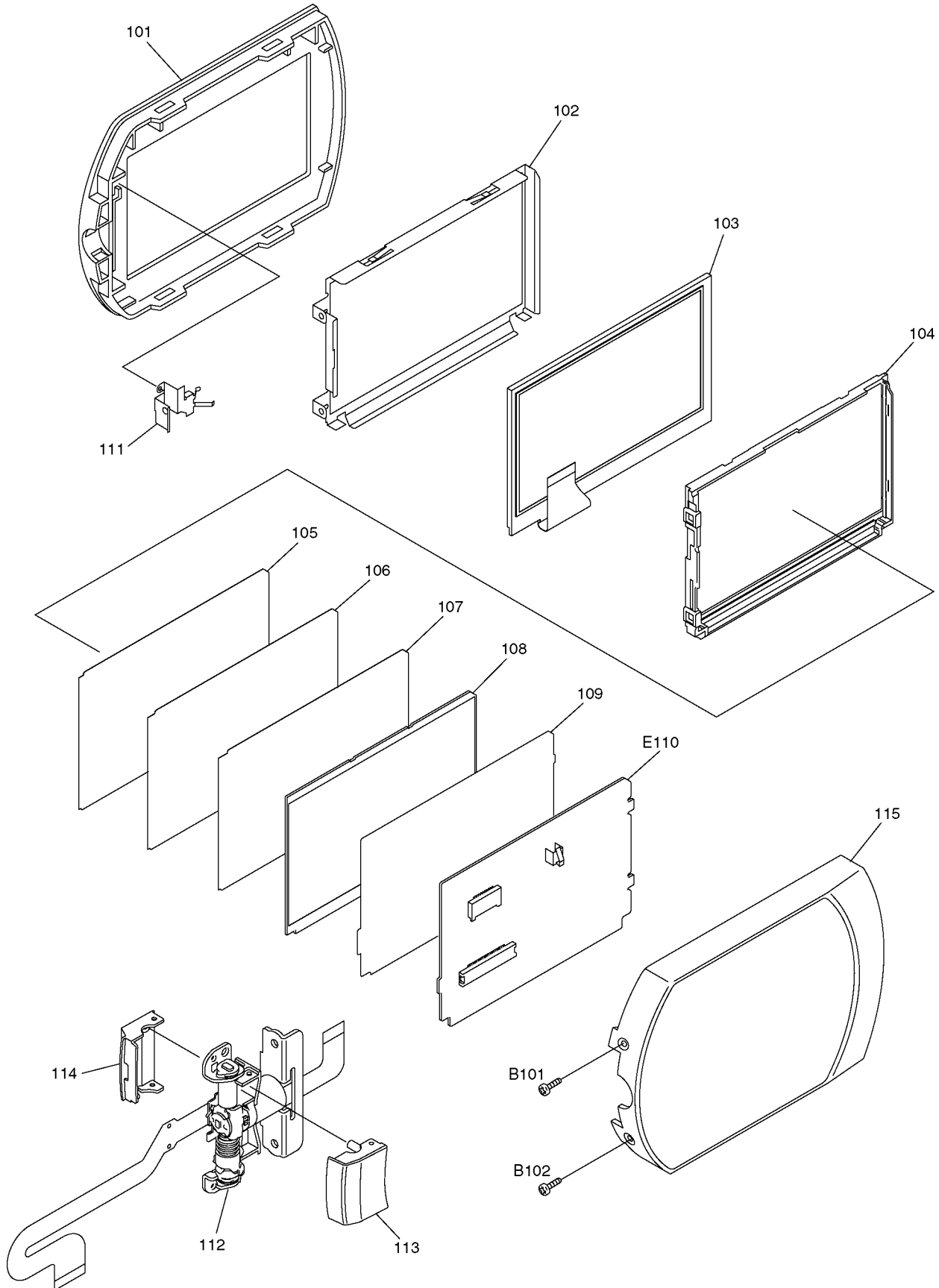

### 13.1.3. CAMERA LENS SECTION

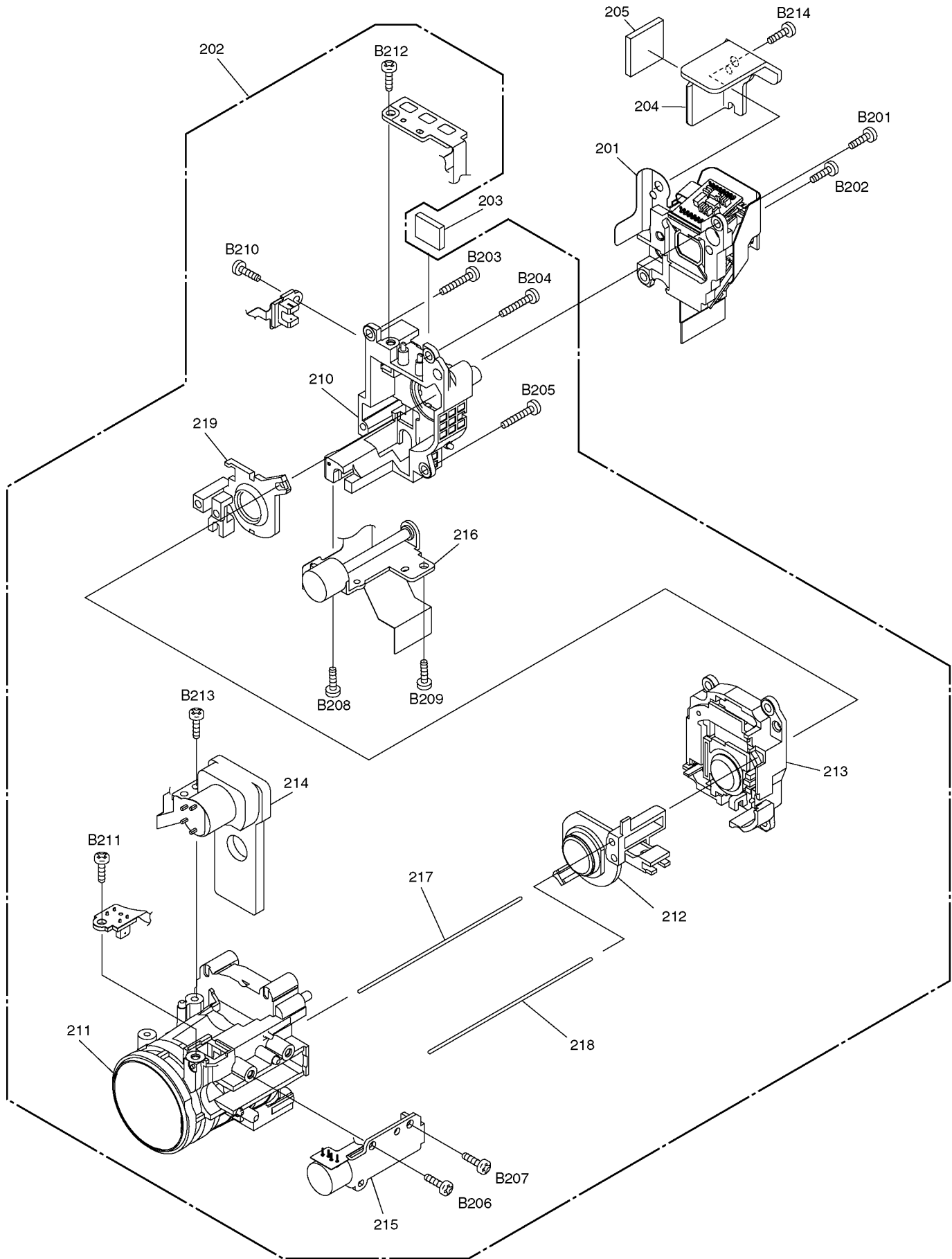

### 13.1.4. EVF SECTION

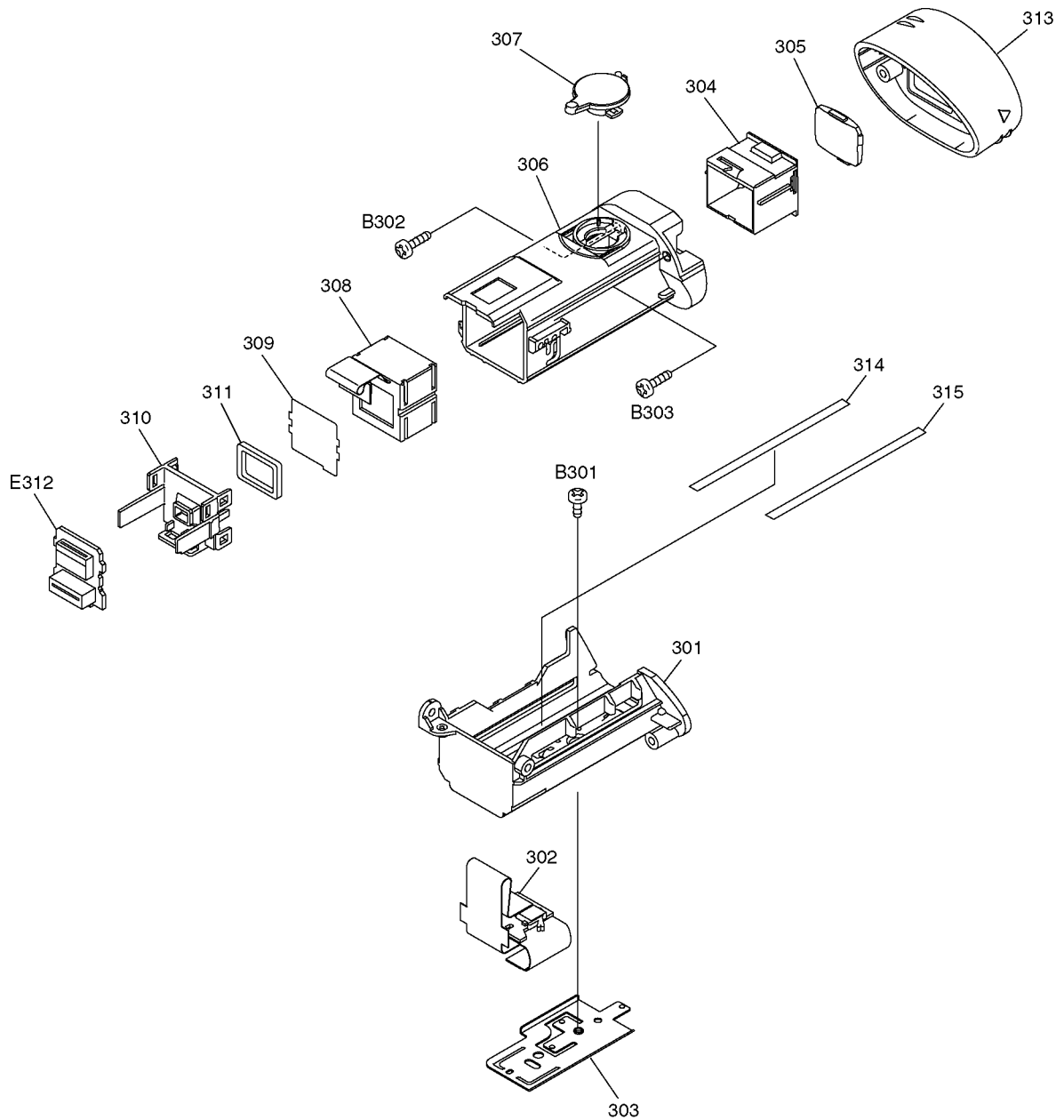

### 13.1.5. PACKING PARTS & ACCESSORIES SECTION

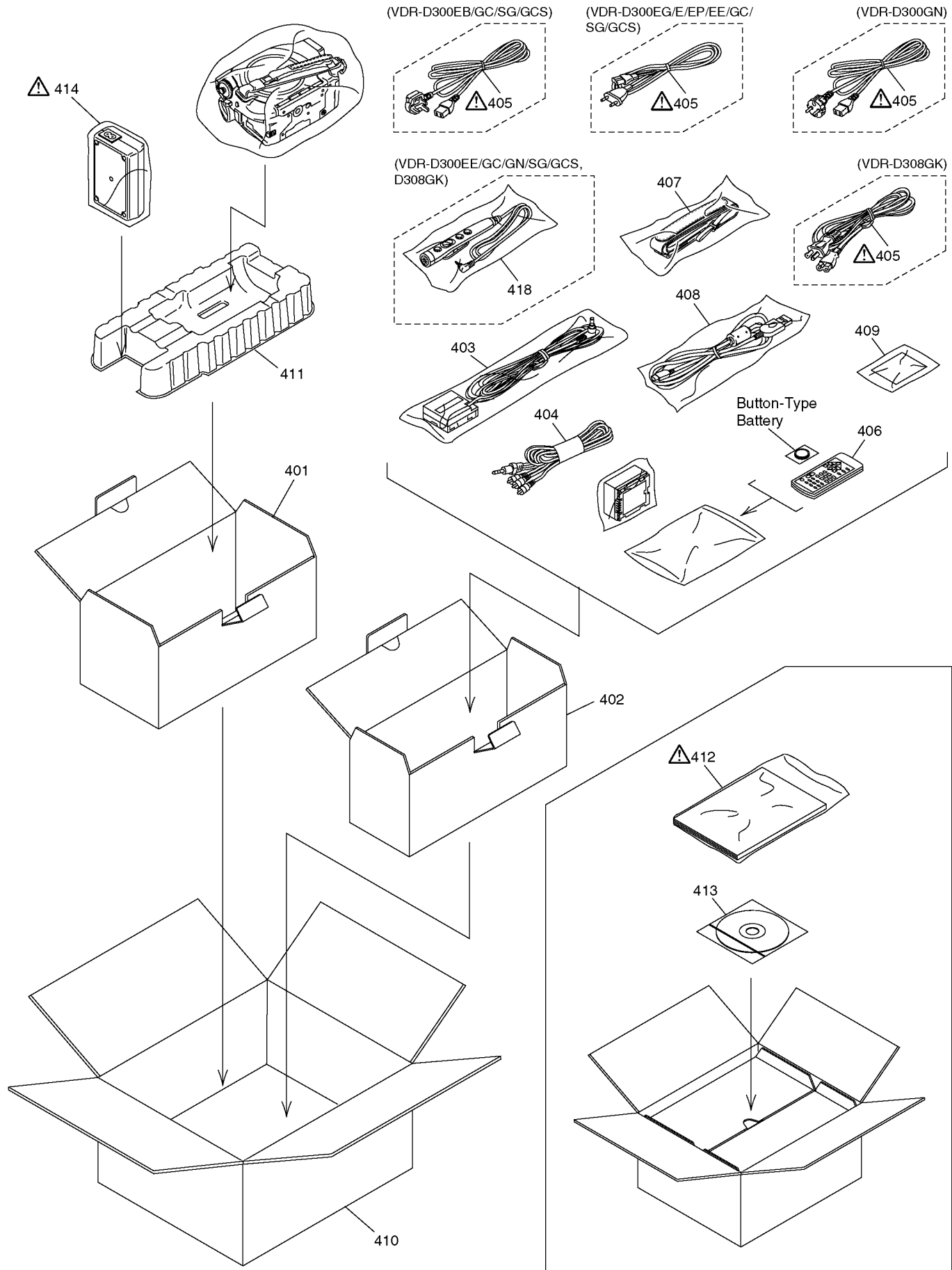



## 13.2. REPLACEMENT PARTS LIST

BEFORE REPLACING PARTS, READ THE FOLLOWING:

### 13.2.1. REPLACEMENT NOTES

#### 13.2.1.1. General Notes

1. Use only original replacement parts:  
To maintain original function and reliability of repaired units, use only original replacement parts which are listed with their part numbers in the parts list.
2. IMPORTANT SAFETY NOTICE  
Components identified by the sign have special characteristics important for safety. When replacing any of these components, use only the specified parts.
3. SPECIAL NOTE  
All integrated circuits and many other semiconductor devices are electrostatically sensitive and therefore require the special handling techniques described under the ELECTROSTATICALLY SENSITIVE (ES) DEVICES section of this service manual.
4. Parts with no Ref. No. in "EXPLODED VIEWS" are not supplied.  
And some Ref. No. will be skipped.  
Be sure to make your orders of replacement parts according to the parts list.
5. Parts different in shape or size may be used. However, only interchangeable parts will be supplied as service replacement parts.
6. Definition of Parts supplier:
  - a. Parts with mark ""SPC"" in the Remarks column are supplied from Spare Parts Center of Panasonic AVC Company.
  - b. Parts without mark in the Remarks column are supplied from PSEC.
7. Item numbers with capital letter E (Example: E10, E20,...) in the Ref. No. column are shown in the exploded views.
8. Parts whose Ref. Nos. are the same are interchangeable as replacement parts. Any of these parts may be ordered and used as a replacement part.

#### 13.2.1.2. Mechanical Replacement Notes

1. Abbreviation  
RTL: Retention Time Limited  
This indicates that the retention time is limited for this item.  
After the discontinuation of this item in production, it will no longer be available.

#### 13.2.1.3. Electrical Replacement Notes

1. Unless otherwise specified;  
All resistors are in  $\Omega$ , K = 1,000  $\Omega$ , M = 1,000 k $\Omega$ .
2. Abbreviation  
RTL: Retention Time Limited  
This indicates that the retention time is limited for this item.  
After the discontinuation of this item in production, it will no longer be available.  
NR: Non Repairable Board Ass'y  
MGF CHIP: Metal Glaze Film Chip  
C CHIP: Ceramic Chip  
COMPLX CMP: Complex Component  
W FLMPRF: Wirewound Flameproof  
P.C.B.: Circuit Board Assembly  
P.C.B.: Printed Circuit Board  
E.S.D.: Electrostatically Sensitive Devices
3. SERVICE OF CHIP PARTS  
When servicing chip parts, please use a soldering iron of less than 30 W.
4. When replacing 0  $\Omega$  resistor, a wire can be substituted for it.
5. Parts with mark "CSP" in the Remarks column are CSP (Chip Size Package) IC.

## 13.2.2. MECHANICAL REPLACEMENT PARTS LIST

### Definition of Parts supplier:

1. Parts with mark "SPC" in the Remarks column are supplied from Spare Parts Center of Panasonic AVC Company.
2. Parts without mark in the Remarks column are supplied from PSEC.

### 13.2.2.1. FRAME & CASING SECTION PARTS LIST

Ref. No.	Part No.	Part Name & Description	Remarks
1	LSYK1727	SIDE L/OPERATION UNIT	
2	LSXY0959	BOTTOM ANGLE UNIT	
3	LMXK1931AS-2	DVD DRIVE FRAME UNIT	△ VDR-D300EG/E/EB/EP/GC
3	LMXK1931AS-3	DVD DRIVE FRAME UNIT	△ VDR-D300SG/GCS
3	LMXK1931AS-4	DVD DRIVE FRAME UNIT	△ VDR-D300GN
3	LMXK1931AS-5	DVD DRIVE FRAME UNIT	△ VDR-D300EE
3	LMXK1931AS-6	DVD DRIVE FRAME UNIT	△ VDR-D308GK
4	LSXY1001	DISK COVER LOCK UNIT	△
5	LSKM1204	SHOE BASE	
6	VMP8492	SHOE PLATE	
7	LSKM1205	EVF COVER	
8	LSEQ0828	FLASH/TRIGGER UNIT	
9	LSSC0895	HEAT CONDUCT SHEET	
13	LSXY0964	HEAT SINK/ANGLE UNIT	
14	LSMD0837	SUPPORT PIECE	
16	LSMD0838	CAPACITOR HOLDER A	
17	LSMD0839	CAPACITOR HOLDER B	
18	LSEP8350A1	DRIVE FPC UNIT	
19	LSSC0844	MAIN SHIELD PLATE	
20	LSSC0891	HEAT CONDUCT SHEET	
21	LSSC0894	HEAT CONDUCT SHEET	
22	LSYK1729	REAR/SHOE ANGLE UNIT	
23	LSMX0229	BARRIER SHEET	
25	LSYK1740	SIDE CASE R UNIT	
27	LOAA02A00062	SPEAKER	
28	LSEP8355A1	SIDE R FPC	
29	LSMC0145	SPEAKER PLATE	
30	LSMD0843	SIDE R PIECE	
32	LSMA0943	SUPPORT ANGLE	
33	VMG1107	DAMPER RUBBER	
34	VMG1705	LENS RUBBER	
35	LSSC0850	TOP HEAT SINK PLATE	
36	LSKM1202	TOP COVER	
37	LSKM1203	LENS PIECE	
38	VML3925-1L	BARRIER LEVER	
39	N9ZZ00000326	BARRIER MOTOR UNIT	
40	LSSC0851	FRONT HEAT SINK PLATE	
42	LSYK1747	HOOD BARRIER UNIT	
44	LSJB8352	FRONT FPC	
45	LSYK1746	FRONT CASE UNIT	
50	LSSC0899	RF TOP EARTH PLATE	
51	LSSC0900	RF BOTTOM EARTH PLATE	
52	LSSC0903	EARTH PLATE	
53	LSSC0904	EARTH CUSHION	
55	LSMF0510	BOTH SIDE TAPE	
56	LSSC0911	HEAT CONDUCT SHEET	
B1	XQN16+BF4FN	SCREW, STEEL	
B2	XQN16+BF4FN	SCREW, STEEL	
B3	XQN16+BF4FN	SCREW, STEEL	
B4	XQN16+BF4FN	SCREW, STEEL	

Ref. No.	Part No.	Part Name & Description	Remarks
B5	XQN16+BF4FN	SCREW, STEEL	
B6	XQN16+BF4FN	SCREW, STEEL	
B7	XQN16+BF4FN	SCREW, STEEL	
B8	XQN16+BF4FN	SCREW, STEEL	
B9	XQN16+BF4FN	SCREW, STEEL	
B10	XQN16+BF4FN	SCREW, STEEL	
B11	XQN16+BF4FN	SCREW, STEEL	
B12	XQN16+BF4FN	SCREW, STEEL	
B13	XQN16+BF4FN	SCREW, STEEL	
B14	XQN16+BF4FN	SCREW, STEEL	
B15	XQN16+BF4FN	SCREW, STEEL	
B16	XQN16+BF4FN	SCREW, STEEL	
B17	XQN16+BF4FN	SCREW, STEEL	
B18	XQN16+BF4FN	SCREW, STEEL	
B19	XQN16+BF4FN	SCREW, STEEL	
B20	XQN16+BF4FN	SCREW, STEEL	
B21	XQN16+BF4FN	SCREW, STEEL	
B22	XQN16+BF4FN	SCREW, STEEL	
B23	XQN16+BF4FN	SCREW, STEEL	
B24	XQN16+BF4FN	SCREW, STEEL	
B25	XQN16+BF4FN	SCREW, STEEL	
B27	XQN16+BJ4FN	SCREW, STEEL	
B28	XQN16+BJ4FN	SCREW, STEEL	
B29	XQN16+BJ4FN	SCREW, STEEL	
B30	XQN16+BJ4FN	SCREW, STEEL	
B31	XQN16+BJ4FN	SCREW, STEEL	
B32	XQN16+BJ4FN	SCREW, STEEL	
B33	XQN16+BJ4FN	SCREW, STEEL	
B34	XQN2+BJ5FN	SCREW, STEEL	
B35	XQN2+BJ5FN	SCREW, STEEL	
B36	XQS2+A35FN	SCREW, STEEL	
B37	XQS2+A35FN	SCREW, STEEL	
B38	XQS2+A35FN	SCREW, STEEL	
B39	XQN16+B2FN	SCREW, STEEL	
B40	XQN16+BF4FN	SCREW, STEEL	
B41	XQN16+BF4FN	SCREW, STEEL	
B42	XQN16+BF4FN	SCREW, STEEL	
B43	XQN16+BJ4FN	SCREW, STEEL	
B44	XQN16+BJ4FN	SCREW, STEEL	
B45	XQN16+BF4FN	SCREW, STEEL	
B46	XQN16+BF4FN	SCREW, STEEL	
B47	XQN16+BF4FN	SCREW, STEEL	
B48	XQN16+BJ4FN	SCREW, STEEL	
B51	XQN16+BJ4FN	SCREW, STEEL	
B52	XQN16+BJ4FN	SCREW, STEEL	
B53	XQN16+BJ4FN	SCREW, STEEL	
B54	XQN16+BJ4FN	SCREW, STEEL	
B55	XQN16+BJ4FN	SCREW, STEEL	
B56	XQN2+BJ5FN	SCREW, STEEL	
B57	XQN2+BJ5FN	SCREW, STEEL	
B58	XQN16+BJ4FN	SCREW, STEEL	
B59	XQN16+BJ4FN	SCREW, STEEL	
B60	XQN16+A3FN	SCREW, STEEL	
B61	XQN16+BF4FN	SCREW, STEEL	
B62	XQN16+BF4FN	SCREW, STEEL	
B68	XQN16+BJ4FN	SCREW, STEEL	
B69	XQN16+BJ4FN	SCREW, STEEL	
B70	XQN16+BJ4FN	SCREW, STEEL	
B71	XQN16+A3FN	SCREW, STEEL	
B72	XQN16+A3FN	SCREW, STEEL	
B73	XQN16+BJ4FN	SCREW, STEEL	
B74	XQN16+BJ4FN	SCREW, STEEL	
B75	XQN16+BJ5FN	SCREW, STEEL	
B76	XQN16+BJ5FN	SCREW, STEEL	
B77	XQN16+BJ5FN	SCREW, STEEL	
B80	XQN16+BJ3FN	SCREW, STEEL	
E10	LSEP8342P1FZ	MAIN P.C.B.	VDR-D300EG/E/EB/EP RTL E.S.D.

Ref. No.	Part No.	Part Name & Description	Remarks
E10	LSEP8342Q1FZ	MAIN P.C.B.	VDR-D300EE/GC/GN/SG/GCS, 308GK RTL E.S.D.
E11	VEP23648C	SUB P.C.B.	RTL E.S.D. SPC
E12	LSEP8345A1	JACK P.C.B.	RTL
E15	LSEP8360A1	FLSH P.C.B	RTL
E26	LSEP8347A1	SIDE R P.C.B.	RTL
E41	LSEP8344A1	FRONT P.C.B.	RTL

### 13.2.2.2. LCD SECTION PARTS LIST

Ref. No.	Part No.	Part Name & Description	Remarks
101	LSKM1199	LCD CASE B	
102	LSSC0848	LCD SHIELD PLATE	
103	L5BDDYH00022	LCD PANEL	
104	VGQ8662-2L	PANEL HOLDER	
105	VGL1165	PRISM SHEET A	
106	VGL1166	PRISM SHEET B	
107	VGL1164	DIFFUSION SHEET	
108	VKW3296	LEAD LIGHT PANEL	
109	VGL1167	REFLECT SHEET	
111	LSMC0146	LCD EARTH SPRING	
112	LSXY0969	SHAFT F.P.C. UNIT	
113	LSKM1200	SHAFT CASE A	
114	LSYK1837	SHAFT CASE B UNIT	
115	LSYK1737	LCD CASE A UNIT	VDR-D300EG/E/EB/EP/EE/GC/GN/SG/GCS
115	LSYK1775	LCD CASE A UNIT	VDR-D308GK
B101	XQN16+BF4FN	SCREW, STEEL	
B102	XQN16+BF4FN	SCREW, STEEL	
E110	LSEP8348A1	MONITOR P.C.B.	RTL

### 13.2.2.3. CAMERA LENS SECTION PARTS LIST

Ref. No.	Part No.	Part Name & Description	Remarks
201	VXQ1409	PRIZM U	SPC
202	VXW0738	LENS UNIT	SPC
203	VDL1748	OPTICAL FILTER	SPC
204	VSC5761	CCD HEAT SINK PLATE	SPC
205	LSSC0892	HEAT CONDUCT SHEET	
210	VDW1213	MASTER FLANGE	SPC
211	VXQ1368	1ST LENS FRAME MOVE UNIT	SPC
212	VXP2530	2ND LENS FRAME MOVE UNIT	SPC
213	VXQ1369	OIS UNIT	SPC
214	VXP2521	IRIS UNIT	SPC
215	L6HA64NC0003	ZOOM MOTOR UNIT	SPC
216	L6HA64NC0004	FOCUS MOTOR UNIT	SPC
217	VMS7638	GUIDE POLE	SPC
218	VMS7638	GUIDE POLE	SPC
219	VXP2531	4TH LENS FRAME MOVE UNIT	SPC
B201	XQN16+CJ5FJ	SCREW	SPC
B202	XQN16+CJ5FJ	SCREW	SPC
B203	XQN16+CJ7FJ	SCREW	SPC
B204	XQN16+CJ7FJ	SCREW	SPC
B205	XQN16+CJ7FJ	SCREW	SPC
B206	XQN16+CJ5FJ	SCREW	SPC
B207	XQN16+CJ5FJ	SCREW	SPC
B208	XQN16+CJ5FJ	SCREW	SPC

Ref. No.	Part No.	Part Name & Description	Remarks
B209	XQN16+CJ5FJ	SCREW	SPC
B210	XQN16+CJ5FJ	SCREW	SPC
B211	XQN16+CJ5FJ	SCREW	SPC
B212	XQN16+CJ5FJ	SCREW	SPC
B213	XQN16+CJ5FJ	SCREW	SPC
B214	XQN16+BJ4FN	SCREW	SPC

### 13.2.2.4. EVF SECTION PARTS LIST

Ref. No.	Part No.	Part Name & Description	Remarks
301	LSMD0840	EVF SLIDE BASE	
302	LSEP8358A1	EVF FPC UNIT	
303	LSMC0144	EVF LOCK PLATE	
304	LSMD0819	EVF LENS HOLDER	
305	LSFL0176	EVF LENS	
306	LSKM1197	EVF CASE	
307	LSGT0614	EYE SIGHT LEVER	
308	L5BDDXH00024	EVF LCD PANEL	
309	LSDL0300	DIFFUSION SHEET	
310	LSMD0820	EVF REFLECT PIECE	
311	LSMT0419	PROTECT CUSHION	
313	LSKM1198	EYE CAP	
314	LSMX0228	SPACER	
315	LSMX0228	SPACER	
B301	XQN16+B15FN	SCREW, STEEL	
B302	XQN16+BJ4FN	SCREW, STEEL	
B303	XQN16+BJ4FN	SCREW, STEEL	
E312	LSEP8349A1	EVF P.C.B.	RTL

### 13.2.2.5. PACKING PARTS & ACCESSORIES SECTION PARTS LIST

Ref. No.	Part No.	Part Name & Description	Remarks
401	LSPK0022	MOVIE BOX	
402	LSPK0021	ACCESSORIES BOX	
403	K2GJ2DZ00018	DC CABLE W/PLUG	
404	K2KZ9CB00001	AV CABLE W/PLUG	
405	K2CR2DA00004	AC CORD W/PLUG	△ VDR-D300EG/E/EP/EE/GC/SG/GCS
405	RJA0053-3X	AC CORD W/PLUG	△ VDR-D300EB/GC/SG/GCS
405	K2CJ2DA00011	AC CORD W/PLUG	△ VDR-D300GN
405	K2CA2CA00020	AC CORD W/PLUG	△ VDR-D308GK
406	N2QABC000019	INFRARED REMOTE CONTROL UNIT	
407	VFC3506-1A	SHOULDER STRAP	
408	K1HA05CD0010	USB CABLE W/PLUG	
409	VFC3778	LENS CLEANER	
410	LSPG2140	PACKING CASE, PAPER	VDR-D300EG/E/EB/EP
410	LSPG2141	PACKING CASE, PAPER	VDR-D300EE/GC/GN/SG/GCS
410	LSPG2143	PACKING CASE, PAPER	VDR-D308GK
411	LSPN0682	CUSHION	
412	LSQT1015-A	INSTRUCTION BOOK (GERMAN/FRENCH)	VDR-D300EG
412	LSQT1016-A	INSTRUCTION BOOK (ITALIAN/DUTCH)	VDR-D300EG
412	LSQT1017-A	INSTRUCTION BOOK (PORTUGUESE/SPANISH)	VDR-D300E

Ref. No.	Part No.	Part Name & Description	Remarks
412	LSQT1018-A	INSTRUCTION BOOK (SWEDISH/DANISH)	VDR-D300E
412	LSQT1019-A	INSTRUCTION BOOK (ENGLISH/POLISH)	VDR-D300EP
412	LSQT1020-A	INSTRUCTION BOOK (CZECH/HUNGARY)	VDR-D300EP
412	LSQT1021-A	INSTRUCTION BOOK (ENGLISH)	VDR-D300EB
412	LSQT1022-A	INSTRUCTION BOOK (ENGLISH/TAIWAN)	VDR-D300GC/SG/GCS
412	LSQT1023-A	INSTRUCTION BOOK (ARABIC/PERSIAN)	VDR-D300GC/SG/GCS
412	LSQT1024-A	INSTRUCTION BOOK (RUSSIAN/UKRAINIAN)	VDR-D300EE
412	LSQT1025-A	INSTRUCTION BOOK (ENGLISH)	VDR-D300GN
412	LSQT1026-A	INSTRUCTION BOOK (CHINESE)	VDR-D308GK
413	LSFT0650	CD-ROM	
414	DE-974GB	AC ADAPTOR UNIT	△ VDR-D300EG/E/EB/EP/EE/GC/GN/SG/GCS
414	DE-974HA	AC ADAPTOR UNIT	△ VDR-D308GK
418	N2QCAD000007	UNIVERSAL REMOTE CONTROLLER	VDR-D300EE/GC/GN/SG/GCS, 308GK

### 13.2.2.6. SERVICE FIXTURES & TOOLS PARTS LIST

Ref. No.	Part No.	Part Name & Description	Remarks
	LSVQ0028	PLIER FOR NON ZIF CONNECTOR	
	LSUQ0050	GREASE	
	LSUA0020	EXTENSION CABLE 20P	
	LSUA0059	EXTENSION CABLE 60P	
	VFK1461	EXTENSION CABLE 20P	SPC
	VFK1440	EXTENSION CABLE 10P	SPC
	VFK1492	EXTENSION CABLE 26P	SPC
	VFK1284	EXTENSION CABLE 24P	SPC
	VFK1286	EXTENSION CABLE 16P	SPC
	VFK1492	EXTENSION CABLE 26P	SPC
	VFK1282	EXTENSION CABLE 22P	SPC
	VFK1992	EXTENSION CABLE 150P	SPC
	VFK1950	EXTENSION CABLE 33P	SPC
	VFK1575C3320	EXTENSION CABLE 33P	SPC
	VFK1459	EXTENSION CABLE 39P	SPC
	VFK1164LBX1	LIGHT BOX	SPC
	VFK1164TCM02	INFINITY LENS (WITH FOCUS CHART)	SPC
	VFK1164TAR58	ATTACHMENT RING (58mm)	SPC
	VFK1164TAR55	ATTACHMENT RING (55mm)	SPC
	VFK1164TAR52	ATTACHMENT RING (52mm)	SPC
	VFK1164TAR49	ATTACHMENT RING (49mm)	SPC
	VFK1164TAR46	ATTACHMENT RING (46mm)	SPC
	VFK1164TAR43	ATTACHMENT RING (43mm)	SPC
	VFK1164TAR37	ATTACHMENT RING (37mm)	SPC
	VFK1164TAR3A	ATTACHMENT RING (30.5mm)	SPC
	VFK1164TAR27	ATTACHMENT RING (27mm)	SPC
	VFK1164TFCT2	COLOR CONVERSION FILTER (C14)	SPC
	VFK1164TFWC2	WHITE CHART	SPC
	VFK1164TFCB2	COLOR BAR CHART	SPC
	VFK1164TFGS2	GRAY SCALE CHART	SPC

### 13.2.3. ELECTRICAL REPLACEMENT PARTS LIST

**Definition of Parts supplier:**

1. Parts with mark "SPC" in the Remarks column are supplied from Spare Parts Center of Panasonic AVC Company.
2. Parts without mark in the Remarks column are supplied from PSEC.

**PRINTED CIRCUIT BOARD ASSEMBLY**

Ref. No.	Part No.	Part Name & Description	Remarks
E10	LSEP8342P1FZ	MAIN P.C.B.	VDR-D300EG/E/EB/EP RTL E.S.D.
E10	LSEP8342Q1FZ	MAIN P.C.B.	VDR-D300EE/GC/GN/S G/GCS, 3 08GK RTL E.S.D.
E11	VEP23648C	SUB P.C.B.	RTL E.S.D. SPC
E12	LSEP8345A1	JACK P.C.B.	RTL
E15	LSEP8360A1	FLSH P.C.B.	RTL
E26	LSEP8347A1	SIDE R P.C.B.	RTL
E41	LSEP8344A1	FRONT P.C.B.	RTL
E110	LSEP8348A1	MONITOR P.C.B.	RTL
E312	LSEP8349A1	EVF P.C.B.	RTL

#### 13.2.3.1. JACK P.C.B.

**DIODES**

Ref. No.	Part No.	Part Name & Description	Remarks
D4202	D4ED1120A005	SURGE ABSORBER	
D4203	D4ED1120A005	SURGE ABSORBER	

**RESISTORS**

Ref. No.	Part No.	Part Name & Description	Remarks
R4216	ERJ3GEY0R00V	MGF CHIP 1/16W 0	
R7004	ERJ6GEYJ102V	MGF CHIP 1/10W 1K	

**CAPACITORS**

Ref. No.	Part No.	Part Name & Description	Remarks
C4215	F1H1A105A036	C CHIP 10V 1UF	
C7001	ECJ0EB1H332K	C CHIP 50V 3300PF	
C7002	ECJ0EB1H332K	C CHIP 50V 3300PF	
C7003	F1H1A105A036	C CHIP 10V 1UF	

**FILTERS**

Ref. No.	Part No.	Part Name & Description	Remarks
FL7001	JOMAB0000212	FILTER FILTER	

**COILS**

Ref. No.	Part No.	Part Name & Description	Remarks
L4201	J0JBC0000036	FERRITE CORE	
L4202	J0JBC0000036	FERRITE CORE	
L4203	J0JBC0000036	FERRITE CORE	
L4204	J0JBC0000036	FERRITE CORE	
L4205	J0JBC0000036	FERRITE CORE	
L4206	J0JBC0000036	FERRITE CORE	
L7001	J0JBC0000027	FERRITE BEAD CHIP	
L7002	J0JBC0000027	FERRITE BEAD CHIP	
L7003	J0JBC0000027	FERRITE BEAD CHIP	
L7004	J0JBC0000027	FERRITE BEAD CHIP	
L7005	J0JBC0000027	FERRITE BEAD CHIP	
L7006	J0JBC0000027	FERRITE BEAD CHIP	

**PIN HEADERS**

Ref. No.	Part No.	Part Name & Description	Remarks
B7001	K1KB20AA0094	CONNECTOR 20P	

**JACKS**

Ref. No.	Part No.	Part Name & Description	Remarks
JK4001	K2HC107B0003	A/V JACK SOCKET	
JK7001	K2HZ110E0002	AUDIO/VIDEO/S-VIDEO JACK SOCKET	
JK7002	K2HZ105E0007	USB MINI JACK SOCKET	

#### 13.2.3.2. FLASH P.C.B.

**TRANSISTORS**

Ref. No.	Part No.	Part Name & Description	Remarks
Q6601	UNR9214J08	TRANSISTOR SI NPN CHIP	
Q6602	XP0460100L	TRANSISTOR COMPLX CMP SI NPN CHIP	
or Q6602	B1HFCFA00003	TRANSISTOR SI NPN CHIP	
Q6603	2SD2216J08	TRANSISTOR SI NPN CHIP	
or Q6603	B1ABCF000104	TRANSISTOR SI NPN CHIP	
Q6604	B1ABPF000009	TRANSISTOR SI NPN CHIP	
Q6605	2SD2216J08	TRANSISTOR SI NPN CHIP	
or Q6605	B1ABCF000104	TRANSISTOR SI NPN CHIP	
Q6606	UNR9214J08	TRANSISTOR SI NPN CHIP	
Q6607	BIJBLP000011	TRANSISTOR COMPLX CMP SI FET CHIP	

**DIODES**

Ref. No.	Part No.	Part Name & Description	Remarks
D6601	B0ECKT000002	DIODE SI CHIP	
D6602	B0BC29000001	DIODE ZENER CHIP 290V	
D6603	MA2S728008	DIODE SI CHIP	
or D6603	B0JCDD000002	DIODE SI CHIP	
or D6603	MA2S72800L	DIODE SI CHIP	
D6604	MA2S111008	DIODE SI CHIP	
or D6604	B0ACCK000003	DIODE SI CHIP	
or D6604	MA2S11100L	DIODE SI CHIP	
D6605	B0ECKP000024	DIODE SI CHIP	

**RESISTORS**

Ref. No.	Part No.	Part Name & Description	Remarks
R6601	DOGA222JA015	MGF CHIP 1/16W 2.2K	
R6602	DOGA822JA015	MGF CHIP 1/16W 8.2K	
R6603	DOGA223JA015	MGF CHIP 1/16W 22K	
R6604	ERJ2GEJ101X	MGF CHIP 1/16W 100	
R6605	ERJ2GEJ560X	MGF CHIP 1/16W 56	
R6606	ERJ2GEJ104X	MGF CHIP 1/16W 100K	
R6607	ERJ2GEJ334X	MGF CHIP 1/16W 330K	
R6608	ERJ2GEJ564X	MGF CHIP 1/16W 560K	
R6609	ERJ2GEJ620X	MGF CHIP 1/16W 62	
R6610	ERJ2GEJ510X	MGF CHIP 1/16W 51	
R6611	DOGA103JA015	MGF CHIP 1/16W 10K	
R6612	DOGA102JA015	MGF CHIP 1/16W 1K	
R6613	DOGA103JA015	MGF CHIP 1/16W 10K	
R6614	DOGA103JA015	MGF CHIP 1/16W 10K	
R6615	ERJ3GEYJ104V	MGF CHIP 1/16W 100K	
R6616	ERJ6GEYJ105V	MGF CHIP 1/10W 1M	

**CAPACITORS**

Ref. No.	Part No.	Part Name & Description	Remarks
C6601	FIG1A1040006	C CHIP 10V 0.1UF	
C6602	ECJ1VB1C105K	C CHIP 16V 1UF	
C6603	FIG1E472A062	C CHIP 25V 4700PF	
C6604	ECJ1VB1H471K	C CHIP 50V 470PF	
C6605	FLK2E223A004	C CHIP 250V 0.022UF	

Ref. No.	Part No.	Part Name & Description	Remarks
C6606	FLK2E4730002	C CHIP 250V 0.047UF	
C6607	F2AZZ6500005	ELECTROLYTIC	
C6609	ECJ0EB1C103K	C CHIP 16V 0.01UF	

**COILS**

Ref. No.	Part No.	Part Name & Description	Remarks
L6503	G1C560MA0024	COIL COIL CHIP 56UH	

**PIN HEADERS**

Ref. No.	Part No.	Part Name & Description	Remarks
B6601	K1KB14AA0021	CONNECTOR 14P	
P6601	K1KA02B00292	CONNECTOR 2P	
P6602	K1KA02BA0047	CONNECTOR 2P	

**TRANSFORMER**

Ref. No.	Part No.	Part Name & Description	Remarks
T6601	G5D1A0000040	TRANSFORMER	

**13.2.3.3. SIDE R P.C.B.**

**BATTERY**

Ref. No.	Part No.	Part Name & Description	Remarks
BT6301	ML-614R/F9AT	BATTERY	

**TRANSISTORS**

Ref. No.	Part No.	Part Name & Description	Remarks
Q6301	2SB09700RL	TRANSISTOR SI PNP CHIP	

**DIODES**

Ref. No.	Part No.	Part Name & Description	Remarks
D6301	B3AAB0000038	LIGHT EMITTING DIODE	

**RESISTORS**

Ref. No.	Part No.	Part Name & Description	Remarks
R6301	ERJ2GEJ220X	MGF CHIP 1/16W 22	
R6302	ERJ2GEJ220X	MGF CHIP 1/16W 22	
R6303	ERJ2GEJ220X	MGF CHIP 1/16W 22	
R6304	ERJ2GEJ220X	MGF CHIP 1/16W 22	
R6305	ERJ2GEJ220X	MGF CHIP 1/16W 22	
R6306	DOGA103JA015	MGF CHIP 1/16W 10K	
R6307	DOGA103JA015	MGF CHIP 1/16W 10K	
R6308	DOGA103JA015	MGF CHIP 1/16W 10K	
R6309	DOGA103JA015	MGF CHIP 1/16W 10K	
R6310	DOGA103JA015	MGF CHIP 1/16W 10K	
R6316	ERJ3GEYJ223V	MGF CHIP 1/16W 22K	
R6317	ERJ3GEYJ223V	MGF CHIP 1/16W 22K	
R6318	ERJ6GEYJ512V	MGF CHIP 1/10W 5.1K	
R6322	DOGA333JA015	MGF CHIP 1/16W 33K	
R6323	ERJ2GEJ331X	MGF CHIP 1/16W 330	
R6324	ERJ2GEJ271X	MGF CHIP 1/16W 270	
R6325	ERJ6GEYJ150V	MGF CHIP 1/10W 15	

**CAPACITORS**

Ref. No.	Part No.	Part Name & Description	Remarks
C6301	F3F0J226A032	TANTALUM CHIP 6.3V 22UF	
C6302	ECJ0EB1A104K	C CHIP 10V 0.1UF	
C6303	ECJ0EB1A104K	C CHIP 10V 0.1UF	
C6304	ECJ0EC1H270J	C CHIP 50V 27PF	
C6305	ECJ0EC1H270J	C CHIP 50V 27PF	
C6306	ECJ0EC1H270J	C CHIP 50V 27PF	
C6307	ECJ0EC1H270J	C CHIP 50V 27PF	
C6308	ECJ0EC1H270J	C CHIP 50V 27PF	
C6309	FIG0J105A001	C CHIP 6.3V 1UF	
C6310	ECJ0EB1C103K	C CHIP 16V 0.01UF	
C6312	FIG1C103A004	C CHIP 16V 0.01UF	
C6313	FIG1C103A004	C CHIP 16V 0.01UF	
C6314	FIG1C103A004	C CHIP 16V 0.01UF	

**COILS**

Ref. No.	Part No.	Part Name & Description	Remarks
L6301	G1C100M00010	COIL CHIP 10UH	

**CONNECTORS**

Ref. No.	Part No.	Part Name & Description	Remarks
P6301	K1KA02BA0014	CONNECTOR 2P	
FP6301	K1MN22BA0197	CONNECTOR 22P	

**SWITCHES**

Ref. No.	Part No.	Part Name & Description	Remarks
SW6301	K0H1BA000436	SWITCH	
SW6302	K0H1BA000436	SWITCH	
SW6303	K0D113B00087	SWITCH SLIDE	

**JACK**

Ref. No.	Part No.	Part Name & Description	Remarks
U6301	K1NA09E00038	SD CARD HOLDER	

**13.2.3.4. FRONT P.C.B.**

**INTEGRATED CIRCUITS**

Ref. No.	Part No.	Part Name & Description	Remarks
IC4801	C0ABBB000369	IC, LINEAR	
or	C0ABBB000262	IC, LINEAR	
IC4801			
IC6501	C0GBF0000024	IC, LINEAR	
IC6502	L2ES00000014	MECHANICAL SENSOR	
IC6503	L2ES00000015	MECHANICAL SENSOR	
IC6504	C0DBZGZ00046	IC, LINEAR	

**TRANSISTORS**

Ref. No.	Part No.	Part Name & Description	Remarks
Q4801	2SD2216J08	TRANSISTOR SI NPN CHIP	
Q6501	2SD10300SL	TRANSISTOR SI NPN CHIP	
Q6502	2SD2216J08	TRANSISTOR SI NPN CHIP	
Q6503	UNR9213J08	TRANSISTOR SI NPN CHIP	
Q6504	UNR9213J08	TRANSISTOR SI NPN CHIP	
Q6505	UNR9115J08	TRANSISTOR SI PNP CHIP	
Q6506	B1BDBC000005	TRANSISTOR SI PNP CHIP	

**DIODES**

Ref. No.	Part No.	Part Name & Description	Remarks
D6503	MA3S132D0L	DIODE SI CHIP	
D6504	B3GA00000041	LIGHT EMITTING DIODE	
D6510	B3AAB0000146	LIGHT EMITTING DIODE	

**RESISTORS**

Ref. No.	Part No.	Part Name & Description	Remarks
R4802	DOGA472JA015	MGF CHIP 1/16W 4.7K	
R4803	DOGA223JA015	MGF CHIP 1/16W 22K	
R4804	DOGA333JA015	MGF CHIP 1/16W 33K	
R4805	ERJ2GEJ124X	MGF CHIP 1/16W 120K	
R4806	DOGA333JA015	MGF CHIP 1/16W 33K	
R4807	D0HA392ZA001	MGF CHIP 1/16W 3.9K	
R4808	ERJ2GEJ124X	MGF CHIP 1/16W 120K	
R4809	DOGA333JA015	MGF CHIP 1/16W 33K	
R4810	D0HA392ZA001	MGF CHIP 1/16W 3.9K	
R6501	ERJ2GEJ560X	MGF CHIP 1/16W 56	
R6502	DOGA683JA015	MGF CHIP 1/16W 68K	
R6503	ERJ2GEJ104X	MGF CHIP 1/16W 100K	
R6504	ERJ3GEYJ106V	MGF CHIP 1/16W 10M	
R6505	ERJ3GEYJ225V	MGF CHIP 1/16W 2.2M	
R6506	ERJ2GEJ334X	MGF CHIP 1/16W 330K	
R6507	DOGA182JA015	MGF CHIP 1/16W 1.8K	
R6508	DOGA472JA015	MGF CHIP 1/16W 4.7K	
R6509	ERJ2GE0R00X	MGF CHIP 1/16W 0	
R6510	ERJ2GEJ181X	MGF CHIP 1/16W 180	
R6511	ERJ2GEJ181X	MGF CHIP 1/16W 180	
R6530	ERJ2GEJ181X	MGF CHIP 1/16W 180	

## CAPACITORS

Ref. No.	Part No.	Part Name & Description	Remarks
C4801	F1G0J105A001	C CHIP 6.3V 1UF	
C4802	F1G0J105A001	C CHIP 6.3V 1UF	
C4803	ECJ2FB0J106K	C CHIP 6.3V 10UF	
C4804	ECJ0EB1C822K	C CHIP 16V 8200PF	
C4805	ECJ0EB1A273K	C CHIP 10V 0.027UF	
C4806	ECJ0EB1A273K	C CHIP 10V 0.027UF	
C4808	ECJ0EB1A273K	C CHIP 10V 0.027UF	
C4809	ECJ0EB1C822K	C CHIP 16V 8200PF	
C4810	ECJ0EB1A273K	C CHIP 10V 0.027UF	
C4812	F3F0J226A032	TANTALUM CHIP 6.3V 22UF	
C6502	ECJ2FB0J106K	C CHIP 6.3V 10UF	
C6503	F1H1A224A012	C CHIP 10V 0.22UF	
C6504	F1G1A1040006	C CHIP 10V 0.1UF	
C6505	F1H1A224A012	C CHIP 10V 0.22UF	
C6506	F3F0J226A032	TANTALUM CHIP 6.3V 22UF	
C6508	F3F0J226A032	TANTALUM CHIP 6.3V 22UF	
C6509	F3F0J226A032	TANTALUM CHIP 6.3V 22UF	
C6510	F3F0J226A032	TANTALUM CHIP 6.3V 22UF	
C6514	F1G1A1040006	C CHIP 10V 0.1UF	
C6515	F1G1A1040006	C CHIP 10V 0.1UF	
C6516	F3F0J106A032	TANTALUM CHIP 6.3V 10UF	
C6517	F3F0J226A032	TANTALUM CHIP 6.3V 22UF	

## COILS

Ref. No.	Part No.	Part Name & Description	Remarks
L6501	G1C100KA0031	COIL CHIP 10UH	
L6502	G1C100KA0031	COIL CHIP 10UH	

## CONNECTORS

Ref. No.	Part No.	Part Name & Description	Remarks
FP6501	K1MN20A00086	CONNECTOR 20P	
FP6502	K1MN10A00074	CONNECTOR 10P	

## MISCELLANEOUS

Ref. No.	Part No.	Part Name & Description	Remarks
U6501	B3RAB0000024	INFRARED RECEIVER	
	LSMG0136	MIC DAMPER	
	LSEK0695	MIC DEVICE UNIT	
	LSSC0852	MIC EARTH PLATE	

## 13.2.3.5. MONITOR P.C.B.

## TRANSISTORS

Ref. No.	Part No.	Part Name & Description	Remarks
Q901	2SA2174J0L	TRANSISTOR SI PNP CHIP	
Q902	2SC6054J0L	TRANSISTOR SI NPN CHIP	
Q903	2SC6054J0L	TRANSISTOR SI NPN CHIP	
Q904	2SC6054J0L	TRANSISTOR SI NPN CHIP	
Q905	2SA2174J0L	TRANSISTOR SI PNP CHIP	
Q906	2SC6054J0L	TRANSISTOR SI NPN CHIP	
Q907	2SC6054J0L	TRANSISTOR SI NPN CHIP	
Q908	2SC6054J0L	TRANSISTOR SI NPN CHIP	
Q913	2SA2174J0L	TRANSISTOR SI PNP CHIP	

## DIODES

Ref. No.	Part No.	Part Name & Description	Remarks
D901	MAZ80560ML	DIODE ZENER CHIP 5.6V	
D902	B0BC6R100025	DIODE ZENER CHIP 6.1V	
D905	B3AFB0000117	LIGHT EMITTING DIODE	
D906	B3AFB0000117	LIGHT EMITTING DIODE	
D907	B3AFB0000117	LIGHT EMITTING DIODE	
D908	B3AFB0000117	LIGHT EMITTING DIODE	
D909	B3AFB0000117	LIGHT EMITTING DIODE	
D910	B3AFB0000117	LIGHT EMITTING DIODE	

## RESISTORS

Ref. No.	Part No.	Part Name & Description	Remarks
R901	ERJ3GEY0R00V	MGF CHIP 1/16W 0	
R902	ERJ6GEY0R00V	MGF CHIP 1/10W 0	

Ref. No.	Part No.	Part Name & Description	Remarks
R906	ERJ3RBD563V	MGF CHIP 1/16W 56K	
R907	ERJ3RBD271V	MGF CHIP 1/16W 270	
R908	ERJ3RBD271V	MGF CHIP 1/16W 270	
R909	ERJ3RBD271V	MGF CHIP 1/16W 270	
R910	ERJ3RBD562V	MGF CHIP 1/16W 5600	
R915	ERJ3GEYJ102V	MGF CHIP 1/16W 1K	
R916	ERJ3GEY0R00V	MGF CHIP 1/16W 0	
R918	ERJ3RED270V	MGF CHIP 1/16W 27	
R924	ERJ3RED270V	MGF CHIP 1/16W 27	
R925	ERJ3RED270V	MGF CHIP 1/16W 27	
R926	ERJ3GEYJ104V	MGF CHIP 1/16W 100K	
R927	ERJ3GEY0R00V	MGF CHIP 1/16W 0	
R930	ERJ3RBD103V	MGF CHIP 1/16W 10K	
R931	ERJ3RED270V	MGF CHIP 1/16W 27	
R932	ERJ3RED270V	MGF CHIP 1/16W 27	
R933	ERJ3RED270V	MGF CHIP 1/16W 27	
R934	ERJ3GEY0R00V	MGF CHIP 1/16W 0	
R937	ERJ3RBD473V	MGF CHIP 1/16W 47K	
R940	ERJ3GEYJ103V	MGF CHIP 1/16W 10K	
R941	ERJ3GEYJ473V	MGF CHIP 1/16W 470	

## CAPACITORS

Ref. No.	Part No.	Part Name & Description	Remarks
C906	F1G1A1040006	C CHIP 10V 0.1UF	
C907	F1H1A105A036	C CHIP 10V 1UF	
C908	F1J1A2250007	C CHIP 10V 2.2UF	
C909	F1H1A105A036	C CHIP 10V 1UF	
C913	ECJ0EC1H390J	C CHIP 50V 39PF	
C914	ECJ0EC1H390J	C CHIP 50V 39PF	
C915	ECJ0EC1H390J	C CHIP 50V 39PF	
C918	F1J1A475A023	C CHIP 10V 4.7UF	
C933	F1H0J1050012	C CHIP 6.3V 1UF	

## COILS

Ref. No.	Part No.	Part Name & Description	Remarks
L901	G1C101KA0055	COIL CHIP 100UH	

## CONNECTORS

Ref. No.	Part No.	Part Name & Description	Remarks
FP902	K1MN23BA0132	CONNECTOR 23P	
FP903	K1MN24BA0055	CONNECTOR 24P	

## 13.2.3.6. EVF P.C.B.

## TRANSISTORS

Ref. No.	Part No.	Part Name & Description	Remarks
Q951	2SD2216JRL	TRANSISTOR SI NPN CHIP	

## DIODES

Ref. No.	Part No.	Part Name & Description	Remarks
D952	B3AFB0000127	LIGHT EMITTING DIODE	
D953	MAZ80560ML	DIODE ZENER CHIP 5.6V	

## RESISTORS

Ref. No.	Part No.	Part Name & Description	Remarks
R951	ERJ2GE0R00X	MGF CHIP 1/16W 0	
R952	ERJ2GE0R00X	MGF CHIP 1/16W 0	
R953	ERJ2RHD333X	MGF CHIP 1/16W 33K	
R954	ERJ2RHD103X	MGF CHIP 1/16W 10K	
R955	ERJ2RKD470X	MGF CHIP 1/16W 47	
R957	ERJ2GE0R00X	MGF CHIP 1/16W 0	
R958	DOGA152JA015	MGF CHIP 1/16W 1.5K	
R959	DOGA152JA015	MGF CHIP 1/16W 1.5K	
R960	ERJ2GEJ105X	MGF CHIP 1/16W 1M	

## CAPACITORS

Ref. No.	Part No.	Part Name & Description	Remarks
C951	F1H1A105A036	C CHIP 10V 1UF	
C952	F1H1A105A036	C CHIP 10V 1UF	

Ref. No.	Part No.	Part Name & Description	Remarks
C953	F1G1A1040006	C CHIP 10V 0.1UF	

## CONNECTORS

Ref. No.	Part No.	Part Name & Description	Remarks
FP951	K1MN18A00064	CONNECTOR 18P	
FP952	K1MN21BA0058	CONNECTOR 21P	